

LA-8041-MS

Informal Report

C2

**TMI-2 Decay Power:
LASL Fission-Product and Actinide Decay
Power Calculations for the President's
Commission on the Accident at Three Mile Island**

University of California



DO NOT CIRCULATE

PERMANENT RETENTION

REQUIRED BY CONTRACT



LOS ALAMOS SCIENTIFIC LABORATORY

Post Office Box 1663 Los Alamos, New Mexico 87545

An Affirmative Action/Equal Opportunity Employer

This report was not edited by the Technical Information staff.

This work was supported by the US Department of Energy, Office of Environmental Compliance and Overview.

This report was prepared as an account of work sponsored by the United States Government. Neither the United States nor the United States Department of Energy, nor any of their employees, nor any of their contractors, subcontractors, or their employees, makes any warranty, express or implied, or assumes any legal liability or responsibility for the accuracy, completeness, or usefulness of any information, apparatus, product, or process disclosed, or represents that its use would not infringe privately owned rights.

**UNITED STATES
DEPARTMENT OF ENERGY
CONTRACT W-7408-ENG. 36**

LA-8041-MS
Informal Report
UC-78
Issued: October 1979

**TMI-2 Decay Power:
LASL Fission-Product and Actinide Decay
Power Calculations for the President's
Commission on the Accident at Three Mile Island**

T. R. England
W. B. Wilson



TABLE OF CONTENTS

ABSTRACT	1
I. INTRODUCTION	1
II. CONTENT OF REPORT	1
III. DECAY SPECTRA	3
IV. COMMENT ON UNCERTAINTIES AND HEAT SOURCES	3
V. CALCULATIONAL BASES	5
A. CINDER and Auxiliary Codes and Libraries	5
B. ANS 5.1 Decay Power Standard	7
C. TMI-2 Reference Parameters	9
VI. TMI-2 POWER HISTORY	9
VII. TMI-2 DECAY POWER AND COMPARISONS	14
A. TMI-2 Heating and Curies	14
B. Comparisons With Equilibrium Core	14
C. Decay Power Fractions vs Irradiation Time	20
D. Comparisons of Generic Light Water Reactors	20
VIII. SUMMARY	25
ACKNOWLEDGMENTS	27
REFERENCES	27
APPENDIX A. THE 1978 ANS 5.1 DECAY POWER STANDARD FOR LIGHT WATER REACTORS: SUMMARY OF DATA USED IN THIS REPORT	29
APPENDIX B. TMI-2 CURIES, ATOMS, AND DECAY POWERS OF MAJOR FISSION- PRODUCT CONTRIBUTORS AND COMPARISON RESULTS FOLLOWING AN EXTENDED POWER PERIOD	38
APPENDIX C. TMI-2 NOBLE GAS AND HALOGENS AND COMPARISON RESULTS FOLLOWING A LONG IRRADIATION	108
APPENDIX D. TMI-2 FUEL DECAY POWER SURVEY	177
APPENDIX E. ACTINIDE DECAY POWER IN LWR SYSTEMS	191

LIST OF TABLES

TABLE		
I.	CINDER HISTOGRAM CORE POWER HISTORY THREE MILE ISLAND, UNIT 2 . . .	11
II.	TMI-2 FISSION RATES (AVERAGE VALUES PER TIME INTERVAL)	13
III.	CORE DECAY POWER -- THREE MILE ISLAND, UNIT 2	15
IV.	DECAY HEAT SOURCES IN TMI-2: TOTAL CORE VALUES IN MW VS COOLING TIME	18
V.	CURIES IN TMI-2: TOTAL CORE VALUES VS COOLING TIME	19
VI.	THREE MILE ISLAND UNIT 2 EQUILIBRIUM CORE ACTINIDE AND FISSION- PRODUCT DECAY POWER	21
VII.	COMPARISON OF CALCULATED DECAY POWER OF TMI-2 WITH END-OF-CYCLE EQUILIBRIUM CORE	22
VIII.	SUMMARY OF TMI-2 FUEL DECAY POWER SURVEY CALCULATIONS: FISSION- PRODUCT AND ACTINIDE DECAY POWER FOLLOWING CONTINUOUS IRRADIATIONS AT 33.8 kw/kg	26
A-I.	RATIO OF DECAY HEAT WITH ABSORPTION TO VALUES WITHOUT ABSORPTION.	31
A-II.	PARAMETERS FOR PULSE AND FINITE IRRADIATION DECAY-HEAT FUNCTIONS f(t) AND F(t,T)	33
A-III.	PARAMETERS FOR Δf , THE PULSE FUNCTION UNCERTAINTY	34
B-I through B-XXIV.	FOR TMI-2: TMI-2: CALCULATED VALUES OF IMPORTANT NUCLIDE CONTRIBUTIONS AT SHUTDOWN AND 23 COOLING TIMES	41
B-XXV through B-XLVIII.	FOR 26 000 HOURS AT 2772 MW: CALCULATED VALUES OF IMPORTANT NUCLIDE CONTRUBUTIONS AT SHUTDOWN AND 23 COOLING TIMES	73
C-I through C-XXIV.	FOR TMI-2: NOBLE GASES AND HALOGENS AT SHUTDOWN AND 23 COOLING TIMES	109
C-XXV through C-XXIX.	FOR TMI-2: CINDER-10 AGGREGATE SUMMARY TABLES	136
C-XXX through C-LIIII.	FOR 26 000 HOURS AT 2772 MW: NOBLE GASES AND HALOGENS AT SHUTDOWN AND 23 COOLING TIMES	141
C-LIV through C-LVIII.	FOR 26 000 HOURS AT 2772 MW: CINDER-10 AGGREGATE SUMMARY TABLES	170
D-I through D-XI.	TMI-2 FUEL DECAY POWER SURVEY: DECAY POWER FRACTION OF OPERATIONAL POWER FOLLOWING SUSTAINED POWER AT 33.8 kW/kg FOR 11 IRRADIATION TIMES	179

D-XII. CALCULATION OF RECOVERABLE ENERGY PER FISSION, Q	190
E-I. SUMMARY OF FUEL CASES STUDIED	193

LIST OF FIGURES

FIGURE

1	CINDER Histogram core power history, Three Mile Island, Unit 2 . . .	12
2	Total core decay power from actinides and fission products, Three Mile Island, Unit 2	16
3	Actinide and fission-product decay power components, Three Mile Island, Unit 2	17
4	Comparison of calculated decay power of TMI-2 with end-of-cycle equilibrium core	23
5	Total (fission-product plus actinide) decay power fraction of operational core power vs cooling time	24
A-1	ANS 5.1 Standard upper-bound absorption correction G_{max}	32
A-2	ANS 5.1 Standard fission-product decay power pulse functions . .	35
A-3	Ratio of ^{239}Pu and ^{238}U nominal decay heating to ^{235}U nominal - infinite irradiation	36
A-4	Comparison of Standard $F(t, \infty)$ for ^{235}U (1978) with 1973 Standard	37
B-1	Number of nuclides contributing $\geq 0.5\%$ of total actinide or fission-product decay power	40
C-1	TMI-2 gas fraction of total fission-product decay power	175
C-2	TMI-2 gas fractions of total fission-product density and curies.	176
E-1	Nuclide fission history, case 1A, PWR, 2.56% U235/U238 fuel, 34 GWD/MT, 1082 days	194
E-2	Fission-product decay power, case 1A, PWR, 2.56% U235/U238 fuel, 34 GWD/MT, 1082 days	195
E-3	Actinide nuclides important to decay power in U235/U238-fueled light water reactors	196
E-4	Nuclide contributors to actinide decay power, case 1A, PWR, 2.56% U235/U238 fuel, 34 GWD/MT, 1082 days	197
E-5	Fission-product and actinide decay power, case 1A, PWR, 2.56% U235/U238 fuel, 34 GWD/MT, 1082 days	198
E-6	Actinide fraction of total decay power, case 1A, PWR, 2.56% U235/U238 fuel, 34 GWD/MT, 1082 days	199

E-7	Nuclide contributors to actinide decay power, case 1C, PWR, 2.56% U235/U238 fuel, 2.765 GWD/MT, 88 days	200
E-8	Fission-product and actinide decay power, case 1C, PWR, 2.56% U235/U238 fuel, 2.765 GWD/MT, 88 days	201
E-9	Actinide fraction of total decay power, cases 1A, 1B, 1C, and 1D, PWR, 2.56% U235/U238 fuel, 0.1-34 GWD/MT	202
E-10	Nuclide contributors to actinide decay power, case 3 BWR, 2.95% U235/U238 fuel, 34 GWD/MT, 1909 days	203
E-11	Actinide fraction of total decay power, cases 1A, 2 and 3, low-enrichment U235/U238-fueled LWRs, 34 GWD/MT	204
E-12	Conceptual upper-bound actinide decay power correction factor for U235/U238-fueled LWRs	205
E-13	Actinide nuclides important to decay power in U233/Th232-fueled light water reactors	206
E-14	Nuclide contributors to actinide decay power, case 4, PWR, 2.95% U233/Th232 fuel, 34 GWD/MT, 835 days	207
E-15	Fission-product and actinide decay power, case 4, PWR, 2.95% U233/Th232 fuel, 34 GWD/MT, 835 days	208
E-16	Actinide fraction of total decay power, case 4, PWR, 2.95% U233/Th232 fuel, 34 GWD/MT, 835 days	209

TMI-2 DECAY POWER:
LASL FISSION-PRODUCT AND ACTINIDE DECAY POWER
CALCULATIONS FOR THE PRESIDENT'S COMMISSION
ON THE ACCIDENT AT THREE MILE ISLAND

by

T. R. England and W. B. Wilson

ABSTRACT

Fission-product and actinide decay heating, gas content, curies, and detailed contributions of the most important nuclide contributors were supplied in a series of letters following requests from the Presidential Commission on the Accident at Three Mile Island. In addition, similar data assuming different irradiation (power) histories were requested for purposes of comparison. This report consolidates the tabular and graphical data supplied and explains its basis.

I. INTRODUCTION

Requests for estimated data on decay heating and radioactivity at the Three Mile Island, Unit 2, (TMI-2) reactor following the incident on March 28, 1979 were received from the Presidential Commission on the TMI Accident. Such data can now be very accurately calculated once the detailed power history and other parameters specific to the reactor are known. The requested data were supplied in a series of letters, including comparison data for other power histories and reactor types.

This report consolidates the tabular and graphical data supplied to the Commission and describes the methods, codes, and libraries used.

II. CONTENT OF REPORT

The general content includes results for specific requests on aggregate decay heating and curies of the following nuclide groups.

- All fission products.
- All actinides.
- All fission products plus actinides.
- All noble gases (all isotopes of Kr and Xe).
- All halogens (all isotopes of Br and I).
- A specific set of nuclides consisting of all isotopes of the Br, I, Te, Ru, Cs, Ba, and Sr elements.

In addition to these aggregate groups, the heating, content, curies, etc., of the more important individual nuclides are listed in this report.

In all cases the beta, alpha and gamma components of the decay heating are also given.

All data are supplied at 23 or more cooling times between 1 s and 50 000 h (~5.7 y). Some survey data extend to 10^{13} s (~ 3.2×10^5 y), and the data for individual nuclides at the instant of reactor shutdown are also given.

For comparison purposes, similar data are listed for: a) an equilibrium fuel exposure at the full rated core power [2772 MW(t)]; b) detailed nuclide data subsequent to a long (26 000 h), constant power period, c) aggregate data for a series of irradiation times and cooling intervals between 1 and 10^{13} s, and d) comparisons of three generic light water reactors.

All of the results specific to TMI-2 are based on a detailed power history described in Sec. VI.

The main body of this report describes the TMI-2 power history, codes, methods, and the data base used in generating all final results and includes tabular and graphical values for the various aggregate results. Appendices include the detailed nuclide values of the largest contributors, noble gases, halogens, survey calculations for three generic reactor types, and other related data. In particular:

Appendix A contains information on the new (1978) ANS 5.1 Decay Power Standard. The standard was used where pertinent, as explained in a later section. Appendix A is therefore included for completeness and for the convenience of the reader.

Appendix B contains listings of individual contributors at each cooling time to the beta, gamma, beta + gamma (i.e., total fission-product) heating and curies for all fission products that contribute >0.5% to the total of any one of these four quantities. Densities are also listed. Values for TMI-2, and also for the same reactor assuming it had operated at a constant power for 26 000 hours prior to shutdown, are listed at the instant of shutdown and at 23 cooling intervals.

Appendix C contains listings of each significant noble gas and halogen for the same cases and cooling times in Appendix B. Except for general data preceeding and following each time step table, values are listed as fractions of all fission-product values (not fractional gas values). The individual radioactive gases are listed that contribute >0.01% of the beta, gamma, or beta + gamma contribution to the total gas values, but all values listed for aggregate gas summations include all gases. Here, the isotopes of Br and I are halogens and Kr and Xe are noble gases (>90 isotopes). Summary tables and graphs are included.

Appendix D contains aggregate actinide and fission-product decay heating for 11 constant irradiation (power) times and for cooling times between 1 s and 10^{13} s ($\sim 3.2 \times 10^5$ y). These data apply to a TMI-2 type of reactor operated for the assumed irradiation periods. Heating values are given as fractions of total core power prior to shutdown. Detailed considerations of the temporal parameters of actinide and fission-product decay power are also discussed.

Appendix E includes graphical comparisons from a recent study of three generic types of light water reactors (LWR's), including both actinide and fission-product data for different irradiation periods for the most common reactor type which is similar to TMI-2.

III. DECAY SPECTRA

With the assistance of R. J. LaBauve of LASL, twelve-group beta and gamma spectra from total, volatile and non-volatile fission products for use in NRC calculations of water radiolysis were calculated. These results were supplied to NRC, EPRI, and later to the Presidential Commission.

All calculations were based on an assumed 88 day constant power operation prior to shutdown, a simple history used before a more detailed knowledge of the actual time dependence was known, but one that is sufficient for use in calculations of spectra. (An accurate power history is described in a later section of this report.) These results are available¹ but were not specifically requested by the Commission and are not included in this report.

IV. COMMENT ON UNCERTAINTIES AND HEAT SOURCES

The aggregate (total) fission-product heating listed in the main body of this report has a 1 σ uncertainty of only 2 to 5%, depending on the cooling time. For cooling times $\lesssim 20$ hours this uncertainty is well supported by recent benchmark experiments and summation calculations. In fact, this uncertainty is probably conservative for the cooling range of $1-10^5$ s, important to a loss-of-coolant accident (LOCA). For longer cooling times

the small uncertainty still applies, but the heating rate is affected by neutron absorption in the fission products prior to shutdown; however, we believe we have accurately accounted for this effect specific to TMI-2.

There is no estimated uncertainty for actinide heating. This is believed to be very small at short cooling times, and is extremely unlikely to significantly affect the uncertainty in total (fission-product + actinide) heating for the cooling intervals specific to TMI-2 listed in this report. The TMI-2 power level prior to the incident would alter the initial total fission-product heating in direct proportion to the ratio of the actual fraction of rated power to the value (0.9739) used in this report for the final 20 days of operation. We have not included a power level uncertainty; as noted in a later section there is no reason to suspect the power level is significantly different from the value used in this report. (In this respect, the reader should note that the equilibrium case included for comparison was based on the full rated TMI-2 power; the fission-product heating from TMI-2 would be increased by ~2.7% had the reactor been operating at full power for a few hours prior to the incident.)

Uncertainties in individual nuclides depend on the quality of their specific data. This can be large for very short-lived nuclides but should be small for long-lived nuclides.

The heating data in this report assumes all nuclides are retained in the fuel and listed values of decay energy rates in MW apply to the total core. Where there is a breach in cladding the escape of volatile products will greatly decrease the heating rates. For example, between 1 s and 20 hours the noble gases and halogens together account for 22 to 28% of the total fission-product heating. Most of these products presumably escape in the absence of cladding. In addition other volatile products and the subsequent progeny of all gases and volatile nuclides escape.

All data in this report apply to products yielded in fission or to actinides initially present in the fuel or generated by neutron absorption in the fuel. There are other sources of heat. For example, during the first few cooling seconds, delayed neutrons will continue to cause fission and this will increase the initial heat rate. After ~ 20 seconds the fission products should dominate the heating, but we have not actually estimated the specific heating from delayed neutron fission for TMI-2. The $Zr-H_2O$ reaction is exothermic, and coolant pumping also supplies heat. There are

minor heat sources from structural material and impurities. Except for the Zr-H₂O reaction, which can occur in specific regions of the core, and the initial heating due to delayed neutrons, the heating rates in this report are the major heat sources during the first few hours of cooling and are the only significant heat sources once the coolant pumps are shutdown.

It is probable that decay heating can now be calculated as accurately as any reactor parameter, and more accurately than most parameters. This report benefits from intensive and extensive efforts begun in 1973 to improve and expand nuclide data in the Evaluated Nuclear Data Files ENDF/B-IV, supported by the U. S. Department of Energy (DOE), and from benchmark decay heat experiments at LASL, ORNL, IRT and UC(B), funded by the Nuclear Regulatory Commission (NRC) and the Electric Power Research Institute (EPRI). A concomitant effort to combine all data into a new ANS decay power standard was also initiated in 1975 and the result is also used in this report. Many people, including the authors, participated in these efforts. The specific use of these data are defined in more detail in the next section.

V. CALCULATIONAL BASES

A. CINDER and Auxiliary Codes and Libraries

The CINDER-10 (an improved version of CINDER-7²) and EPRI-CINDER³ fission-product and actinide buildup and depletion codes were used to generate most of the decay heating values and all related individual nuclide decay data in this report. These two codes are similar in basic types of output but differ in their range of applicability, in part, due to their nuclide data libraries. For completeness the essential differences are noted here, but the remainder of the text will simply refer to the CINDER Code except where a distinction is necessary.

CINDER-10: This is the latest version of CINDER and it utilizes a complete library of fission products-825 nuclides. This version is used for all calculations of individual fission-product contributions, noble gases, halogens, etc., and the results are applicable at all cooling times, including values at the instant of reactor shutdown. It could have been used for all fission product calculations in this report but its massive library is unnecessary at long cooling times. In addition, the extensive library of actinide data has not been put into a format suitable for CINDER-10.

EPRI-CINDER: This version contains a 47-nuclide actinide library and fission products suitable for long cooling times and absorption calculations. Those fission products having half-lives >4 hours and

those shorter lived nuclides in transient equilibrium with long lived parents are included. The library is suitable for fission-product decay heat calculations for cooling times > 20 hours. In addition, exposure-dependent, self-shielded cross sections are used in this version - important for long-lived reactors. CINDER-10 and EPRI-CINDER fission-product decay heating agree within ~1% for decay times > 20 hours. This version was used for all actinide calculations, and for some of the aggregate fission-product decay heating for cooling times > 20 hours. The information on β and γ heating at shorter times, all data on individual fission products at all times and other aggregate groupings were calculated using CINDER-10.

Libraries for both codes are derived from processed ENDF/B-IV⁴⁻⁶ data for the fission products,* and from preliminary ENDF/B-V for the actinides except, as noted below, for actinide data derived from EPRI-CELL.⁷

Actinide data for ~3 nuclides (not included in ENDF/B-V) were obtained from other sources. The cross sections used are in four neutron energy groups.

TOAFEW CODE⁸: 154 multigroup cross sections, obtained using the NJOY⁹ processing code, are included in the TOAFEW library. This code collapses the multigroup cross sections to the four group values used in CINDER using a typical LWR spectrum. All fission-product cross sections and cross sections of those actinides not obtained from EPRI-CELL were obtained using TOAFEW.

EPRI-CELL Code⁷: This proprietary code was used to obtain time-dependent self-shielded cross sections for ²³⁴U, ²³⁵U, ²³⁶U, ²³⁸U, ²³⁹Pu, ²⁴¹Pu, and ²⁴¹Am. It was also used to obtain ratios of the first three energy group fluxes to the thermal flux. The values were based on existing EPRI-CELL calculations for a PWR fuel that is neutronicly very similar to that of TMI-2.

The validity of summation code calculations using ENDF/B-IV data is extensively discussed in Refs. 10 and 11; both reports contain extensive references to recent research on decay heat.

Additional required input to CINDER is the TMI-2 power history and initial fuel content. The power history is discussed in Sec. VI. The initial content of fuel is based on the specifications in the TMI-2 FSAR (Final Safety

* Only the branching ratio of ¹³³I to ^{133m}Xe deviates from the summary data in Ref. 5 - from ENDF/B-IV. A more recent evaluation of this important parameter indicates it should be ~3% and this change has been reported to provide good agreement with measured ¹³³Xe content in the TMI-2 coolant water.

Analysis Report).

B. ANS 5.1 Decay Power Standard¹²

An extensive effort to produce a new decay heat standard for light water reactors was initiated in 1975 and essentially completed in its technical content 1978. At this time (August 1979) the standard has not yet been widely distributed; for completeness the primary data is included in Appendix A.

The new standard is based on a joint LASL and HEDL analysis that combines several recent benchmark experiments and calculations, as described in Refs. 10 and 11. Reference 13 also describes the new standard and its past history. In general for times $<10^5$ s the standard is a combination of calculations using the ENDF/B data in Ref. 4 and experiments for ^{235}U and ^{239}Pu . The results of all of the experiments are of high quality, obtained since 1975 at LASL, ORNL, IRT, UC(B) and in France (F-A-R). For longer times, and at all times for ^{238}U , the standard results entirely from CINDER-10 code calculations using ENDF/B-IV data. The analysis combines all data into an equivalent pulse function which was chosen to be a linear sum of exponentials,

$$f(t) = \sum_{i=1}^{23} \alpha_i e^{-\lambda_i t} \quad \text{MeV/Fiss-s} \quad . \quad (1)$$

This can be folded into any power history that can be, e.g., represented as a series of histograms. For example, for a single fuel at a constant fission rate for a time T seconds, the energy release rate at cooling time t seconds, normalized to the fission rate is

$$F(t,T) = \sum_{i=1}^{23} \frac{\alpha_i}{\lambda_i} e^{-\lambda_i t} (1 - e^{-\lambda_i T}) \quad \text{MeV/Fiss} \quad . \quad (2)$$

Similar expressions can be used for determining the uncertainties.

In an operating reactor there is a mixture of fuels that vary with time and generally a variable power history. For this, Eq. 1 is, essentially,

multiplied by the fission rate for each fuel and integrated to produce the heating in the units of MeV/s; the latter units are readily converted to, e.g., MW. The α , λ coefficients for each fuel are listed in Appendix A.

Pulse functions do not account for neutron absorption. This is a function of each specific reactor design and its power history. For cooling times $<10^4$ s the absorption effect is small - typically, the heating increase is ~1%, and is at most upwards of ~6% (for long irradiation times at $<10^4$ s of cooling). For longer cooling times the effect can be very large. The new standard incorporates an empirical expression for absorption based on burnup for times $t <10^4$ s and an upper bound value based on CINDER-10 calculations for longer times (the upper bound can also be used as an option at all times). The upper bound value is derived from two CINDER-10 calculations with and without absorption for an unrealistically long irradiation time and high flux level.

It is important to note that calculations for TMI-2 and other comparison cases in this report do not use the upper bound absorption correction, except where indicated in the tables, and then only for times <20 hours. The absorption effect is implicit in the CINDER-10 output at all cooling times; some calculations using the standard do use the upper bound correction in some cases, as specifically noted in the tables, and only for cooling times <20 hours where the correction is small.

For aggregate fission-product heating at times $t <20$ hours, the new standard should be superior to calculations using CINDER or any other summation code. We have therefore used the standard for the aggregate heating during this interval where possible. For this, a code, DKPOWR,¹⁴ incorporating the pulse functions is used. Fission rates vs time from each fuel, as calculated by CINDER, are necessary input for the DKPOWR code.

For accuracy at longer cooling times, and for all cooling times requiring individual nuclide contributions, α , β , and γ heating components and special sets of nuclides such as noble gases or actinides, it is necessary to use the results of CINDER calculations. Most of the results in this report are therefore calculated using CINDER and the data libraries described previously, but the new standard is used where possible and where it would improve the accuracy of gross fission-product heating.

C. TMI-2 Reference Parameters

The following miscellaneous parameters were obtained or derived from the FSAR of TMI-2. These are included for completeness; only the derived initial fuel atoms from these data and rated thermal power are important to this report.

RATED POWER (MWt) = 2772.

AVERAGE ENRICHMENT (Wt % of ^{235}U) = 2.57.

FUEL WEIGHT OF UO_2 (lbs) = 204,820.

TOTAL MASS OF U (Kg) = 82057.2.

FULL POWER DENSITY (KW/Kg) = 33.8.

SPECIFIC RATED POWER (W/cm^3) = 280.75.

GROSS POWER RATING (MWe) = 961.

NET DESIGN RATING (MWe) = 906.

The neutron spectrum used in collapsing the 154 multigroup cross sections to four groups for the fission products is described in Refs. 3 and 8, which also lists the cross sections. Cross sections of the actinides are not listed. The dominate actinides have exposure-dependent cross sections as described previously; the remainder were derived using the same spectrum as for the fission products.

Another parameter required by CINDER is the average recoverable energy per fission. This value varies with fissioning nuclides from 202.64 MeV (^{235}U) to 213.44 MeV (^{241}Pu) for thermal reactor spectra. Values for several fissionable nuclides at thermal, fast and 14 MeV fission energies are listed in Table D-XII of Appendix D. For TMI-2, the average value used in CINDER was 3.261181×10^{-11} joules, or 203.56 MeV. This parameter, along with actinide densities, specified TMI-2 power levels and the flux ratios derived from EPRI-CELL calculations determine the four-group neutron flux levels and hence the fuel depletion and fission rates in the core. (For reference the average ratio of the resonance region group flux to the thermal values is ~1.48. This applies over the range of 0.625 - 5530 eV. The higher energy fluxes are not as significant as the thermal and resonance region values.)

VI. TMI-2 POWER HISTORY

The monthly Metropolitan Edison reports to the Nuclear Regulatory Commission (NRC) were used to obtain an accurate approximation to the detailed TMI-2 power history. For use in calculating decay heating an important

aspect of this history is the nearly constant power during the final 20 days prior to the incident on March 28, 1979; the gross electrical output shows a daily variation of no more than ~1.3% during this period. The thermal energy produced is ~20.4% of the total. In addition, most (~52.5%) of the total thermal energy [~ 6400231 MWh(t)] was produced between February 1 and March 28 with only a brief shutdown period on March 6. The earlier power history is highly variable. Precise levels cannot be determined from the limited detail of the monthly reports, but precision in the earlier time variation of the history is not needed for accurate calculations; rather, it is important to reproduce the total thermal energy, particularly for actinide buildup calculations. While only the net electrical power is reported daily, the needed thermal energy is reported by month. For this report we have used the daily electrical power to proportion and preserve the accumulated monthly value.

The resulting power history is described in Table I and Fig. 1. It is unlikely that any two people would infer precisely the same history from the monthly reports. For calculations in this report, and probably for any other study, this history is certainly adequate. Based on the rated thermal power of 2772 MW, the effective full power days of operation for this history is 96.2. (Some earlier LASL studies used 88 days, and the authors have seen some correspondence using ~52 and ~94 days.)

The fission rates by fuel type calculated with the CINDER code for this power history are listed in Table II; these are required for aggregate fission-product heating calculations with the DKPOWR Code, using the ANS 5.1 pulse functions, as previously described.

The reader should note that during the final 20 days of operation, ^{239}Pu accounts for ~10% of the core power (fission rate) and ~6.6% over the short life of TMI-2. For longer lifetimes the ^{239}Pu fractional contribution to core power continues to increase, as does that from ^{241}Pu . The importance of this observation is apparent from Fig. A-3 in Appendix A: the heating from ^{239}Pu fission products is significantly smaller than that from ^{235}U at short cooling times important to LOCA. Therefore, other factors aside, the early decay heat rates would decrease for longer lived reactors. This will be apparent in the survey calculations for different irradiation times noted in Sec. VII and Appendix D of this report.

TABLE I

CINDER HISTOGRAM CORE POWER HISTORY
THREE MILE ISLAND, UNIT 2

<u>Period</u>	<u>Start Time/date</u>	<u>End Time/date</u>	<u>Δt (h)</u>	<u>Elapsed Time (h)</u>	<u>Ave. Power Mw(th)</u>
1	0300/4-21-78	1700/4-23-78	62.0	62.0	611.6
2	1700/4-23-78	2030/9-17-78	3531.5	3593.5	0.0
3	2030/9-17-78	2400/9-30-78	315.5	3909.0	524.52
4	0000/10-1-78	1400/10-5-78	110.0	4019.0	1109.0
5	1400/10-5-78	2400/10-12-78	178.0	4197.0	0.0
6	0000/10-13-78	0500/10-28-78	365.0	4562.0	1488.94
7	0500/10-28-78	1400/11-1-78	105.0	4667.0	0.0
8	1400/11-1-78	2400/11-3-78	58.0	4725.0	2397.8
9	0000/11-4-78	0230/11-5-78	26.5	4751.5	0.0
10	0230/11-5-78	0530/11-7-78	51.0	4802.5	2034.1
11	0530/11-7-78	1800/12-3-78	636.5	5439.0	0.0
12	1800/12-3-78	0200/12-16-78	296.0	5735.0	2104.09
13	0200/12-16-78	0700/12-22-78	149.0	5884.0	0.0
14	0700/12-22-78	2400/12-31-78	233.0	6117.0	2467.3
15	0000/1-1-79	0800/1-14-79	320.0	6437.0	2281.8
16	0800/1-14-79	1440/1-31-79	414.67	6851.67	0.0
17	1440/1-31-79	2400/1-31-79	9.33	6861.0	33.4
18	0000/2-1-79	2400/2-28-79	672.0	7533.0	2462.14
19	0000/3-1-79	1545/3-6-79	135.75	7668.75	2743.5
20	1545/3-6-79	0815/3-7-79	16.5	7685.25	0.0
21	0815/3-7-79	2400/3-7-79	15.75	7701.0	1697.6
22	0000/3-8-79	0400/3-28-79	484.0	8185.0	2699.704

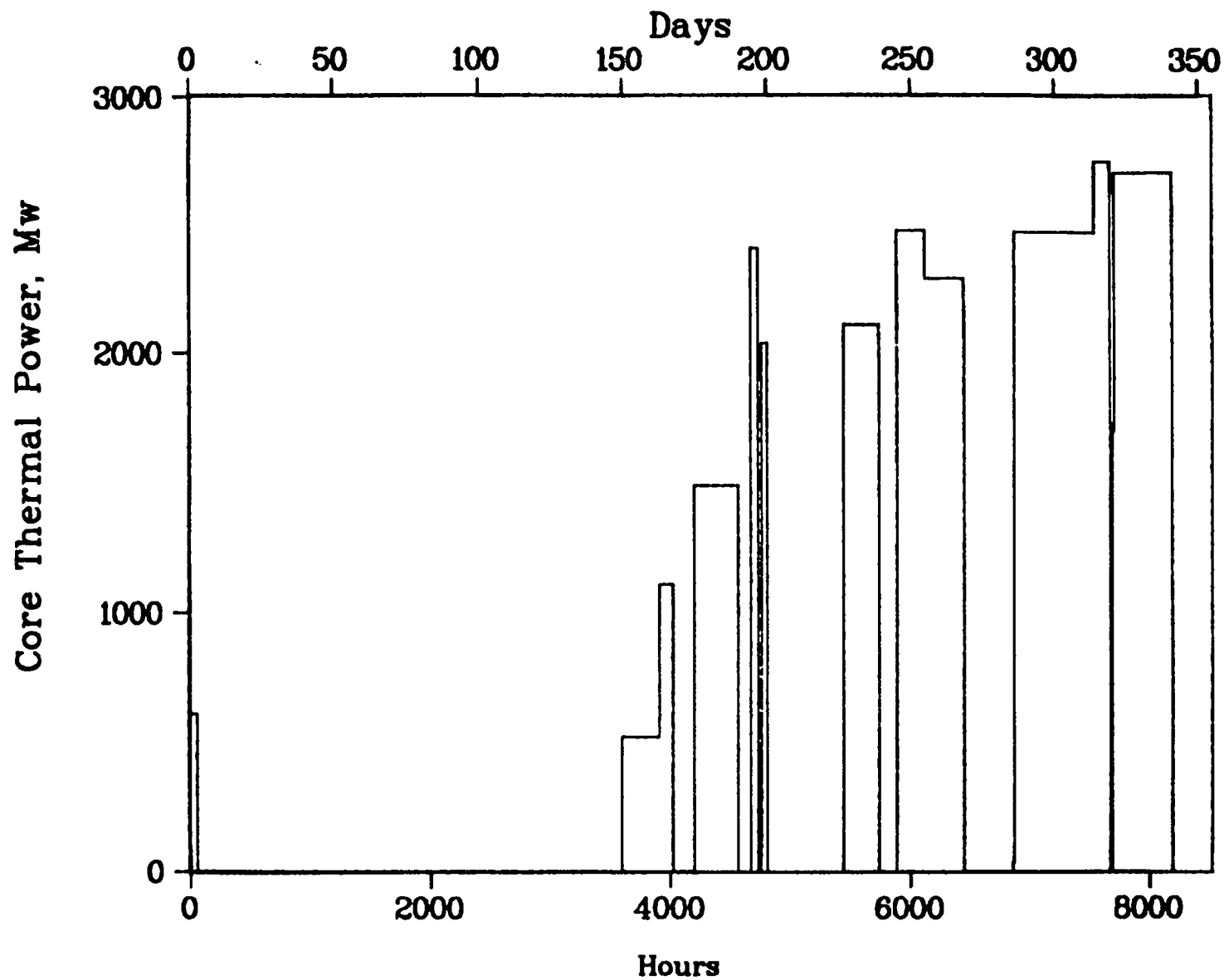

Fig. 1. CINDER Histogram core power history,
Three Mile Island, Unit 2.

TABLE II
TMI-2 FISSION RATES
(AVERAGE VALUES PER TIME INTERVAL)^a

TIME STEP	TIME INTERVAL HOURS	²³⁵ U	²³⁸ U	FISSION/s ²³⁹ Pu	²⁴¹ U	TOTAL
1	62.0	1.77+19 ^b	1.14+18	2.77+15	7.81+8	1.884+19
2	3531.5	0	0	0	0	0
3	315.5	1.51+19	9.65+17	4.14+6	4.16+11	1.608+19
4	110.0	3.18+19	1.98+18	1.77+17	4.59+12	3.400+19
5	178.0	0	0	0	0	0
6	365.0	4.24+19	2.66+18	6.02+17	1.06+14	4.56+19
7	105.0	0	0	0	0	0
8	58.0	6.76+19	4.27+18	1.55+18	4.15+14	7.347+19
9	26.5	0	0	0	0	0
10	51.0	5.72+19	3.67+18	1.45+18	5.04+14	6.236+19
11	636.5	0	0	0	0	0
12	296.0	5.86+19	3.78+18	2.06+18	1.44+15	6.44+19
13	149.0	0	0	0	0	0
14	233.0	6.77+19	4.43+18	3.38+18	4.48+15	7.556+19
15	320.0	6.19+19	4.10+18	3.97+18	9.38+15	7.003+19
16	414.67	0	0	0	0	0
17	9.33	8.94+17	5.97+16	7.04+16	1.88+14	1.024+18
18	672.0	6.47+19	4.52+18	6.15+18	3.03+16	7.540+19
19	135.75	7.07+19	5.05+18	8.29+18	5.86+16	8.412+19
20	165.0	0	0	0	0	0
21	15.75	4.35+19	3.12+18	5.36+18	4.04+16	5.206+19
22	484.0	6.83+19	4.96+18	9.43+18	9.28+16	8.274+19

^aValues apply to the total core.

^bRead 1.77+19 as 1.77×10^{19} .

NOTE: Accumulated fissions are

$$^{235}\text{U} = 6.1714 + 26$$

$$^{238}\text{U} = 4.1879 + 25$$

$$^{239}\text{Pu} = 4.6787 + 25$$

$$^{241}\text{Pu} = 2.8248 + 23$$

$$\text{SUM} = 7.06087 + 26$$

VII. TMI-2 DECAY POWER AND COMPARISONS

In this section the tabular and graphical decay power data on aggregate results supplied to the Commission are listed, including comparison data for the equilibrium core and graphical comparisons of a series of requested calculations for 11 irradiation times.

The results for each important nuclide, noble gas and halogen, other information as previously described, and component tabular data for the 11 irradiation times are included in appendices.

All data for curies and decay heating in MW are average total core values. All TMI-2 results are based on the power history in Table I and Fig. 1.

A. TMI-2 Heating and Curies

TABLE III lists the decay power in MW from fission products and actinides, including the beta, gamma and alpha components (there is no significant alpha component from the fission products).

Figure 2 Total core decay power from actinides plus fission products is plotted.

Figure 3 Total decay power from the actinides and fission products are compared. (Appendix E shows similar comparisons for three long lived generic reactors and Addendix D lists tabular values for TMI-2 if operated for eleven irradiation times - a graphical and tabular comparison of total values is included further on in this section.

TABLE IV This is similar to Table III for decay power except noble gases, halogens and a special set of nuclides are also listed. The special group of nuclides, specifically requested by the Commission Staff, consists of all isotopes of Br, I, Te, Ru, Cs, Ba, and Sr. (Gaseous data are plotted in Appendix C.)

TABLE V lists the total curies in all fission products, noble gases, halogens and the special set of nuclides noted above along with actinide curies and curies in the total core.

B. Comparisons With Equilibrium Core

The equilibrium core calculation traces the actinide and fission-product decay power in each of three species of reactor fuel following shutdown at the end of an equilibrium core period. The equilibrium core is assumed to

TABLE III

CORE DECAY POWER -- THREE MILE ISLAND, UNIT 2

Cooling Time	Fission-Product Decay Power, MW ^b			Actinide Decay Power, MW ^c				Total Decay Power, MW			
	Beta	Gamma	Total	Alpha	Beta	Gamma	Total	Alpha	Beta	Gamma	Total
1.00+0 s ^a	8.21+1	7.88+1	1.61+2	3.54-4	5.05+0	1.78+0	6.83+0	3.54-4	8.71+1	8.06+1	1.68+2
4.00+0 s	7.05+1	7.05+1	1.41+2	3.54-4	5.04+0	1.78+0	6.82+0	3.54-4	7.56+1	7.23+1	1.48+2
1.00+1 s	6.05+1	6.29+1	1.23+2	3.54-4	5.04+0	1.78+0	6.81+0	3.54-4	6.55+1	6.47+1	1.30+2
4.00+1 s	4.52+1	5.10+1	9.62+1	3.54-4	4.99+0	1.77+0	6.76+0	3.54-4	5.02+1	5.27+1	1.03+2
1.00+2 s	3.65+1	4.28+1	7.93+1	3.54-4	4.90+0	1.76+0	6.66+0	3.54-4	4.14+1	4.46+1	8.60+1
4.00+2 s	2.65+1	3.24+1	5.90+1	3.54-4	4.48+0	1.70+0	6.19+0	3.54-4	3.10+1	3.41+1	6.52+1
1.00+3 s	2.09+1	2.65+1	4.74+1	3.54-4	3.82+0	1.61+0	5.43+0	3.54-4	2.47+1	2.81+1	5.28+1
1.00+0 h	1.40+1	1.78+1	3.17+1	3.55-4	2.41+0	1.42+0	3.83+0	3.55-4	1.64+1	1.92+1	3.56+1
2.00+0 h	1.10+1	1.40+1	2.51+1	3.55-4	1.94+0	1.35+0	3.29+0	3.55-4	1.30+1	1.54+1	2.84+1
5.00+0 h	8.26+0	1.01+1	1.84+1	3.55-4	1.78+0	1.29+0	3.07+0	3.55-4	1.00+1	1.14+1	2.14+1
1.00+1 h	6.37+0	8.11+0	1.45+1	3.56-4	1.68+0	1.21+0	2.89+0	3.56-4	8.05+0	9.32+0	1.74+1
2.00+1 h	4.87+0	6.45+0	1.13+1	3.58-4	1.48+0	1.07+0	2.56+0	3.58-4	6.35+0	7.52+0	1.39+1
5.00+1 h	2.73+0	4.43+0	7.15+0	3.61-4	1.03+0	7.43-1	1.77+0	3.61-4	3.76+0	5.17+0	8.93+0
1.00+2 h	2.13+0	3.50+0	5.63+0	3.64-4	5.60-1	4.04-1	9.65-1	3.64-4	2.69+0	3.90+0	6.59+0
2.00+2 h	1.65+0	2.61+0	4.26+0	3.66-4	1.67-1	1.21-1	2.88-1	3.66-4	1.82+0	2.73+0	4.55+0
5.00+2 h	1.08+0	1.50+0	2.58+0	3.66-4	5.46-3	4.11-3	9.94-3	3.66-4	1.09+0	1.50+0	2.59+0
1.00+3 h	7.07-1	8.54-1	1.56+0	3.64-4	1.75-4	1.45-4	6.84-4	3.64-4	7.08-1	8.54-1	1.56+0
2.00+3 h	4.28-1	4.55-1	8.83-1	3.61-4	6.92-6	2.01-6	3.69-4	3.61-4	4.28-1	4.55-1	8.83-1
5.00+3 h	1.89-1	1.34-1	3.22-1	3.55-4	4.60-6	1.03-7	3.60-4	3.55-4	1.89-1	1.34-1	3.23-1
1.00+0 y	1.06-1	3.33-2	1.40-1	3.52-4	4.52-6	1.17-7	3.57-4	3.52-4	1.06-1	3.33-2	1.40-1
1.00+4 h	9.22-2	2.27-2	1.15-1	3.52-4	4.49-6	1.21-7	3.57-4	3.52-4	9.22-2	2.27-2	1.15-1
2.00+4 h	3.73-2	5.85-3	4.32-2	3.56-4	4.29-6	1.60-7	3.60-4	3.56-4	3.73-2	5.85-3	4.35-2
5.00+4 h	7.66-3	3.23-3	1.09-2	3.75-4	3.76-6	2.66-7	3.80-4	3.75-4	7.66-3	3.23-3	1.13-2

^a Read as 1.00×10^0 seconds.

^b Fission-product total decay power values were calculated with the DKPOWR code for cooling times $t \leq 20$ h, using the fission pulse functions and upper-bound absorption correction Gmax of the recent ANS Standard 5.1, "Decay Heat Power in Light Water Reactors." The beta and gamma components of fission-product decay power were obtained using beta and gamma decay power fractions calculated with CINDER-10 (for $t \leq 20$ h) and EPRI-CINDER (for $t > 20$ h). All fission-product decay power quantities for $t > 20$ h were calculated with EPRI-CINDER.

^c Actinide alpha, beta, gamma, and total decay power values are from tandem EPRI-CELL/EPRI-CINDER calculations.

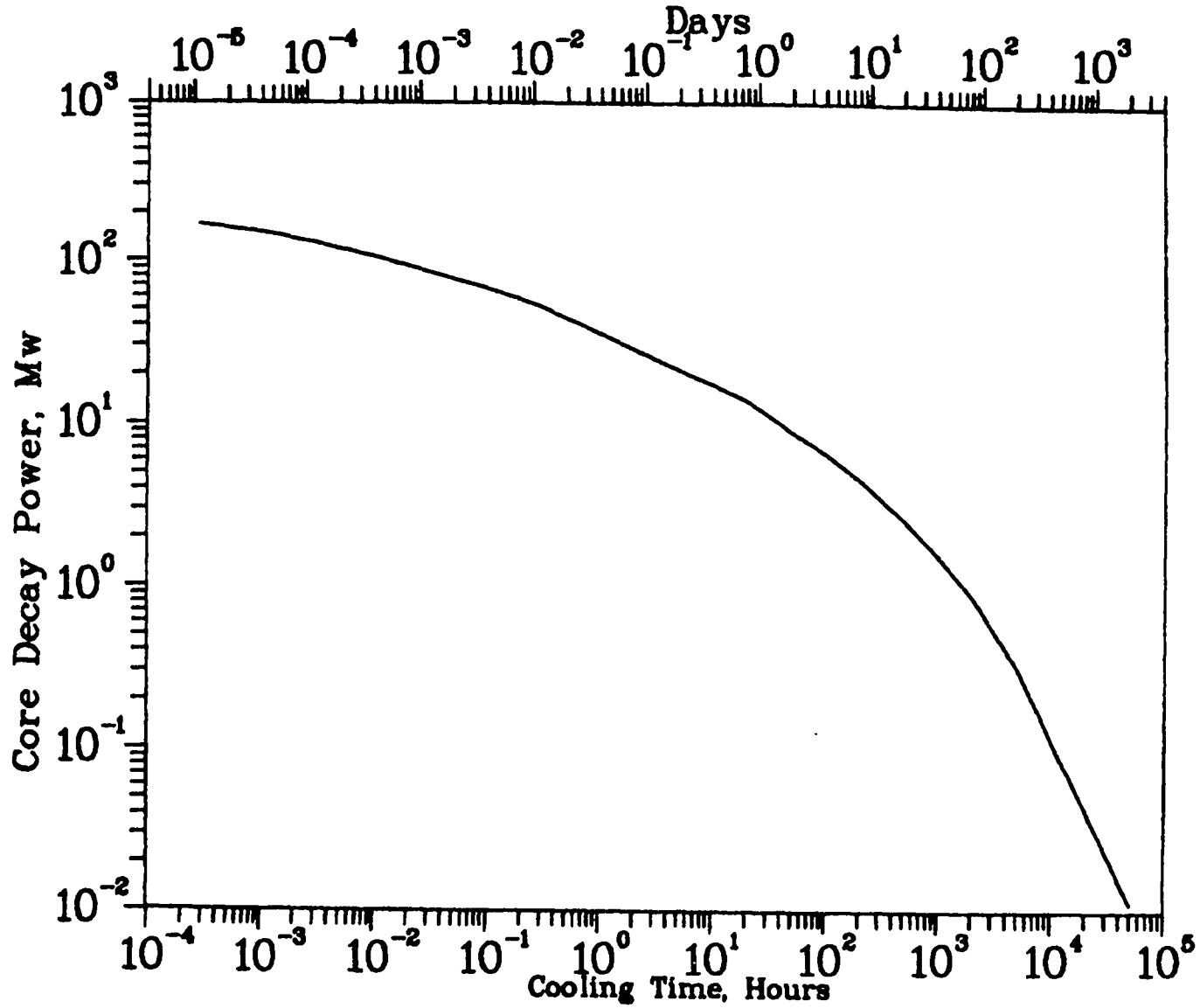

Fig. 2. Total core decay power from actinides and fission products, Three Mile Island, Unit 2.

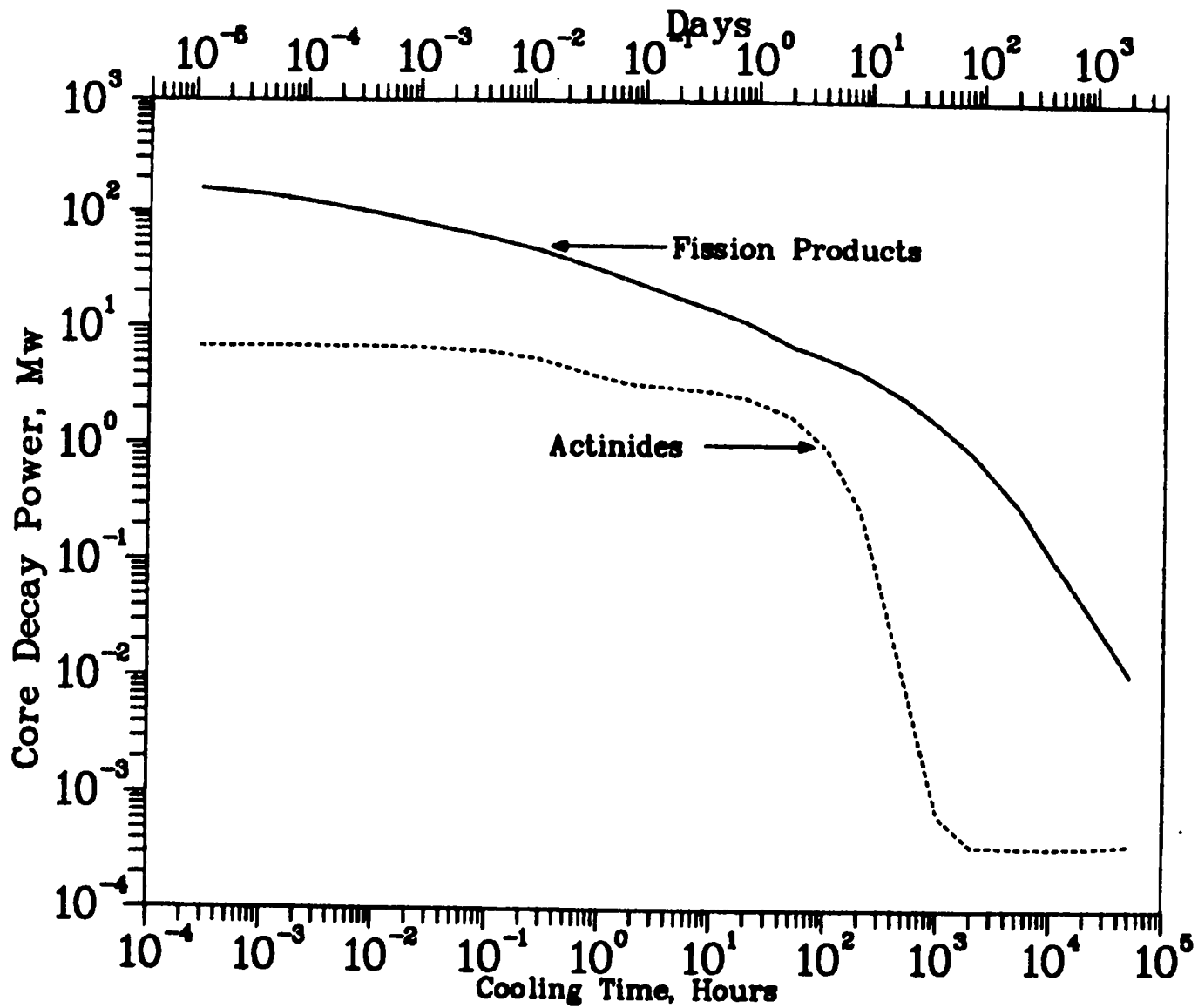

Fig. 3. Actinide and fission-product decay power components, Three Mile Island, Unit 2.

TABLE IV
 DECAY HEAT SOURCES IN TMI-2
 TOTAL CORE VALUES IN MW VS COOLING TIME^a
 LASL - 7/79

COOLING TIME	NOBLE GAS (Kr + Xe)	HALOGENS (I + Br)	NOBLE GAS + HALOGENS	SPECIAL ^b SET	ALL FISSION PRODUCTS	ACTINIDES	ACTINIDES + FISSION PRODUCTS
1.00 + 0 s	1.39 + 1 ^c	1.88 + 1	3.27 + 1	5.53 + 1	1.61 + 2	6.83 + 0	1.68 + 2
4.00 + 0 s	1.25 + 1	1.70 + 1	2.95 + 1	5.03 + 1	1.41 + 2	6.82 + 0	1.48 + 2
1.00 + 1 s	1.12 + 1	1.52 + 1	2.64 + 1	4.55 + 1	1.23 + 2	6.81 + 0	1.30 + 2
4.00 + 1 s	8.49 + 0	1.20 + 1	2.05 + 1	3.63 + 1	9.62 + 1	6.76 + 0	1.03 + 2
1.00 + 2 s	6.59 + 0	9.82 + 0	1.64 + 1	2.99 + 1	7.93 + 1	6.66 + 0	8.60 + 1
4.00 + 2 s	4.11 + 0	8.02 + 0	1.21 + 1	2.32 + 1	5.90 + 1	6.19 + 0	6.52 + 1
1.00 + 3 s	2.78 + 0	7.69 + 0	1.05 + 1	1.97 + 1	4.74 + 1	5.48 + 0	5.28 + 1
1.00 + 0 h	1.71 + 0	6.65 + 0	8.37 + 0	1.36 + 1	3.17 + 1	3.83 + 0	3.56 + 1
2.00 + 0 h	1.30 + 0	5.42 + 0	6.72 + 0	1.01 + 1	2.51 + 1	3.29 + 0	2.84 + 1
5.00 + 0 h	7.85 - 1	3.70 + 0	4.48 + 0	6.68 + 0	1.84 + 1	3.07 + 0	2.14 + 1
1.00 + 1 h	5.01 - 1	2.94 + 0	3.44 + 0	5.23 + 0	1.45 + 1	2.89 + 0	1.74 + 1
2.00 + 1 h	3.32 - 1	2.25 + 0	2.59 + 0	4.03 + 0	1.13 + 1	2.56 + 0	1.39 + 1
5.00 + 1 h	1.75 - 1	1.43 + 0	1.60 + 0	2.71 + 0	7.15 + 0	1.77 + 0	8.93 + 0
1.00 + 2 h	1.18 - 1	8.66 - 1	9.85 - 1	1.88 + 0	5.63 + 0	9.65 - 1	6.59 + 0
2.00 + 2 h	6.85 - 2	3.89 - 1	4.57 - 1	1.19 + 0	4.26 + 0	2.88 - 1	4.55 + 0
5.00 + 2 h	1.35 - 2	5.66 - 2	7.01 - 2	6.01 - 1	2.58 + 0	9.94 - 3	2.59 + 0
1.00 + 3 h	1.08 - 3	6.40 - 3	7.48 - 3	3.48 - 1	1.56 + 0	6.84 - 4	1.56 + 0
2.00 + 3 h	1.55 - 4	1.70 - 4	3.25 - 4	1.66 - 1	8.83 - 1	3.69 - 4	8.83 - 1
5.00 + 3 h	1.40 - 4	3.83 - 9	1.40 - 4	3.66 - 2	3.22 - 1	3.60 - 4	3.23 - 1
1.00 + 0 y	1.36 - 4	1.38 - 10	1.36 - 4	1.48 - 2	1.40 - 1	3.57 - 4	1.40 - 1
1.00 + 4 h	1.35 - 4	~ 0	1.35 - 4	1.29 - 2	1.15 - 1	3.57 - 4	1.15 - 1
2.00 + 4 h	1.25 - 4	~ 0	1.25 - 4	7.63 - 3	4.32 - 2	3.60 - 4	4.35 - 2
5.00 + 4 h	1.00 - 4	~ 0	1.00 - 4	4.74 - 3	1.09 - 2	3.80 - 4	1.13 - 2

^aThe last three columns were included in Table III provides the α , β , and γ components for these three columns.

^bSpecial set includes all halogens (Br and I) plus requested Te, Ru, Cs, Ba, and Sr nuclides.

^cRead 1.39 + 1 as $1.39 \times 10^{+1}$, etc.

NOTE ON METHOD OF DATA GENERATION:

1. Actinide heating computed with EPRI-CINDER code.
2. Fission product heating uses pulse functions from new ANS 5.1 decay heat standard up to 20 hours, including corrections for absorption using CINDER-10. EPRI-CINDER used for longer times to get accurate effect of absorption on heating (CINDER-10 and EPRI-CINDER agree within ~1%).
3. Noble gas, halogens and special set columns generated by CINDER-10.

NOTE: See Appendix C for graphical plots of gas fractions and detailed contributions of each noble gas and halogen.

TABLE V
 CURIES IN TMI-2
 TOTAL CORE VALUES VS COOLING TIME^a
 [CINDER CALCULATIONS (LASL)]
 7/79

COOLING SEC	TIME HOURS	ALL FISSION PRODUCTS	NOBLE GAS (Kr + Xe)	SPECIAL SET ^b	HALOGENS (Br + I)	ACTINIDES	TOTAL ACTINIDES + FP
1	2.78 - 4 ^c	1.19 + 10	1.14 + 9	4.42 + 9	1.11 + 9	2.61 + 9	1.45 + 10
4	1.11 - 3	1.11 + 10	1.06 + 9	4.18 + 9	1.05 + 9	2.61 + 9	1.36 + 10
1.0 + 1	2.78 - 3	1.03 + 10	9.87 + 8	3.94 + 9	1.00 + 9	2.60 + 9	1.29 + 10
4.0 + 1	1.11 - 2	8.80 + 9	8.23 + 8	3.44 + 9	8.49 + 8	2.58 + 9	1.14 + 10
1.0 + 2	2.78 - 2	7.78 + 9	7.03 + 8	3.08 + 9	7.54 + 8	2.55 + 9	1.03 + 10
4.0 + 2	1.11 - 1	6.40 + 9	5.34 + 8	2.61 + 9	6.63 + 8	2.38 + 9	8.78 + 9
1.0 + 3	2.78 - 1	5.52 + 9	4.33 + 8	2.28 + 9	6.39 + 8	2.11 + 9	7.63 + 9
3.6 + 3	1.0	4.25 + 9	3.44 + 8	1.75 + 9	5.77 + 8	1.52 + 9	5.77 + 9
7.2 + 3	2.0	3.69 + 9	3.11 + 8	1.46 + 9	5.03 + 8	1.32 + 9	5.01 + 9
1.8 + 4	5.0	3.06 + 9	2.68 + 8	1.15 + 9	3.87 + 8	1.24 + 9	4.30 + 9
3.6 + 4	10.0	2.59 + 9	2.36 + 8	9.83 + 8	3.16 + 8	1.17 + 9	3.76 + 9
7.2 + 4	20.0	2.13 + 9	2.00 + 8	8.25 + 8	2.42 + 8	1.03 + 9	3.16 + 9
1.8 + 5	50.0	1.60 + 9	1.44 + 8	6.28 + 8	1.49 + 8	7.18 + 8	2.32 + 9
3.6 + 5	100.0	1.26 + 9	1.08 + 8	4.94 + 8	9.27 + 8	3.91 + 8	1.65 + 9
7.2 + 5	200.0	9.57 + 8	6.28 + 7	3.75 + 8	4.93 + 7	1.18 + 8	1.08 + 9
1.8 + 6	500.0	6.07 + 8	1.24 + 7	2.39 + 8	1.21 + 7	4.37 + 6	6.11 + 8
3.6 + 6	1000.0	3.95 + 8	9.66 + 5	1.50 + 8	1.83 + 6	3.22 + 5	3.95 + 8
7.2 + 6	2000.0	2.30 + 8	1.07 + 5	7.86 + 7	4.99 + 4	1.54 + 5	2.30 + 8
1.8 + 7	5000.0	7.94 + 7	9.32 + 4	2.59 + 7	1.24 + 0	1.49 + 5	7.95 + 7
3.1536 + 7	8760.0 (1 yr)	3.55 + 7	9.06 + 4	1.45 + 7	1.92 - 1	1.47 + 5	3.56 + 7
3.6 + 7	10000.0	2.98 + 7	8.98 + 4	1.29 + 7	1.92 - 1	1.46 + 5	2.99 + 7
7.2 + 7	20000.0	1.26 + 7	8.34 + 4	6.18 + 6	1.92 - 1	1.39 + 5	1.27 + 7
1.8 + 8	50000.0	4.10 + 6	6.69 + 4	2.41 + 6	1.92 - 1	1.20 + 5	4.22 + 7

^aCINDER-10 calculations for fission products, EPRI-CINDER for actinides.

^bSpecial set includes all halogens (Br and I) plus requested Te, Ru, Cs, Ba, and Sr nuclides.

^cRead 2.78 - 4 as 2.78 x 10⁻⁴, etc.

NOTE: See Appendix C for graphical plots of gas fractions and detailed contributions of each noble gas and halogen.

consist of equal fuel volumes of 2.96 Wt% ^{235}U reload fuel irradiated for one, two, and three years. Specifically, the three regions consist of

- 1/3 of the core irradiated for the last 330 days prior to shutdown,
- 1/3 irradiated for 330 days, shutdown for 35 days, and then irradiation for the final 330 days,
- 1/3 of the core having two 330 day irradiation and 35 day shutdown periods prior to the final 330 day irradiation.

The core was assumed to operate at the full thermal power of 2772 MW for the equilibrium calculations. The specific core power density was maintained at 33.8 KW/Kg (based on original loading) during the powered intervals. The equilibrium-core discharge fuel thus has an exposure of 33.462 GWD/t.

TABLE VI shows the actinide, fission product and total heating for each fuel cycle and the total core values.

TABLE VII shows the comparisons to TMI-II with the total equilibrium core. Figure 4 shows the graphical comparison of the total core data in Table VII.

The reader may prefer to normalize the TMI-2 and equilibrium core values to their respective power levels of 2699.7 and 2722 MW. In this case the decay fraction of the power prior to shutdown for the equilibrium core is smaller than that of TMI-2 for the first 100 s of cooling; the absolute value without normalization is the smaller for the first 40 s. The primary reason for this behavior is smaller heating from ^{239}Pu products than from ^{235}U , discussed in an earlier section and in Appendix A.

C. Decay Power Fractions vs Irradiation Time

Appendix D contains detailed tabular data for fission-product and actinide heating for 11 constant irradiation (power) periods and cooling times between 1 and 10^{13} s ($\sim 3.2 \times 10^5$ y). All results are based on a full TMI-2 core power of 2772 MW, and details are noted in the Appendix.

Table VIII and Fig. 5 show a graphical comparison of all total core heating cases normalized to the total core power prior to shutdown. It is interesting that the one-month irradiation shows an initial net value exceeding all other cases. (It also exceeds the initial TMI-2 fractional value.)

D. Comparisons of Generic Light Water Reactors

Appendix E shows graphical comparisons for three types of light water reactors. One is similar to TMI-2 and is included with more than one

TABLE VI

THREE MILE ISLAND UNIT 2 EQUILIBRIUM CORE
ACTINIDE AND FISSION-PRODUCT DECAY POWER

Cooling Time	ONE-CYCLE FUEL			TWO-CYCLE FUEL			THREE-CYCLE FUEL			TOTAL CORE FUEL		
	Act. (MW)	F.P. (MW)	Total (MW)	Act. (MW)	F.P. (MW)	Total (MW)	Act. (MW)	F.P. (MW)	Total (MW)	Act. (MW)	F.P. (MW)	Total (MW)
1.00+0 s ^a	2.41+0 ^b	5.34+1 ^c	5.58+1	2.67+0 ^b	5.13+1 ^c	5.40+1	3.03+0 ^b	5.01+1 ^c	5.31+1	8.11+0	1.55+2	1.63+2
4.00+0 s	2.41+0	4.70+1	4.94+1	2.67+0	4.52+1	4.79+1	3.03+0	4.42+1	4.72+1	8.11+0	1.36+2	1.45+2
1.00+1 s	2.41+0	4.13+1	4.37+1	2.66+0	3.98+1	4.25+1	3.02+0	3.90+1	4.20+1	8.09+0	1.20+2	1.28+2
4.00+1 s	2.39+0	3.25+1	3.49+1	2.64+0	3.15+1	3.41+1	3.00+0	3.09+1	3.39+1	8.03+0	9.49+1	1.03+2
1.00+2 s	2.35+0	2.70+1	2.94+1	2.60+0	2.62+1	2.88+1	2.96+0	2.58+1	2.88+1	7.91+0	7.90+1	8.70+1
4.00+2 s	2.19+0	2.03+1	2.25+1	2.42+0	1.98+1	2.22+1	2.76+0	1.95+1	2.23+1	7.37+0	5.96+1	6.70+1
1.00+3 s	1.92+0	1.64+1	1.83+1	2.14+0	1.60+1	1.81+1	2.44+0	1.58+1	1.82+1	6.50+0	4.82+1	5.46+1
1.00+0 h	1.36+0	1.11+1	1.25+1	1.53+0	1.08+1	1.23+1	1.76+0	1.07+1	1.25+1	4.65+0	3.26+1	3.73+1
2.00+0 h	1.17+0	8.91+0	1.01+1	1.32+0	8.73+0	1.01+1	1.53+0	8.61+0	1.01+1	4.02+0	2.63+1	3.03+1
5.00+0 h	1.10+0	6.74+0	7.84+0	1.23+0	6.65+0	7.88+0	1.43+0	6.60+0	8.03+0	3.76+0	2.00+1	2.38+1
1.00+1 h	1.03+0	5.48+0	6.51+0	1.16+0	5.47+0	6.63+0	1.34+0	5.45+0	6.79+0	3.53+0	1.64+1	1.99+1
2.00+1 h	9.13-1	4.45+0	5.36+0	1.03+0	4.48+0	5.51+0	1.19+0	4.48+0	5.67+0	3.13+0	1.34+1	1.65+1
5.00+1 h	6.36-1	3.01+0	3.64+0	7.22-1	3.10+0	3.82+0	8.47-1	3.19+0	4.04+0	2.21+0	9.30+0	1.15+1
1.00+2 h	3.49-1	2.46+0	2.81+0	4.05-1	2.56+0	2.96+0	4.90-1	2.64+0	3.13+0	1.24+0	7.66+0	8.90+0
2.00+2 h	1.08-1	1.96+0	2.07+0	1.38-1	2.05+0	2.19+0	1.89-1	2.13+0	2.31+0	4.35-1	6.14+0	6.57+0
5.00+2 h	6.53-3	1.32+0	1.33+0	2.32-2	1.41+0	1.44+0	5.67-2	1.48+0	1.54+0	8.64-2	4.22+0	4.31+0
1.00+3 h	1.98-3	8.96-1	8.98-1	1.60-2	9.94-1	1.01+0	4.57-2	1.06+0	1.11+0	6.37-2	2.95+0	3.02+0
2.00+3 h	1.53-3	5.69-1	5.70-1	1.34-2	6.68-1	6.82-1	3.87-2	7.38-1	7.77-1	5.36-2	1.98+0	2.03+0
5.00+3 h	9.60-4	2.46-1	2.47-1	8.64-3	3.36-1	3.45-1	2.50-2	4.05-1	4.30-1	3.46-2	9.87-1	1.02+0
1.00+0 y	8.48-4	1.28-1	1.29-1	5.40-3	2.00-1	2.06-1	1.55-2	2.58-1	2.74-1	2.17-2	5.86-1	6.09-1
1.00+4 h	7.94-4	1.10-1	1.10-1	4.73-3	1.77-1	1.81-1	1.36-2	2.31-1	2.45-1	1.91-2	5.17-1	5.36-1
2.00+4 h	6.34-4	4.63-2	4.69-2	2.53-3	8.25-2	8.51-2	6.97-3	1.15-1	1.22-1	1.01-2	2.44-1	2.54-1
5.00+4 h	7.06-4	1.25-2	1.32-2	2.36-3	2.50-2	2.73-2	5.82-3	3.73-2	4.31-2	8.89-3	7.48-2	8.36-2

^aRead as 1.00×10^0 seconds.

^bActinide decay power values are from tandem EPRI-CELL/EPRI-CINDER calculations.

^cFission-product total decay power values were calculated with the DKPOWER code for cooling times $t \leq 20$ h, using the fission pulse functions and upper-bound absorption correction G_{max} of the recent ANS Standard 5.1, "Decay Heat Power in Light Water Reactors." The beta and gamma components of fission-product decay power were obtained using beta and gamma decay power fractions calculated with CINDER-10 (for $t \leq 20$ h) and EPRI-CINDER (for $t > 20$ h). All fission-product decay power quantities for $t > 20$ h were calculated with EPRI-CINDER.

TABLE VII
 COMPARISON OF CALCULATED DECAY POWER OF
 TMI-2 WITH END-OF-CYCLE EQUILIBRIUM CORE

<u>Cooling Time</u>	<u>Total Core Decay Power, MW</u>	
	<u>TMI-2</u>	<u>Eq. Core</u>
1.00+0 s ^a	1.68+2	1.63+2
4.00+0 s	1.48+2	1.45+2
1.00+1 s	1.30+2	1.28+2
4.00+1 s	1.03+2	1.03+2
1.00+2 s	8.60+1	8.70+1
4.00+2 s	6.52+1	6.70+1
1.00+3 s	5.28+1	5.46+1
1.00+0 h	3.56+1	3.73+1
2.00+0 h	2.84+1	3.03+1
5.00+0 h	2.14+1	2.38+1
1.00+1 h	1.74+1	1.99+1
2.00+1 h	1.39+1	1.65+1
5.00+1 h	8.93+0	1.15+1
1.00+2 h	6.59+0	8.90+0
2.00+2 h	4.55+0	6.57+0
5.00+2 h	2.59+0	4.31+0
1.00+3 h	1.56+0	3.02+0
2.00+3 h	8.83-1	2.03+0
5.00+3 h	3.23-1	1.02+0
1.00+0 y	1.40-1	6.09-1
1.00+4 h	1.15-1	5.36-1
2.00+4 h	4.35-2	2.54-1
5.00+4 h	1.13-2	8.36-2

^aRead as 1.00x10⁰ seconds.

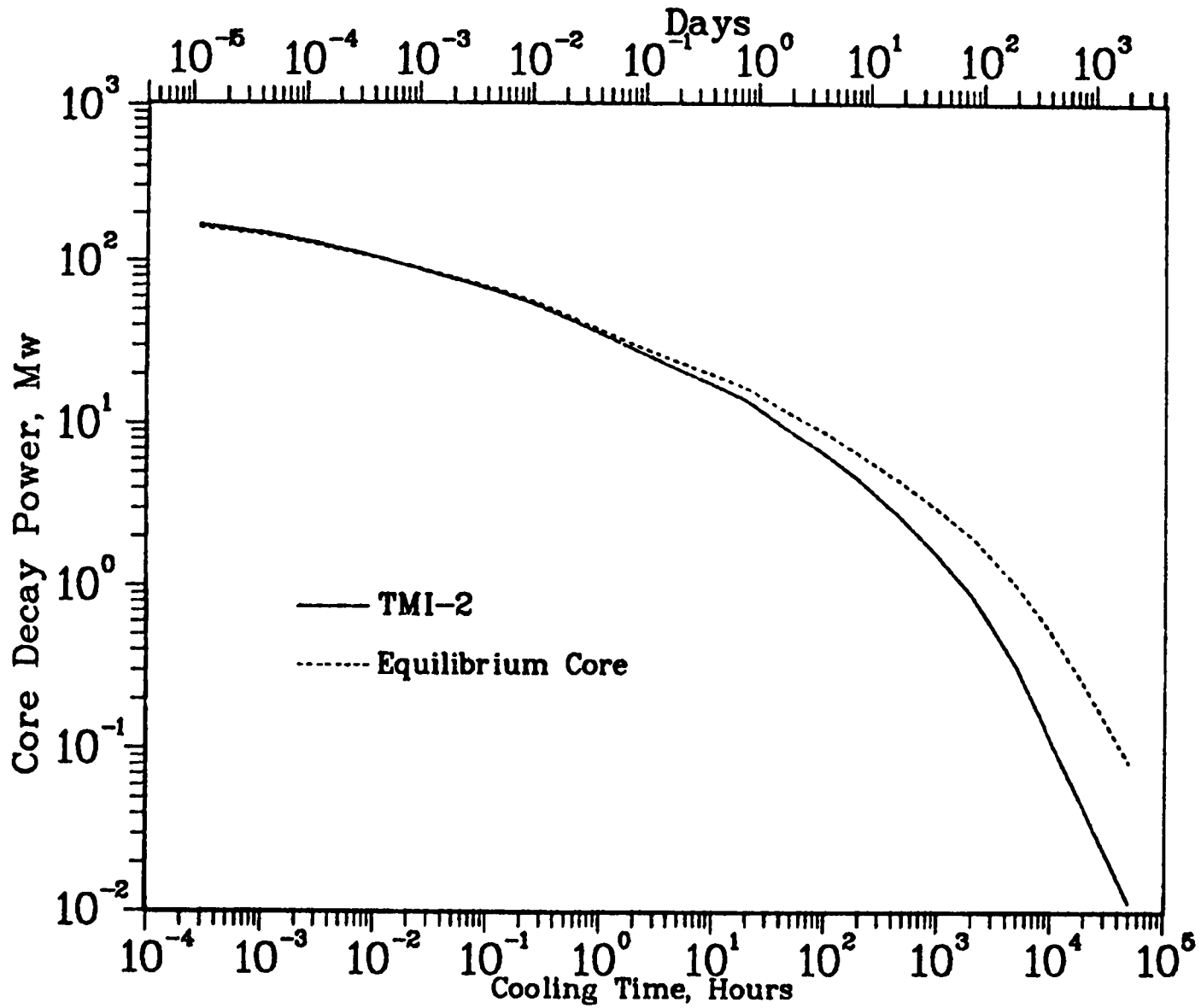

Fig. 4. Comparison of calculated decay power of TMI-2 with end-of-cycle equilibrium core.

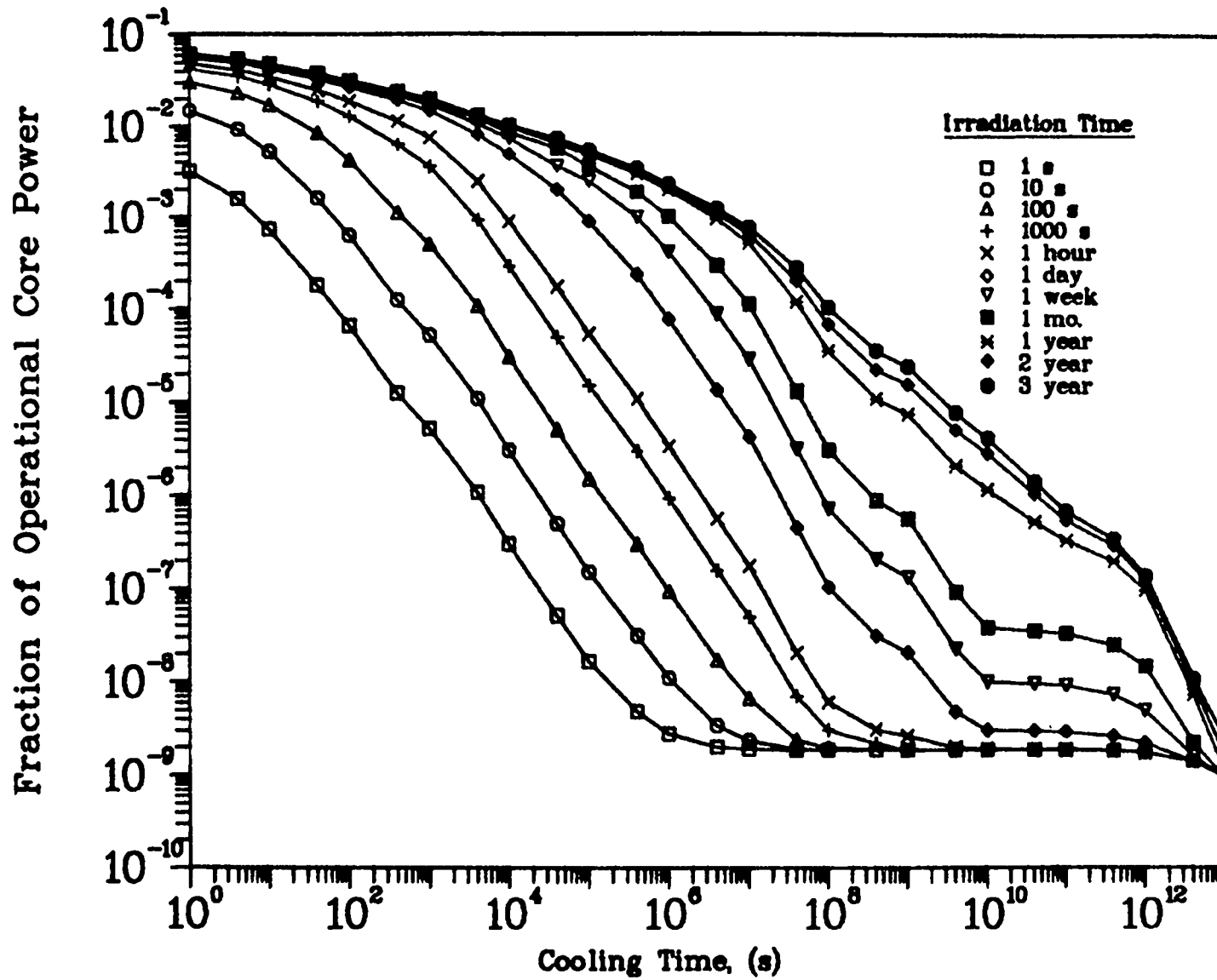

Fig. 5. Total (fission-product plus actinide) decay power fraction of operational core power vs cooling time.

irradiation period. This appendix, based on earlier data prepared for Ref. 15 is included for general interest and for the detailed plots of actinide content. However, the fission-product heating uses the upper bound correction for absorption in fission products given in the ANS 5.1 Standard. As noted in a prior section, this correction is likely much too large at some cooling times. Therefore, results in this Appendix should only be intercompared except for the actinide heating.

VIII. SUMMARY

The previous section provides best estimates of the total core decay power and curies for TMI-2, and comparison decay powers for the equilibrium core and a survey of values for a wide range of irradiation and cooling times. The decay data used have been widely tested and the four group cross sections and fluxes should closely match the values in TMI-2. The very recent ANS 5.1 decay power standard has been used where possible and where it is believed to be more accurate than calculations using the EPRI-CINDER summation code. This is only possible for total fission-product heating, and for this it is less accurate than the summation calculations for times >20 hours of cooling.

The α , β , and γ components of heating, actinide heating, and all other values for specific nuclide groups necessarily resort to the summation code calculations.

All values apply to the total core assuming all nuclides are retained in the fuel; some of the heating for nuclide groups, particularly for the noble gases and halogens, indicate that there can be a very significant decrease in heating rates once the fuel cladding is breached, as apparently happened in part of the TMI-2 fuel.

As is clear from comparisons with the equilibrium core case and the graphical data in Fig. 5, the decay heating rates are larger during the first few cooling seconds following relatively short irradiation times of fresh fuel than for long irradiation periods, a result of the relatively small ²³⁹Pu content in fresh fuel.

Appendices B and C contain detailed nuclide results for the larger contributors to fission product heating components and curies and also the detailed content of noble gases and halogens. Comparison results for a

TABLE VIII
SUMMARY OF TMI-2 FUEL DECAY POWER SURVEY CALCULATIONS
FISSION-PRODUCT AND ACTINIDE DECAY POWER
FOLLOWING CONTINUOUS IRRADIATIONS AT 33.8 kw/kg.

Cooling Time(s)	Total Decay Power Fraction of Operational Power										
	Irradiation Period Length										
	1-s	10-s	100-s	1000-s	1-hour	1-day	1-week	1-mo.	1-year	2-year	3-year
1.00+00	3.18-03	1.49-02	3.08-02	4.31-02	4.94-02	5.78-02	6.03-02	6.26-02	6.02-02	5.85-02	5.71-02
4.00+00	1.57-03	9.25-03	2.35-02	3.56-02	4.19-02	5.03-02	5.28-02	5.50-02	5.34-02	5.20-02	5.08-02
1.00+01	7.20-04	5.19-03	1.71-02	2.89-02	3.52-02	4.36-02	4.61-02	4.83-02	4.72-02	4.62-02	4.53-02
4.00+01	1.76-04	1.58-03	8.45-03	1.89-02	2.51-02	3.34-02	3.59-02	3.79-02	3.77-02	3.71-02	3.66-02
1.00+02	6.48-05	6.15-04	4.19-03	1.28-02	1.88-02	2.71-02	2.96-02	3.15-02	3.17-02	3.14-02	3.10-02
4.00+02	1.23-05	1.21-04	1.09-03	6.29-03	1.14-02	1.93-02	2.19-02	2.37-02	2.43-02	2.42-02	2.40-02
1.00+03	5.10-06	5.08-05	4.87-04	3.55-03	7.40-03	1.48-02	1.73-02	1.91-02	1.98-02	1.98-02	1.97-02
4.00+03	1.07-06	1.06-05	1.05-04	9.10-04	2.41-03	8.01-03	1.05-02	1.22-02	1.31-02	1.31-02	1.31-02
1.00+04	2.99-07	2.97-06	2.95-05	2.78-04	8.66-04	4.84-03	7.25-03	8.49-03	9.96-03	1.00-02	1.01-02
4.00+04	5.10-08	4.93-07	4.91-06	4.84-05	1.68-04	1.96-03	3.60-03	5.63-03	6.38-03	7.08-03	7.21-03
1.00+05	1.66-08	1.49-07	1.47-06	1.46-05	5.20-05	8.68-04	2.43-03	3.56-03	4.80-03	5.07-03	5.32-03
4.00+05	4.83-09	3.14-08	2.97-07	2.95-06	1.06-05	2.27-04	9.74-04	1.83-03	2.94-03	3.14-03	3.31-03
1.00+06	2.79-09	1.10-08	9.35-08	9.18-07	3.29-06	7.48-05	3.99-04	9.77-04	1.94-03	2.09-03	2.22-03
4.00+06	2.03-09	3.42-09	1.73-08	1.56-07	5.58-07	1.32-05	8.48-05	2.82-04	9.30-04	1.07-03	1.19-03
1.00+07	1.92-09	2.36-09	6.68-09	5.00-08	1.75-07	4.13-06	2.80-05	1.08-04	4.95-04	6.28-04	7.43-04
4.00+07	1.88-09	1.93-09	2.39-09	7.04-09	2.05-08	4.47-07	3.09-06	1.28-05	1.15-04	1.95-04	2.68-04
1.00+08	1.88-09	1.89-09	1.99-09	3.05-09	6.12-09	1.04-07	7.12-07	3.03-06	3.43-05	6.64-05	1.00-04
4.00+08	1.88-09	1.88-09	1.91-09	2.21-09	3.09-09	3.10-08	2.05-07	8.72-07	1.07-05	2.18-05	3.45-05
1.00+09	1.88-09	1.88-09	1.90-09	1.84-09	2.65-09	2.05-08	1.32-07	5.59-07	7.31-06	1.52-05	2.35-05
4.00+09	1.87-09	1.87-09	1.88-09	1.91-09	2.00-09	4.81-09	2.24-08	9.12-08	2.07-06	5.01-06	7.64-06
1.00+10	1.87-09	1.87-09	1.88-09	1.89-09	1.92-09	3.03-09	9.91-09	3.76-08	1.15-06	2.82-06	4.09-06
4.00+10	1.87-09	1.87-09	1.87-09	1.88-09	1.92-09	2.98-09	9.54-09	3.51-08	5.23-07	1.05-06	1.40-06
1.00+11	1.86-09	1.86-09	1.86-09	1.87-09	1.91-09	2.91-09	9.12-09	3.29-08	3.30-07	5.44-07	6.80-07
4.00+11	1.82-09	1.82-09	1.82-09	1.83-09	1.85-09	2.62-09	7.31-09	2.47-08	1.99-07	2.93-07	3.44-07
1.00+12	1.74-09	1.74-09	1.74-09	1.75-09	1.76-09	2.20-09	4.91-09	1.47-08	9.63-08	1.27-07	1.38-07
4.00+12	1.40-09	1.40-09	1.40-09	1.40-09	1.40-09	1.43-09	1.60-09	2.23-09	7.25-09	9.41-09	1.08-08
1.00+13	9.40-10	9.40-10	9.40-10	9.40-10	9.40-10	9.40-10	9.41-10	9.45-10	1.09-09	1.61-09	2.47-09

constant power of 2772.0 MW for 26 000 hours are included. These data are necessarily based entirely on summation code results.

All data in this report, with the exception of the supporting information on the ANS 5.1 Standard in Appendix A and the generic reactor comparisons in Appendix E were specifically requested by the Presidential Commission. All non-redundant data supplied to the Commission to date (August 16, 1979) that are based on an accurate power history, except for the decay spectra, are included.

ACKNOWLEDGMENTS

We appreciate the support and expeditious effort of Dr. W. R. Stratton, currently serving as a member of the Commission's Staff, in procuring the TMI-2 parameters needed for this report. Dr. Stratton and Prof. Thomas H. Pigford, a member of the Commission, together defined the specific data needs and its most useful form. Additional specifications of the required data were received from Dr. Robert English, a member of the Commission's Staff. We especially appreciate the technical assistance of Mrs. N. L. Whittemore; the information and graphical plots in this report could not have been completed on schedule without her assistance. Similarly, the typing and final compilation of the manuscript by Mrs. H. M. Holleman in the short time available is greatly appreciated. The Energy Technology branch of the Reactor Research and Technology Division (ET/RRT) of DOE (P. B. Hemmig) provides general support for the ENDF/B data and particular support for the CINDER-10 Code. The EPRI-CINDER Code and libraries are supported by the Electric Power Research Institute (O. Ozer).

REFERENCES

1. T. R. England, Los Alamos Scientific Laboratory, personal communication to R. Schamberger (April 1979).
2. T. R. England, R. Wilczynski, and N. L. Whittemore, "CINDER-7: An Interim Report for Users," Los Alamos Scientific Laboratory report LA-5885-MS (1975).

3. T. R. England, W. B. Wilson, and M. G. Stamatelatos, "Fission-Product Data for Thermal Reactors, Part 1, A Data Set for EPRI-CINDER Using ENDF/B-IV," Los Alamos Scientific Laboratory report LA-6745-MS (Dec. 1976) and "Fission Product Data for Thermal Reactors, Part 2, Users Manual for EPRI-CINDER Code and Data," Los Alamos Scientific Laboratory report LA-6746-MS (Dec. 1976). [Also published by Electric Power Research Institute as EPRI NP-356 (Dec. 1976)].
4. Fission Product Decay Library of the Evaluated Nuclear Data File, Version IV (ENDF/B-IV). These data were compiled by a task force chaired by R. E. Schenter and are available from and maintained by the National Nuclear Data Center at the Brookhaven National Laboratory.
5. T. R. England and R. E. Schenter, "ENDF/B-IV Fission-Product Files: Summary of Major Nuclide Data," Los Alamos Scientific Laboratory report LA-6116-MS [ENDF-223] (October 1975).
6. P. F. Rose and T. W. Burrows, "ENDF/B Fission-Product Decay Data," Brookhaven National Laboratory report BNL-NCS-50545 [ENDF-243], Vols. 1 and 2 (August 1976, issued May 1977). Also see C. W. Riech, R. G. Helmer, and M. H. Putnam, "Radioactive-Nuclide Decay Data for ENDF/B," Areojet Nuclear Company report ANCR-1157 [ENDF-120] (August 1974).
7. "ARMP: Advanced Recycle Methodology Program," Chap. 5, Part II, "EPRI-CELL Code Description," Proprietary Electric Power Research Institute report CCM-3 (Sept. 1977).
8. W. B. Wilson and T. R. England, "Multigroup and Few-Group Cross Sections for ENDF/B-IV Fission Products: The TOAFEW Collapsing Code and Data File of 154-Group Fission-Product Cross Sections," Los Alamos Scientific Laboratory report LA-7174-MS (March 1978).
9. R. E. MacFarlane, R. J. Barrett, D. W. Muir, and R. M. Boicourt, "The NJOY Nuclear Data Processing System: User's Manual," Los Alamos Scientific Laboratory report LA-7584-MS (December 1978).
10. T. R. England, R. E. Schenter, and F. Schmittroth, "Integral Decay-Heat Measurements and Comparisons to ENDF/B-IV and V," Los Alamos Scientific Laboratory report NUREG/CR-0305 LA-7422-MS (August 1978). (See also Electric Power Research Institute report EPRI-NP-1098, Sec. 10-1 for a copy of the primary data in this report.)
11. R. E. Schenter, F. Schmittroth, and T. R. England, "Integral Determination of Fission Product Inventory and Decay Power," Proc. Second Advisory Group Meeting on Fission Product Nuclear Data, ECN, Petten, IAEA-213, Vol. II, RP15 (Sept. 1977).
12. American Nuclear Society Proposed ANS 5.1 Standard, "Decay Heat Power in Light Water Reactors," (June 1978 [Rev. Sept. 1978]).
13. Virgil E. Schrock, "Evaluation of Decay Heating in Shutdown Reactors," Progress in Nuclear Energy, 3, 125-156 (1979).

14. W. B. Wilson, T. R. England, and R. J. LaBauve, Los Alamos Scientific Laboratory, personal communication regarding DKPOWR Code.
15. W. B. Wilson, T. R. England, O. Ozer, and D. E. Wessol, "Actinide Decay Power," Trans. Am. Nucl. Soc. 32, 737 (June 1979).

APPENDIX A

THE 1978 ANS 5.1 DECAY POWER STANDARD FOR LIGHT WATER REACTORS: SUMMARY OF DATA USED IN THIS REPORT

The new standard is represented by pulse functions as discussed in the main text of this report [Eqs. (1) and (2)]. The actual standard lists the parameters for the functions and uses these to generate tabular heating rates vs cooling at six points per time decade between 1 and 10^{13} s for the pulse and 1 and 10^9 s for the "infinite irradiation" for ^{235}U , ^{239}Pu and ^{238}U . The user has the option of using the functions, as in this report, or the tabular data as explained in the standard.

The infinite irradiation case is actually generated from Eq. (2) where each fuel is assumed to produce power at a constant fission rate without depletion. This is an artifice that permits, in principle, the same informational content in the tabular data as is contained in the pulse functions.

Neither the pulse functions nor the tabular data account for the effect of neutron absorption by fission-products. This is dependent on the specific reactor and its power history. As noted in the text, the net effect of neutron absorption for cooling times $<10^4$ s is small even following a long irradiation time. The standard accounts for this with an empirical equation up to 10^4 s and an "upper bound" based on two CINDER-10 summation calculations for a very long irradiation period (4 years) at large flux levels. The user has the option of using the upper bound at any cooling time and also of using documented summation calculations at any time. The upper bound correction, tabulated in Table A-I and plotted in Fig. A-1, is inappropriate for the short life of TMI-2. It was used only for the first 4×10^4 s, and only where so indicated in the tabular data. For longer times the direct CINDER results were used because these already include the absorption effect.

The pulse function parameters are listed in Table A-II. These are used in the DKPOWR code with fission rates from CINDER to produce aggregate heating rates up to 4×10^4 s, except in the detailed CINDER-10 data in Appendices B and C. Fissioning nuclides other than ^{235}U , ^{239}Pu and ^{238}U are assigned the ^{235}U values when the standard is used.

Variable mixtures of fission rates, including uncertainties, can be treated as discussed in the standard. The DKPOWR Code describes this in more detail, including some clarification of aspects that may be of interest to users of the standard.

One problem that confronts the user is the treatment of uncertainties when using the pulse functions. The DKPOWR Code incorporates an extremely accurate fit to the absolute 1σ uncertainties, Δf , in f of Eq. (1). These give Δf as a function identical in form to Eq. (1) but with different parameters,

$$\Delta f = \sum_{i=1}^{23} \beta_i e^{-\gamma_i t} \text{ MeV/fiss-s} \quad (\text{A-1})$$

The parameters (β , γ) are listed in Table A-III but are not included in the standard. The standard provides tabular data and users must interpolate to get appropriate values of Δf .

The decay heating or power in the units of MeV/fiss represent the decay energy release rate in MeV/s at specified or listed cooling times normalized to the fission rate during power

$$\text{MeV/fiss} \equiv \frac{\text{MeV/s}}{\text{Fiss/s}} \quad (\text{A-2})$$

Such units are meaningful only for the case of a constant fission rate during the powered interval. The release rate in MeV/s can be obtained using a sum of the integrals of the product of each pulse function and the corresponding fission rate of each fuel. In this report we have represented the variable power history of TMI-2 as a series of histograms, using the rates in Table II. The fission product decay power at any specific cooling time has been accumulated from the separate contributions of each histogram. The units of MeV/s can be readily converted to MW using the relationship $1 \text{ MeV/s} = 1.60207 \times 10^{-19} \text{ MW}$.

Figure A-2 shows the absolute comparison of heating rates for a single fission pulse for each of the three fuels. The differences are emphasized in Fig.

A-3 which show the deviations of ^{239}Pu and ^{238}U from ^{235}U for the infinite irradiation case. Figure A-4 shows the new standard for ^{235}U and its small uncertainty compared to the older standard and its uncertainty.

TABLE A-I
RATIO OF DECAY HEAT WITH ABSORPTION TO
VALUES WITHOUT ABSORPTION^a

Time After Shutdown (sec)	$G_{\text{max}}(t)$	Time After Shutdown (sec)	$G_{\text{max}}(t)$
1.0	1.020	1.5E+5	1.130
1.5	1.020	2.0E+5	1.131
2.0	1.020	4.0E+5	1.126
4.0	1.021	6.0E+5	1.124
6.0	1.022	8.0E+5	1.123
8.0	1.022	1.0E+6	1.124
1.0E+1	1.022	1.5E+6	1.125
1.5E+1	1.022	2.0E+6	1.127
2.0E+1	1.022	4.0E+6	1.134
4.0E+1	1.022	6.0E+6	1.146
6.0E+1	1.022	8.0E+6	1.162
8.0E+1	1.022	1.0E+7	1.181
1.0E+2	1.023	1.5E+7	1.233
1.5E+2	1.024	2.0E+7	1.284
2.0E+2	1.025	4.0E+7	1.444
4.0E+2	1.028	6.0E+7	1.535
6.0E+2	1.030	8.0E+7	1.586
8.0E+2	1.032	1.0E+8	1.598
1.0E+3	1.033	1.5E+8	1.498
1.5E+3	1.037	2.0E+8	1.343
2.0E+3	1.039	4.0E+8	1.065
4.0E+3	1.048	6.0E+8	1.021
6.0E+3	1.054	8.0E+8	1.012
8.0E+3	1.060	1.0E+9	1.007
1.0E+4	1.064		
1.5E+4	1.074		
2.0E+4	1.081		
4.0E+4	1.098		
6.0E+4	1.111		
8.0E+4	1.119		
1.0E+5	1.124		

^aRatio Based on: ^{235}U thermal fission for 4 years, no depletion, typical LWR spectrum.

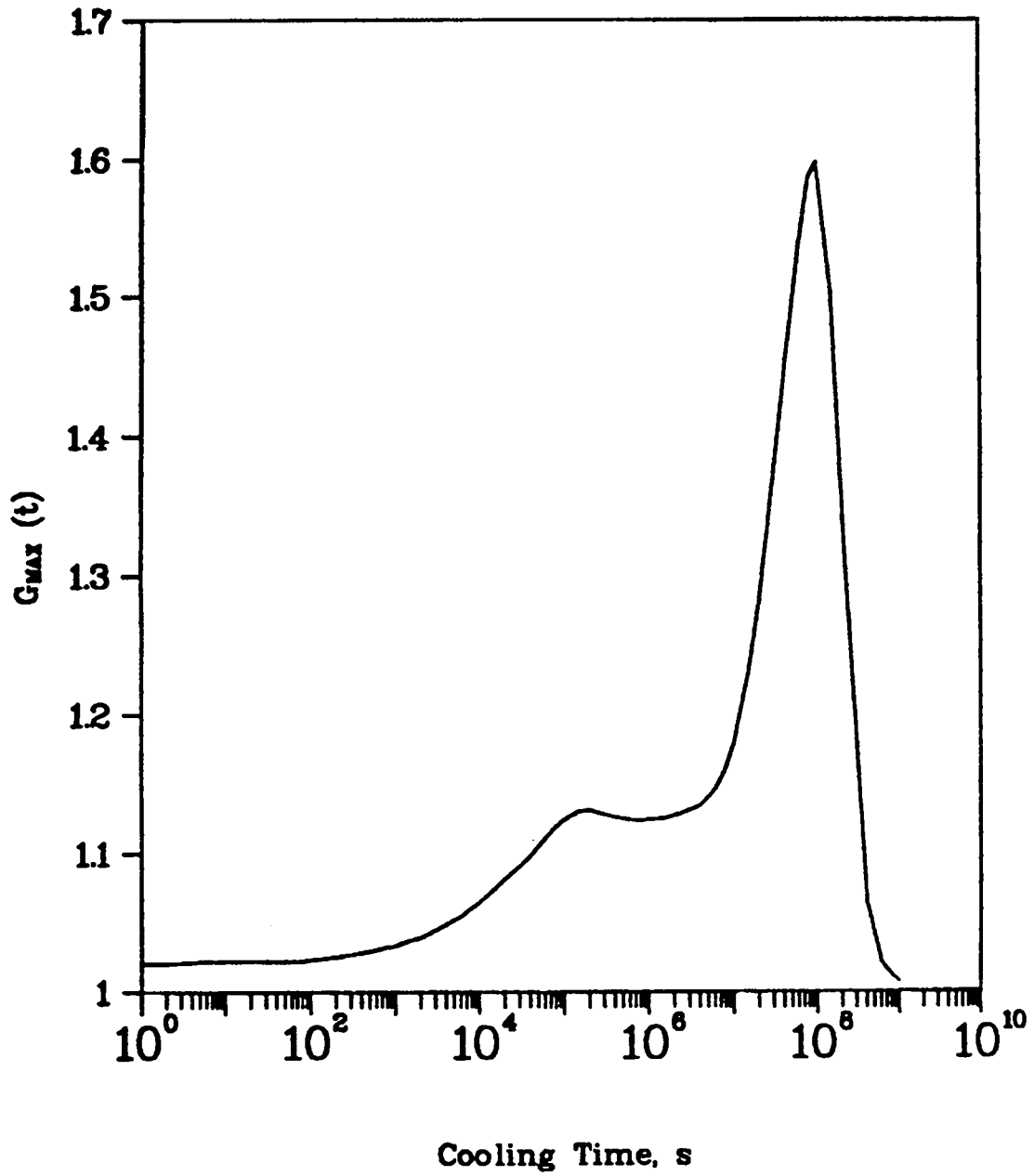

Fig. A-1.
ANS 5.1 Standard upper-bound
absorption correction G_{\max} .

TABLE A-II
 PARAMETERS
 FOR
 PULSE AND FINITE IRRADIATION DECAY-HEAT
 FUNCTIONS $f(t)$ and $F(t,T)$
 (5/78)

U-235 Thermal		U-238 Fast		Pu-239 Thermal	
α	λ	α	λ	α	λ
6.5057E-01	2.2138E+01	1.2311E+00	3.2881E+00	2.0830E-01	1.0020E+01
5.1264E-01	5.1587E-01	1.1486E+00	9.3805E-01	3.8530E-01	6.4330E-01
2.4384E-01	1.9594E-01	7.0701E-01	3.7073E-01	2.2130E-01	2.1860E-01
1.3850E-01	1.0314E-01	2.5209E-01	1.1118E-01	9.4600E-02	1.0040E-01
5.5440E-02	3.3656E-02	7.1870E-02	3.6143E-02	3.5310E-02	3.7280E-02
2.2225E-02	1.1681E-02	2.8291E-02	1.3272E-02	2.2920E-02	1.4350E-02
3.3088E-03	3.5870E-03	6.8392E-03	5.0133E-03	3.9460E-03	4.5490E-03
9.3015E-04	1.3930E-03	1.2322E-03	1.3655E-03	1.3170E-03	1.3280E-03
8.0943E-04	6.2630E-04	6.8409E-04	5.5158E-04	7.0520E-04	5.3560E-04
1.9567E-04	1.8906E-04	1.6975E-04	1.7873E-04	1.4320E-04	1.7300E-04
3.2535E-05	5.4988E-05	2.4182E-05	4.9032E-05	1.7650E-05	4.8810E-05
7.5595E-06	2.0958E-05	6.6356E-06	1.7058E-05	7.3470E-06	2.0060E-05
2.5232E-06	1.0010E-05	1.0075E-06	7.0465E-06	1.7470E-06	8.3190E-06
4.9948E-07	2.5438E-06	4.9894E-07	2.3190E-06	5.4810E-07	2.3580E-06
1.8531E-07	6.6361E-07	1.6352E-07	6.4480E-07	1.6710E-07	6.4500E-07
2.6608E-08	1.2290E-07	2.3355E-08	1.2649E-07	2.1120E-08	1.2780E-07
2.2396E-09	2.7213E-08	2.8094E-09	2.5548E-08	2.9960E-09	2.4660E-08
8.1641E-12	4.3714E-09	3.6236E-11	8.4782E-09	5.1070E-11	9.3780E-09
8.7797E-11	7.5780E-10	6.4577E-11	7.5130E-10	5.7300E-11	7.4500E-10
2.5131E-14	2.4786E-10	4.4963E-14	2.4188E-10	4.1380E-14	2.4260E-10
3.2176E-16	2.2394E-13	3.6654E-16	2.2739E-13	1.0880E-15	2.2100E-13
4.5038E-17	2.4600E-14	5.6293E-17	9.0536E-14	2.4540E-17	2.6400E-14
7.4791E-17	1.5699E-14	7.1602E-17	5.6098E-15	7.5570E-17	1.3800E-14

TABLE A-III

PARAMETERS
FOR
 Δf
THE PULSE FUNCTION UNCERTAINTY*

^{235}U		^{238}U		^{239}Pu	
β	γ	β	γ	β	γ
1.1306+0	2.3079+0	2.6985-1	5.6768-1	1.9530+0	2.1278+0
1.4680+0	2.5578+0	4.6317-1	2.1447+0	1.2000-4	2.0370+2
3.4480-1	2.4554+0	3.3342-2	2.6939-1	3.0310-1	2.1127+0
8.5155-3	2.4783+0	5.2368-2	1.2343-1	2.0617-2	2.1132+0
3.2872-2	3.7832-1	1.6377-2	3.7050-2	2.0761-2	2.5175-1
8.2958-3	1.2756-1	3.3312-3	1.3551-2	4.8726-3	6.8314-2
1.5202-3	3.5541-2	3.4399-4	3.8277-3	1.4982-4	3.3741-3
2.8260-4	1.0309-2	2.9573-5	1.1444-3	1.1519-3	1.4929-2
9.5539-5	6.3926-3	4.5202-5	6.9141-4	4.9044-5	7.0130-4
4.1938-5	1.3593-3	1.2485-5	1.9674-4	2.8594-6	1.1230-4
8.2175-6	2.8126-4	1.4719-6	5.9641-5	4.2090-6	1.7173-4
7.9662-7	5.7595-5	4.3067-7	1.7524-5	4.8789-7	2.4989-5
6.0345-8	8.5336-6	2.8213-8	3.7664-6	1.4067-7	1.0014-5
6.9231-9	2.2085-6	6.0028-9	1.9651-6	2.9496-8	2.4173-6
3.7062-9	6.6361-7	6.3270-9	6.8983-7	8.3735-9	6.4468-7
5.3216-10	1.2290-7	8.9103-10	1.3242-7	1.0591-9	1.2806-7
4.4796-11	2.7213-8	1.1371-10	2.3771-8	1.5014-10	2.4668-8
1.6328-13	4.3714-9	1.4076-12	9.1546-9	2.5438-12	9.4104-9
1.7559-12	7.5780-10	3.2341-12	7.5130-10	2.8675-12	7.4481-10
5.0262-16	2.4786-10	2.2547-15	2.4188-10	2.0731-15	2.4337-10
6.4352-18	2.2384-13	1.8325-17	2.2768-13	5.4574-17	2.2119-13
9.0076-19	2.4600-14	2.8240-18	9.0019-14	1.2296-18	2.6741-14
1.4958-18	1.5699-14	3.5792-18	5.4671-15	3.7807-18	1.3870-14

* These accurately reproduce the 1σ values in Δf of the ANS 5.1 Standard when used in Eq. (A-1), but these parameters are not listed in the standard.

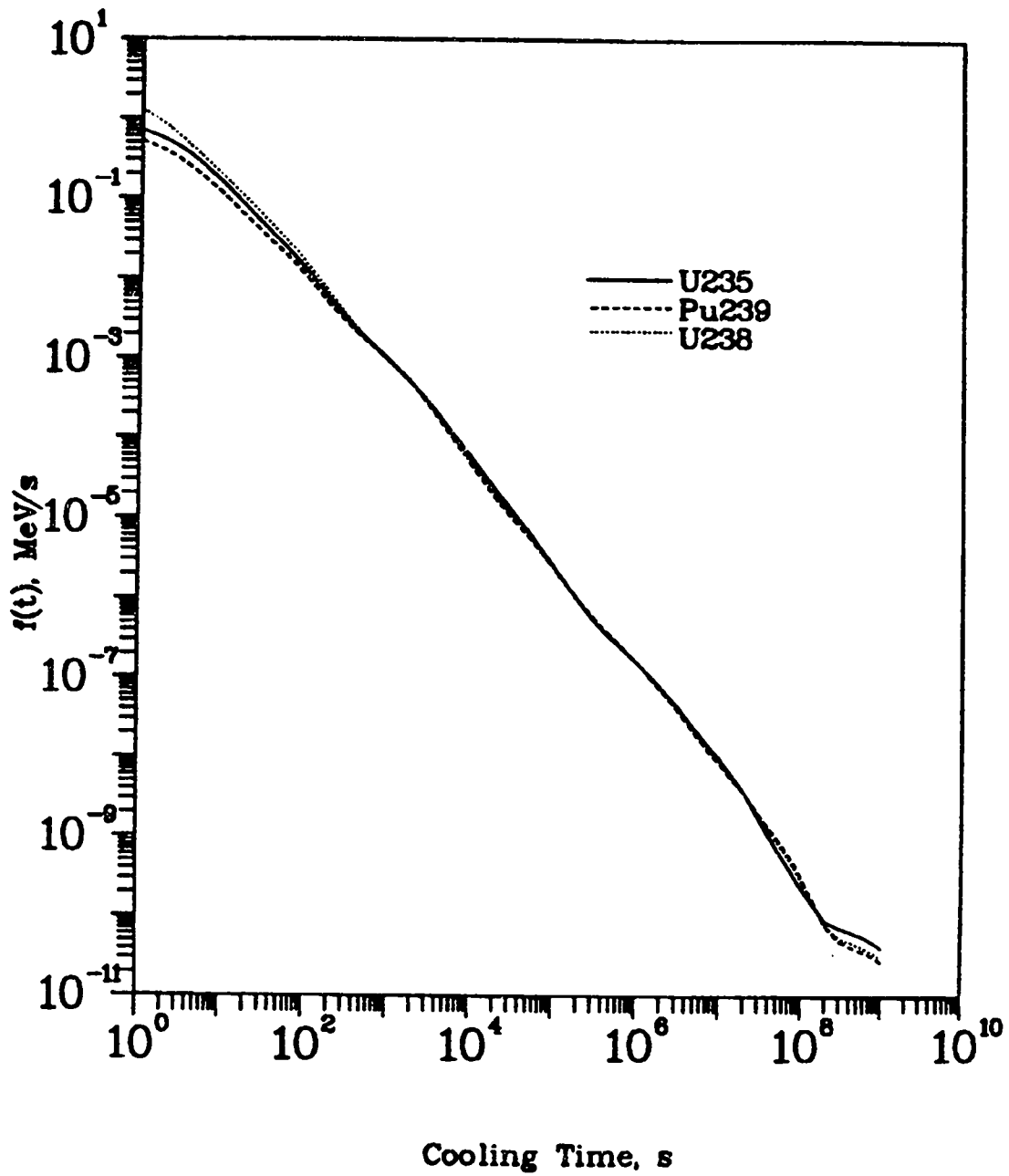

Fig. A-2.
ANS 5.1 Standard fission-product
decay power pulse functions.

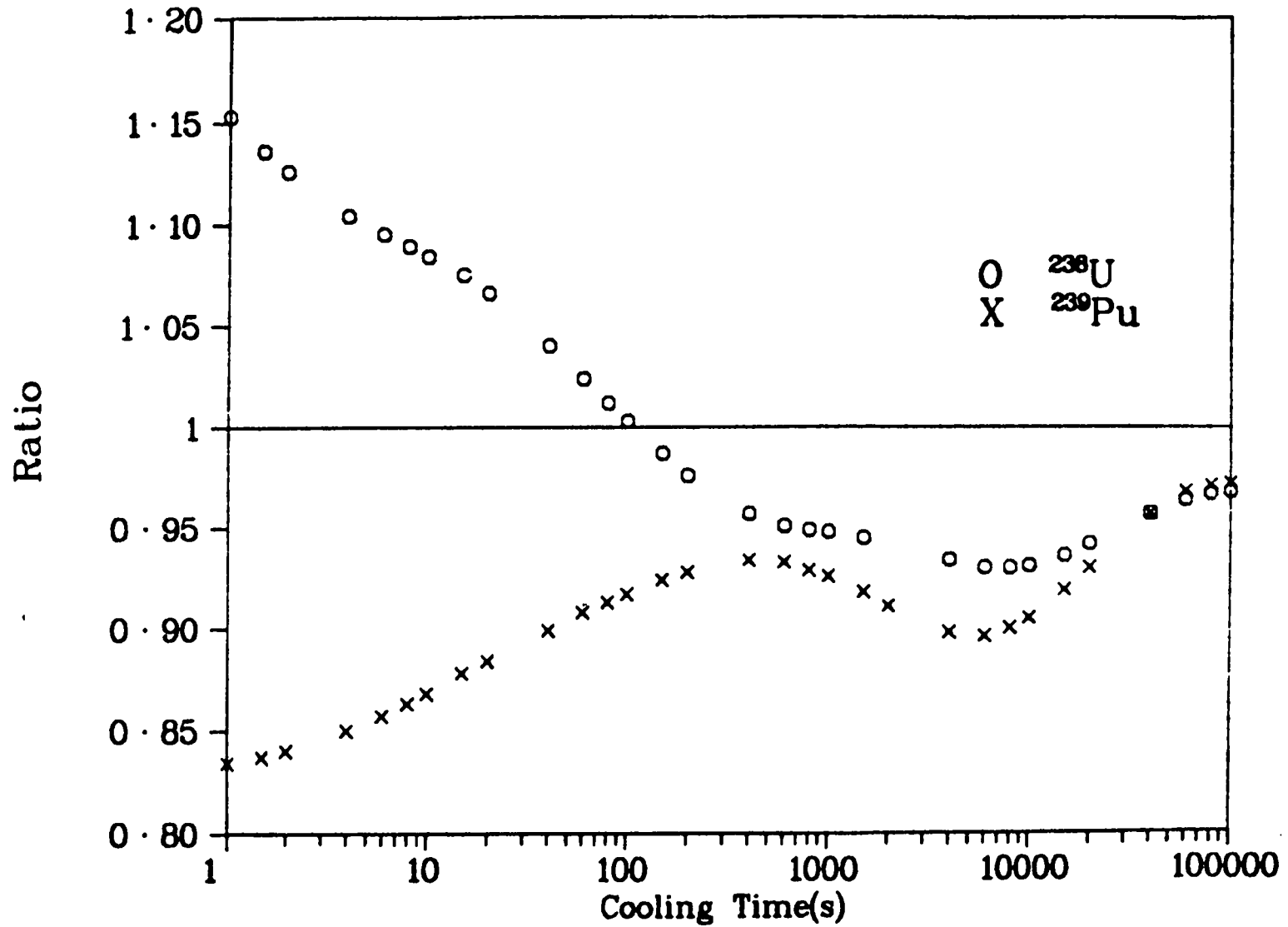

Fig. A-3. Ratio of ^{239}Pu and ^{238}U nominal decay heating to ^{235}U nominal - infinite irradiation.

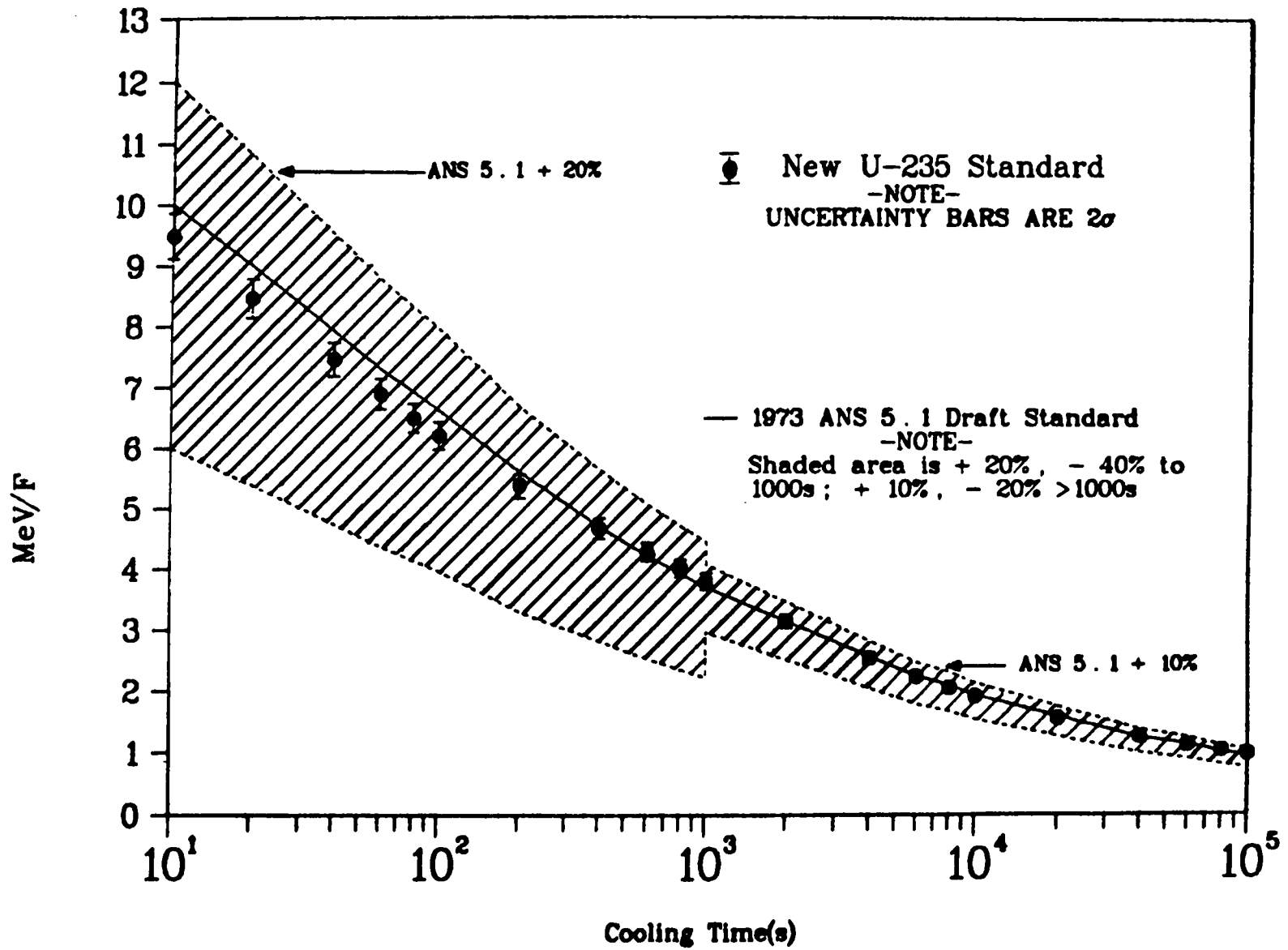

Fig. A-4. Comparison of Standard $F(t, \infty)$ for ^{235}U (1978) with 1973 Standard.

APPENDIX B

TMI-2 CURIES, ATOMS, AND DECAY POWERS OF MAJOR FISSION-PRODUCT CONTRIBUTORS AND COMPARISON RESULTS FOLLOWING AN EXTENDED POWER PERIOD

For the TMI-2 power history and a 26 000 hour irradiation at constant, full power of TMI-2, the CINDER-10 results for collective and individual nuclide contributions at each of 24 cooling times are summarized in this Appendix. At each cooling time (the same times as in the main text plus the instant of shutdown) any nuclide contributing more than 0.5% to the values of the total summations over all fission products of curies, beta, gamma, or beta + gamma energies is listed.

All data are calculated using the ENDF/B-IV data base in CINDER-10 and actinide cross sections from EPRI-CELL as described in the main text. Therefore, the total decay heating from fission products will differ by a small amount from the aggregate values in the main text because of the use there of the ANS 5.1 Standard for times ≤ 20 hours. For cooling times up to a few minutes, the standard is believed to be more accurate than calculations, but as the cooling time increases it is increasingly probable that these summation calculations are more accurate because of the accurate accounting for neutron absorption specific to TMI-2. The absorption effect is discussed in the text, and in Appendices A, D, and E.

Each table of time step data is headed by information for the aggregate sums over all fission products and other data as labeled. The first quantity listed is the time step number, time step 22 representing values at the end of the last time at power before the March 28 incident. The second quantity is the cooling time in seconds; this is 0. at time step 22. The total elapsed time over all time steps follows the cooling time.

All other quantities heading each table are values applicable to the total core. The accumulated fission and total fission products in sum are reduced by the factor 10^{-24} , a common practice in reactor design. The beta, gamma and total (beta + gamma) decay power is specified in MW and in MeV/fiss, the latter unit being

$$\text{MeV/fiss} \equiv \frac{\text{MeV/s}}{\text{fiss/s}} ,$$

where MeV/s is the decay power rate in MeV per second at the specified cooling time and fiss/s is the fission rate during the last time step at power; in this case the rate is 8.27×10^{19} for TMI-2 (for the second set of tables the rate is 8.59×10^{19} fiss/s).

The tabular data for each nuclide consists of the following quantities.

COL	QUANTITY
1	Numerical ID where the first two digits = the atomic number Z, the next three digits = mass number A, the sixth digit specifies the isomeric state (0 = ground, 1 = first isomeric, etc), and the final digit is 0 in all cases.
2	Chemical symbol corresponding to the atomic number.
3-6	Lists percentages for beta, gamma and beta + gamma decay energy of the total, and the percent of curies of the total, where total refers to all fission products.
7-9	Lists the decay power in MeV/fission, as discussed above.
10	Lists curies (total core).
11	Lists the "density" where, in this case, density refers to the total atoms of the nuclide in the core multiplied by the factor 10^{-24} .
12-14	Lists the decay power in MW for beta, gamma and beta + gamma.

As the cooling time increases the number of nuclides meeting the $\geq 0.5\%$ -of-total criteria for inclusion in these tables decreases, particularly for TMI-2. That is, a few nuclides dominate the total decay at long times.

The second set of tables is identical in form to the first set but is based on a constant power of 2772 MW for 26 000 hours (~2.97 years). This case is comparable to 1/3 of the equilibrium core fuel following three cycles. It differs in the following respects:

- All fuel is assumed to produce power constantly for 26 000 hours.
- Each fissionable nuclide is assumed to produce the same energy per fission.
- Fuel cross sections are based on EPRI-CELL at mid-life; that is, these cross sections are self-shielded at the mid-life value but are not time dependent.

The differences are not important for the intended use of these tables, namely, to provide a general comparison of nuclide data for highly irradiated fuel. The number of time steps at power was maintained at 22 and the decay (cooling) times are the same as used for TMI-2 so that time step numbers correspond to the same cooling times as in the first set of tables.

The reader should note that the calculations for the second set of tables uses a power level of 2772 MW. Had TMI-2 been at full power during its last powered interval the fission product decay energy would be increased by ~2.7% for each nuclide during the first day or more following the March 28 incident.

It is interesting to note that the number of nuclides making considerable ($\geq 0.5\%$) contributions to total fission-product decay power far exceed the corresponding number important to total actinide decay power, as shown in Fig. B-1.

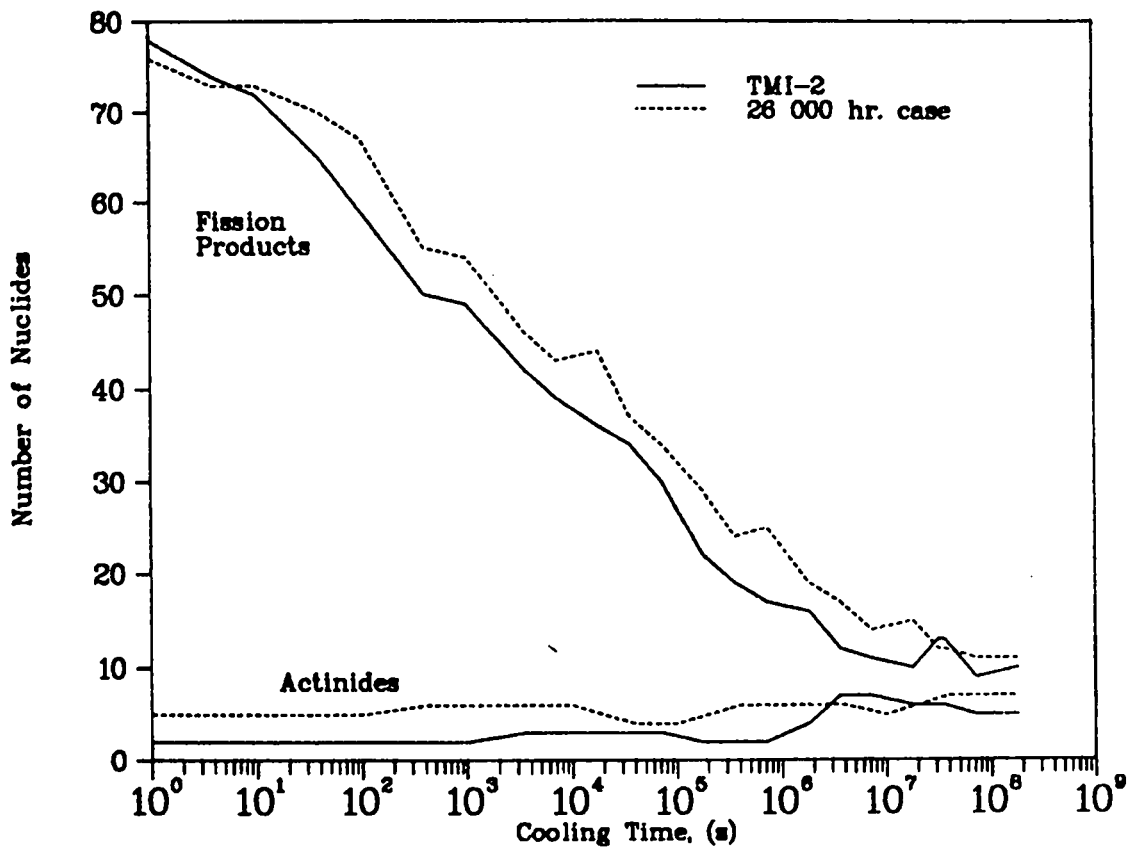

Fig. B-1.
Number of nuclides contributing $\geq 0.5\%$ of total actinide or fission-product decay power.

SPECIAL (LIMITED) PRINT
 ALL FISSION PRODUCTS HAVING BETA, GAMMA, BETA+GAMMA OR CURIES
 EXCEEDING .500 PERCENT OF VALUE FOR ALL PRODUCTS
 (CINDER-10 CALCULATION, END/84 DATA)

TABLE B-1

TMT, UNIT 2, 22-STEP POWER HISTORY, FULL CORE CALC., CINDER-10(LASL) 7/79

22=TIME STEP
 0. =TOTAL TIME SINCE LAST TIME AT POWER(S)
 2.93378E+07=TOTAL ELAPSED TIME(S)
 8.26531E+19=FISSIONS/S AT LAST TS AT POWER, (22)
 2.69970E+09=POWER (WATTS) AT LAST TS AT POWER (2.69970E+03 MW)
 6.95228E+02=ACCUMULATED FISSIONS (FISSIONS PER BARN-CM)
 1.39000E+03=TOTAL FP IN SUM PER BARN-CM

4.61186E+20=TOTAL ACTIVITY (DTS/S)
 1.24645E+10=TOTAL CURIES
 8.28859E+01=TOTAL BETA DECAY POWER (MW)
 7.90085E+01=TOTAL GAMMA DECAY POWER (MW)
 1.61894E+02=TOTAL DECAY POWER (MW)
 6.25950E+00=TOTAL BETA MEV/F
 5.96669E+00=TOTAL GAMMA MEV/F
 1.22262E+01=TOTAL DECAY MEV/F

ID ZZAAAS	SYM	PERCENT OF ALL FP				MEV/FISS			CURIES	DENSITY	---DECAY POWER IN MW---		
		BETA	GAMMA	TOTAL	CURIES	BETA	GAMMA	TOTAL			BETA	GAMMA	TOTAL
350R700	BR	.678	.575	.628	.356	4.245E-02	3.432E-02	7.677E-02	4.441E+07	1.323E-04	5.621E-01	4.544E-01	1.017E+00
350R800	BR	1.112	.715	.914	.407	4.960E-02	4.269E-02	1.123E-01	5.069E+07	4.302E-05	9.216E-01	5.652E-01	1.487E+00
360H800	KR	.129	1.206	.655	.593	4.089E-03	7.197E-02	8.006E-02	7.269E+07	3.911E-02	1.071E-01	9.530E-01	1.060E+00
370H800	RB	1.093	.971	.741	.599	6.844E-02	2.215E-02	9.058E-02	7.341E+07	4.161E-03	9.062E-01	2.932E-01	1.199E+00
350H900	BR	.780	.574	.681	.311	4.883E-02	3.439E-02	8.322E-02	3.875E+07	9.309E-06	6.467E-01	4.553E-01	1.102E+00
3609900	KR	.832	1.451	1.134	.752	5.209E-02	8.658E-02	1.387E-01	9.375E+07	9.488E-04	6.898E-01	1.146E+00	1.836E+00
370A900	RB	.649	1.474	1.190	.783	4.060E-02	9.999E-02	1.406E-01	9.758E+07	4.750E-03	5.375E-01	1.324E+00	1.862E+00
380A900	SR	.261	0.200	.134	.504	1.636E-02	0.	1.636E-02	6.279E+07	1.506E+01	2.166E-01	0.	2.166E-01
3509000	RR	.635	.459	.549	.212	3.973E-02	2.740E-02	6.712E-02	2.643E+07	2.257E-06	5.261E-01	3.628E-01	8.888E-01
3609000	KR	.406	1.244	1.021	.742	3.047E-02	7.436E-02	1.248E-01	9.497E+07	1.637E-04	6.683E-01	9.847E-01	1.653E+00
3709000	RR	1.128	1.898	1.574	.763	7.061E-02	1.132E-01	1.837E-01	9.509E+07	8.223E-04	9.349E-01	1.500E+00	2.435E+00
3709010	RB	.192	.458	.419	.195	1.201E-02	3.925E-02	5.126E-02	2.425E+07	3.324E-04	1.590E-01	5.198E-01	6.788E-01
3609100	KR	1.314	.387	.842	.572	8.226E-02	2.309E-02	1.053E-01	7.128E+07	3.310E-05	1.089E+00	3.057E-01	1.395E+00
3709100	RB	1.115	2.394	1.740	.937	6.978E-02	1.429E-01	2.127E-01	1.168E+08	3.630E-04	9.239E-01	1.893E+00	2.817E+00
3809100	SR	.563	.630	.574	.949	3.527E-02	3.760E-02	7.287E-02	1.208E+08	2.201E-01	4.671E-01	4.979E-01	9.650E-01
3909100	Y	.317	.001	.153	.584	1.982E-02	8.698E-05	1.990E-02	7.305E+07	1.974E+01	2.624E-01	1.152E-03	2.636E-01
3909110	Y	0.000	.290	.141	.558	0.	1.729E-02	1.729E-02	6.959E+07	1.108E-02	0.	2.290E-01	2.290E-01
3609200	KR	.567	.194	.341	.765	3.549E-02	1.110E-02	4.658E-02	3.298E+07	3.239E-06	4.698E-01	1.470E-01	6.168E-01
3709200	RB	2.440	.123	1.343	.791	1.527E-01	1.154E-02	1.643E-01	9.862E+07	2.385E-05	2.022E+00	1.528E-01	2.175E+00
3809200	SR	.149	1.234	.688	.985	1.057E-02	7.360E-02	8.418E-02	1.228E+08	6.396E-02	1.400E-01	9.746E-01	1.115E+00
3909200	Y	1.289	.229	.772	.987	8.067E-02	1.367E-02	9.434E-02	1.231E+08	8.349E-02	1.068E+00	1.811E-01	1.249E+00
3709300	RB	1.085	.794	.943	.600	6.791E-02	4.739E-02	1.153E-01	7.483E+07	2.317E-05	8.993E-01	4.275E-01	1.527E+00
3809300	SR	1.092	1.374	1.220	1.055	6.833E-02	8.210E-02	1.504E-01	1.315E+08	3.158E-03	9.048E-01	1.087E+00	1.992E+00
3909300	Y	1.134	.090	.625	1.074	7.099E-02	5.368E-03	7.636E-02	1.339E+08	2.624E-01	9.400E-01	7.108E-02	1.011E+00

5513900	CS	1.766	.326	1.064	1.121	1.106E-01	1.948E-02	1.300E-01	1.400E+08	4.171E-03	1.464E+00	2.580E-01	1.722E+00
5613900	BA	.913	.056	.495	1.141	5.714E-02	3.330E-03	6.047E-02	1.422E+08	3.795E-02	7.566E-01	4.409E-02	8.007E-01
5414000	XE	.493	.807	.643	.629	3.085E-02	4.772E-02	7.857E-02	7.825E+07	5.681E-05	4.085E-01	6.319E-01	1.040E+00
5514000	CS	1.754	2.030	1.899	1.017	1.098E-01	1.211E-01	2.309E-01	1.270E+08	4.325E-04	1.454E+00	1.604E+00	3.058E+00
5614000	BA	.255	.207	.231	1.017	1.593E-02	1.233E-02	2.826E-02	1.270E+08	7.492E+00	2.110E-01	1.633E-01	3.743E-01
5714000	LA	.466	2.175	1.300	1.011	2.917E-02	1.298E-01	1.589E-01	1.260E+08	9.743E-01	3.862E-01	1.718E+00	2.104E+00
5514100	CS	.950	1.321	1.131	.774	5.948E-02	7.883E-02	1.383E-01	9.650E+07	1.288E-04	7.877E-01	1.044E+00	1.832E+00
5614100	BA	.842	.857	.849	1.032	5.271E-02	5.112E-02	1.039E-01	1.286E+08	7.538E-03	6.979E-01	6.769E-01	1.375E+00
5714100	LA	.914	.032	.683	1.036	5.720E-02	1.896E-03	5.909E-02	1.291E+08	9.599E-02	7.574E-01	2.510E-02	7.825E-01
5814100	CE	.111	.052	.082	.779	6.936E-03	3.118E-03	1.005E-02	9.715E+07	1.458E+01	9.185E-02	4.129E-02	1.331E-01
5514200	CS	.206	1.183	1.041	.497	5.672E-02	7.058E-02	1.273E-01	6.197E+07	5.623E-06	7.511E-01	9.346E-01	1.686E+00
5614200	BA	.388	.964	.649	1.018	2.432E-02	5.750E-02	8.181E-02	1.268E+08	4.346E-03	3.220E-01	7.614E-01	1.083E+00
5714200	LA	.875	2.324	1.583	1.036	5.476E-02	1.388E-01	1.935E-01	1.292E+08	3.823E-02	7.251E-01	1.838E+00	2.563E+00
5514300	CS	.377	.549	.440	.270	2.359E-02	3.271E-02	5.630E-02	3.369E+07	3.057E-06	3.124E-01	4.331E-01	7.454E-01
5614300	BA	.889	1.345	1.112	.915	5.565E-02	8.025E-02	1.359E-01	1.142E+08	8.289E-05	7.369E-01	1.063E+00	1.799E+00
5714300	LA	.757	1.000	.919	1.021	4.737E-02	6.501E-02	1.124E-01	1.273E+08	5.708E-03	6.273E-01	8.609E-01	1.488E+00
5814300	CE	.383	.284	.335	1.026	2.400E-02	1.694E-02	4.094E-02	1.279E+08	8.112E-01	3.178E-01	2.243E-01	5.421E-01
5914300	PR	.269	0.000	.138	.932	1.685E-02	0.	1.685E-02	1.162E+08	7.278E+00	2.231E-01	0.	2.231E-01
5614400	BA	.424	.719	.557	.734	2.652E-02	4.283E-02	6.935E-02	9.145E+07	5.369E-05	3.512E-01	5.671E-01	9.183E-01
5714400	LA	1.247	1.477	1.456	.926	7.803E-02	1.000E-01	1.781E-01	1.134E+08	2.464E-04	1.033E+00	1.325E+00	2.358E+00
5614500	BA	.409	.642	.523	.357	2.563E-02	3.828E-02	6.391E-02	4.450E+07	1.473E-05	3.394E-01	5.069E-01	8.463E-01
5714500	LA	.610	.918	.740	.644	3.816E-02	5.479E-02	9.295E-02	8.055E+07	1.247E-04	5.052E-01	7.255E-01	1.231E+00
5814500	CE	.386	.482	.433	.698	2.417E-02	2.873E-02	5.290E-02	8.570E+07	9.058E-04	3.200E-01	3.804E-01	7.004E-01
5914500	PR	.432	.009	.225	.699	2.704E-02	5.288E-04	2.757E-02	8.572E+07	9.851E-02	3.580E-01	7.002E-03	3.650E-01
5714600	LA	.650	.910	.777	.413	4.071E-02	5.429E-02	9.499E-02	5.144E+07	2.279E-05	5.390E-01	7.189E-01	1.258E+00
5814600	CE	.115	.156	.135	.532	7.203E-03	9.328E-03	1.653E-02	6.630E+07	3.015E-03	9.538E-02	1.235E-01	2.189E-01
5914600	PR	.441	.816	.624	.936	2.762E-02	4.867E-02	7.630E-02	6.650E+07	5.154E-03	3.658E-01	6.445E-01	1.010E+00
5914800	PR	.562	.087	.330	.309	3.519E-02	5.167E-03	4.036E-02	3.847E+07	2.464E-04	4.660E-01	6.842E-02	5.345E-01

TABLE B-II

TIME UNIT 2, 22-STEP POWER HISTORY, FULL CORE CALC., CINDER-10(LASL) 7779

23=TIME STEP
1.00000E+00=TOTAL TIME SINCE LAST TIME AT POWER(S)
2.93378E+07=TOTAL ELAPSED TIME(S)
8.26531E+19=FISSIONS/S AT LAST TS AT POWER (22)
2.69970E+09=POWER (WATTS) AT LAST TS AT POWER (2.69970E+03 MW)
6.95228E+02=ACCUMULATED FISSIONS (FISSIONS PER BARN-CM)
1.39000E+03=TOTAL FP TN SUM PER BARN-CM

4.39726E+20=TOTAL ACTIVITY (DIS/S)
1.18845E+10=TOTAL CURIES
7.53147E+01=TOTAL BETA DECAY POWER (MW)
7.32734E+01=TOTAL GAMMA DECAY POWER (MW)
1.48588E+02=TOTAL DECAY POWER (MW)
5.68773E+00=TOTAL BETA MFV/F
5.53358E+00=TOTAL GAMMA MFV/F
1.12213E+01=TOTAL DECAY MFV/F

TABLE B-III

TMT, UNIT 2, 22-STEP POWER HISTORY, FULL CORE CALC., CINDER-10(LASL) 7/79

24=TIME STEP
 4.00000E+00=TOTAL TIME SINCE LAST TIME AT POWER(S)
 2.93378E+07=TOTAL ELAPSED TIME(S)
 8.26531E+19=FISSIONS/S AT LAST TS AT POWER (22)
 2.69970E+09=POWER (WATTS) AT LAST TS AT POWER (2.69970E+03 MW)
 6.95228E+02=ACCUMULATED FISSIONS (FISSIONS PER BARN-CM)
 1.39000E+03=TOTAL FP IN SIM PER BARN-CM

4.09939E+20=TOTAL ACTIVITY (DIS/S)
 1.10794E+10=TOTAL CURIES
 6.59891E+01=TOTAL BETA DECAY POWER (MW)
 6.64534E+01=TOTAL GAMMA DECAY POWER (MW)
 1.32443E+07=TOTAL DECAY POWER (MW)
 4.98347E+00=TOTAL BETA MFV/F
 5.01853E+00=TOTAL GAMMA MFV/F
 1.00020E+01=TOTAL DECAY MFV/F

ID ZAAAS	SYM	-----PERCENT OF ALL FP-----				-----MEV/FISS-----				---DECAY POWER IN MW---			
		BETA	GAMMA	TOTAL	CURIES	BETA	GAMMA	TOTAL	CURIES	DENSITY	BETA	GAMMA	TOTAL
3509600	BR	.298	.554	.427	.169	1.487E-02	2.779E-02	4.266E-02	1.871E+07	3.494E-03	1.969E-01	3.680E-01	5.649E-01
3508700	BR	.826	.663	.744	.399	4.115E-02	3.326E-02	7.441E-02	4.304E+07	1.282E-04	5.449E-01	4.405E-01	9.854E-01
3608700	KR	.614	.367	.498	.463	3.062E-02	1.819E-02	4.881E-02	5.126E+07	1.248E-02	4.055E-01	2.408E-01	6.463E-01
3508800	BR	1.188	.773	.955	.389	9.919E-02	3.630E-02	9.549E-02	4.311E+07	3.659E-05	7.838E-01	4.807E-01	1.264E+00
3608800	KR	.162	1.434	.890	.654	8.088E-03	7.197E-02	8.005E-02	7.268E+07	3.911E-02	1.071E-01	9.529E-01	1.060E+00
3708800	RB	1.373	.441	.906	.663	6.844E-02	2.215E-02	9.058E-02	7.341E+07	4.161E-03	9.062E-01	2.932E-01	1.199E+00
3508900	BR	.532	.377	.457	.190	2.651E-02	1.867E-02	4.518E-02	2.104E+07	5.054E-06	3.511E-01	2.472E-01	5.983E-01
3608900	KR	1.035	1.708	1.373	.838	5.157E-02	8.571E-02	1.373E-01	9.281E+07	9.393E-04	6.828E-01	1.135E+00	1.818E+00
3708900	RB	.814	1.997	1.405	.891	4.059E-02	9.997E-02	1.406E-01	9.757E+07	4.750E-03	5.375E-01	1.324E+00	1.861E+00
3808900	SR	.328	0.000	.164	.567	1.636E-02	0.	1.636E-02	6.279E+07	1.506E+01	2.166E-01	0.	2.166E-01
3609000	KR	.940	1.374	1.159	.796	4.686E-02	6.905E-02	1.159E-01	8.819E+07	1.521E-04	6.205E-01	9.144E-01	1.535E+00
3709000	RB	1.413	2.750	1.833	.856	7.039E-02	1.129E-01	1.833E-01	9.481E+07	8.198E-04	9.321E-01	1.495E+00	2.427E+00
3709010	RB	.240	.779	.510	.218	1.196E-02	3.909E-02	5.104E-02	2.415E+07	3.310E-04	1.583E-01	5.176E-01	6.759E-01
3609100	KR	1.211	.337	.773	.472	6.034E-02	1.694E-02	7.728E-02	5.229E+07	2.428E-05	7.990E-01	2.243E-01	1.023E+00
3709100	RB	1.369	2.788	2.090	1.031	6.823E-02	1.398E-01	2.080E-01	1.142E+08	3.549E-04	9.035E-01	1.851E+00	2.755E+00
3809100	SR	.708	.749	.729	1.097	3.527E-02	3.760E-02	7.287E-02	1.208E+08	2.201E-01	4.671E-01	4.979E-01	9.650E-01
3909100	Y	.398	.007	.197	.659	1.982E-02	8.698E-05	1.990E-02	7.309E+07	1.974E+01	2.624E-01	1.152E-03	2.636E-01
3909110	Y	0.000	.345	.173	.628	0.	1.729E-02	1.729E-02	6.959E+07	1.108E-02	0.	2.290E-01	2.290E-01
3709200	RB	1.887	.142	1.011	.548	9.403E-02	7.104E-03	1.011E-01	6.072E+07	1.468E-05	1.245E+00	9.407E-02	1.339E+00
3809200	SR	.212	1.447	.847	1.198	1.057E-02	7.360E-02	8.417E-02	1.228E+08	6.395E-02	1.400E-01	9.745E-01	1.115E+00
3909200	Y	1.619	.277	.943	1.111	8.067E-02	1.367E-02	9.434E-02	1.231E+08	8.349E-02	1.068E+00	1.811E-01	1.249E+00
3709300	RB	.876	.607	.741	.434	4.367E-02	3.047E-02	7.415E-02	4.812E+07	1.490E-05	5.783E-01	4.035E-01	9.818E-01
3809300	SR	1.367	1.631	1.499	1.193	6.811E-02	8.183E-02	1.499E-01	1.310E+08	3.148E-03	9.019E-01	1.084E+00	1.985E+00
3909300	Y	1.425	.107	.743	1.708	7.099E-02	5.368E-03	7.636E-02	1.339E+08	2.624E-01	9.400E-01	7.108E-02	1.011E+00
3809400	SR	.965	1.349	1.147	1.115	4.808E-02	6.869E-02	1.169E-01	1.235E+08	4.984E-04	6.366E-01	9.096E-01	1.546E+00
3909400	Y	2.093	1.194	1.642	1.725	1.043E-01	5.990E-02	1.642E-01	1.357E+08	8.257E-03	1.381E+00	7.932E-01	2.174E+00
3809500	SR	1.818	1.267	1.547	.947	9.060E-02	6.360E-02	1.542E-01	1.044E+08	1.448E-04	1.200E+00	8.422E-01	2.042E+00
3909500	Y	2.162	.600	1.378	1.244	1.077E-01	3.013E-02	1.379E-01	1.378E+08	4.636E-03	1.426E+00	3.990E-01	1.825E+00
4009500	ZR	.082	.518	.371	.717	4.107E-03	2.600E-02	3.010E-02	7.889E+07	2.383E+01	5.438E-02	3.442E-01	3.986E-01
3909600	Y	2.780	1.674	2.225	1.160	1.385E-01	8.401E-02	2.225E-01	1.285E+08	9.465E-04	1.834E+00	1.112E+00	2.947E+00
4009700	ZR	.833	.217	.521	1.183	4.149E-02	1.066E-02	5.215E-02	1.311E+08	4.231E-01	5.494E-01	1.412E-01	6.906E-01
4109700	NR	.553	.799	.474	1.198	2.757E-02	3.989E-02	6.746E-02	1.316E+08	3.103E-02	3.651E-01	5.282E-01	8.933E-01

5814300	CF	.482	.339	.409	1.155	2.400E-02	1.694E-02	4.094E-02	1.279E+08	8.112E-01	3.178E-01	2.243E-01	5.421E-01
5914300	PR	.338	0.000	.158	1.049	1.685E-02	0.	1.685E-02	1.162E+08	7.278E+00	2.231E-01	0.	2.231E-01
5614400	BA	.417	.449	.443	.647	2.079E-02	3.397E-02	5.436E-02	7.168E+07	4.209E-05	2.753E-01	4.445E-01	7.198E-01
5714400	LA	1.535	1.954	1.745	1.071	7.648E-02	9.805E-02	1.745E-01	1.131E+08	2.415E-04	1.013E+00	1.298E+00	2.311E+00
5714500	LA	.727	1.037	.492	.690	3.623E-02	5.202E-02	8.825E-02	7.647E+07	1.184E-04	4.797E-01	6.889E-01	1.169E+00
5814500	CF	.484	.572	.428	.773	2.414E-02	2.870E-02	5.284E-02	8.560E+07	9.047E-04	3.196E-01	3.800E-01	6.996E-01
5914500	PR	.543	.011	.276	.774	3.704E-02	5.288E-04	2.757E-02	8.572E+07	9.851E-02	3.580E-01	7.002E-03	3.650E-01
5714600	LA	.626	.829	.727	.366	3.118E-02	4.198E-02	7.276E-02	3.940E+07	1.746E-05	4.129E-01	5.506E-01	9.635E-01
5814600	CE	.144	.195	.155	.598	7.195E-03	9.318E-03	1.651E-02	6.623E+07	3.012E-03	9.528E-02	1.234E-01	2.187E-01
5914600	PR	.554	.970	.753	.670	2.762E-02	4.867E-02	7.629E-02	6.650E+07	5.154E-03	3.658E-01	6.445E-01	1.010E+00
5814700	CE	.371	.550	.441	.438	1.849E-02	2.762E-02	4.611E-02	4.852E+07	1.813E-04	2.449E-01	3.657E-01	6.106E-01
5914800	PR	.704	.103	.422	.346	3.510E-02	5.153E-03	4.025E-02	3.837E+07	2.458E-04	4.648E-01	6.823E-02	5.330E-01

TABLE B-IV

TMT, UNIT 2, 22-STEP POWER HISTORY, FULL CORE CALC., CINDER-10(LASL) 7779

25=TIME STEP
 1.00000F+01=TOTAL TIME SINCE LAST TIME AT POWER(S)
 2.93379E+07=TOTAL ELAPSED TIME(S)
 8.26531E+19=FISSIONS/S AT LAST TS AT POWER (22)
 2.69970E+09=POWER (WATTS) AT LAST TS AT POWER (2.69970E+03 MW)
 6.95228E+02=ACCUMULATED FISSIONS (FISSIONS PER BARN-CM)
 1.39000E+03=TOTAL FP IN SUM PER BARN-CM

3.80462E+20=TOTAL ACTIVITY (DTS/S)
 1.02827E+10=TOTAL CURIES
 5.75910E+01=TOTAL BETA DECAY POWER (MW)
 6.04074E+01=TOTAL GAMMA DECAY POWER (MW)
 1.17998E+02=TOTAL DECAY POWER (MW)
 4.34924E+00=TOTAL BETA MEV/F
 4.56194E+00=TOTAL GAMMA MEV/F
 8.91119E+00=TOTAL DECAY MEV/F

ID	SYM	PERCENT OF		ALL FP		MEV/FISS			DECAY POWER IN MW				
		BETA	GAMMA	TOTAL	CURIES	BETA	GAMMA	TOTAL	CURIES	DENSITY	BETA	GAMMA	TOTAL
3508600	BR	.330	.498	.462	.176	1.435E-02	2.683E-02	4.118E-02	1.806E+07	5.303E-05	1.901E-01	3.592E-01	5.453E-01
3508700	BR	.892	.498	.797	.395	3.881E-02	3.137E-02	7.017E-02	4.059E+07	1.209E-04	5.138E-01	4.154E-01	9.292E-01
3608700	KR	.704	.399	.548	.498	3.062E-02	1.818E-02	4.880E-02	5.123E+07	1.248E-02	4.054E-01	2.408E-01	6.462E-01
3508800	BP	1.050	.614	.827	.324	4.569E-02	2.802E-02	7.371E-02	3.327E+07	2.824E-05	6.050E-01	3.710E-01	9.760E-01
3608900	KR	.186	1.577	.878	.707	8.086E-03	7.195E-02	8.004E-02	7.267E+07	3.910E-02	1.071E-01	9.528E-01	1.060E+00
3708800	RB	1.573	.495	1.016	.714	6.843E-02	2.214E-02	9.058E-02	7.340E+07	4.161E-03	9.062E-01	2.932E-01	1.199E+00
3608900	KR	1.164	1.844	1.512	.886	5.061E-02	8.413E-02	1.347E-01	9.109E+07	9.219E-04	6.702E-01	1.114E+00	1.784E+00
3708900	RB	.933	2.191	1.577	.949	4.058E-02	9.995E-02	1.405E-01	9.754E+07	4.749E-03	5.373E-01	1.323E+00	1.861E+00
3808900	SR	.376	0.000	.194	.611	1.636E-02	0.	1.636E-02	6.279E+07	1.506E+01	2.166E-01	0.	2.166E-01
3609000	KR	.950	1.334	1.147	.755	4.131E-02	6.087E-02	1.022E-01	7.773E+07	1.340E-04	5.470E-01	8.060E-01	1.353E+00
3709000	RB	1.608	2.497	2.044	.914	6.994E-02	1.122E-01	1.821E-01	9.420E+07	8.146E-04	9.261E-01	1.485E+00	2.412E+00
3709010	RB	.273	.890	.569	.233	1.187E-02	3.880E-02	5.067E-02	2.397E+07	3.286E-04	1.572E-01	5.137E-01	6.709E-01
3609100	KR	.860	.730	.538	.315	3.742E-02	1.050E-02	4.792E-02	3.242E+07	1.506E-05	4.954E-01	1.391E-01	6.345E-01
3709100	RB	1.500	2.929	2.232	1.062	6.524E-02	1.336E-01	1.989E-01	1.092E+08	3.393E-04	8.638E-01	1.770E+00	2.633E+00
3809100	SR	.811	.824	.818	1.175	3.527E-02	3.760E-02	7.287E-02	1.208E+08	2.201E-01	4.679E-01	4.979E-01	9.650E-01
3909100	Y	.456	.002	.223	.710	1.982E-02	8.698E-05	1.990E-02	7.305E+07	1.974E+01	2.624E-01	1.152E-03	2.636E-01
3909110	Y	0.000	.379	.124	.677	0.	1.729E-02	1.729E-02	6.959E+07	1.108E-02	0.	2.290E-01	2.290E-01
3709200	RB	.916	.046	.491	.250	3.983E-02	3.010E-03	4.284E-02	2.572E+07	6.220E-06	5.275E-01	3.985E-02	5.673E-01

5714000	LA	.671	2.944	1.783	1.225	2.917E-02	1.298E-01	1.599E-01	1.260E+08	9.743E-01	3.862E-01	1.718E+00	2.104E+00
5514100	CS	1.058	1.317	1.271	.726	4.602E-02	6.099E-02	1.070E-01	7.466E+07	9.964E-05	6.094E-01	8.077E-01	1.417E+00
5614100	BA	1.209	1.119	1.143	1.248	9.260E-02	5.101E-02	1.036E-01	1.283E+08	7.522E-03	6.965E-01	6.755E-01	1.372E+00
5714100	LA	1.315	.042	.643	1.255	5.720E-02	1.896E-03	5.909E-02	1.291E+08	9.599E-02	7.574E-01	2.510E-02	7.829E-01
5814100	CE	.159	.049	.113	.945	6.934E-03	3.118E-03	1.005E-02	9.715E+07	1.458E+01	9.185E-02	4.129E-02	1.331E-01
5614200	BA	.554	1.249	.910	1.222	2.409E-02	5.696E-02	8.103E-02	1.256E+08	4.306E-03	3.190E-01	7.543E-01	1.073E+00
5714200	LA	1.259	2.042	2.172	1.294	5.476E-02	1.388E-01	1.935E-01	1.292E+08	3.822E-02	7.251E-01	1.838E+00	2.563E+00
5614300	BA	.800	1.107	.744	.694	3.480E-02	5.017E-02	8.497E-02	7.139E+07	5.183E-05	4.608E-01	6.644E-01	1.129E+00
5714300	LA	1.087	1.422	1.258	1.235	4.727E-02	6.487E-02	1.121E-01	1.270E+08	5.695E-03	6.259E-01	8.589E-01	1.485E+00
5814300	CE	.552	.371	.459	1.244	2.400E-02	1.694E-02	4.094E-02	1.279E+08	8.112E-01	3.178E-01	2.243E-01	5.421E-01
5914300	PR	.387	0.000	.199	1.130	1.685E-02	0.	1.685E-02	1.162E+08	7.278E+00	2.231E-01	0.	2.231E-01
5614400	BA	.328	.505	.418	.479	1.425E-02	2.302E-02	3.727E-02	4.915E+07	2.886E-05	1.888E-01	3.048E-01	4.936E-01
5714400	LA	1.676	2.042	1.857	1.049	7.290E-02	9.346E-02	1.664E-01	1.078E+08	2.302E-04	9.654E-01	1.238E+00	2.203E+00
5714500	LA	.752	1.029	.834	.671	3.269E-02	4.695E-02	7.964E-02	6.902E+07	1.068E-04	4.329E-01	6.217E-01	1.055E+00
5814500	CF	.553	.427	.431	.430	2.406E-02	2.861E-02	5.267E-02	8.533E+07	9.019E-04	3.186E-01	3.788E-01	6.975E-01
5914500	PR	.522	.012	.309	.834	2.704E-02	5.288E-04	2.757E-02	8.572E+07	9.851E-02	3.580E-01	7.002E-03	3.650E-01
5714600	LA	.448	.570	.411	.240	1.950E-02	2.600E-02	4.550E-02	2.464E+07	1.092E-05	2.582E-01	3.443E-01	6.025E-01
5814600	CE	.165	.204	.195	.442	7.177E-03	9.295E-03	1.647E-02	6.606E+07	3.004E-03	9.504E-02	1.231E-01	2.181E-01
5914600	PR	.635	1.067	.856	.647	2.762E-02	4.867E-02	7.629E-02	6.650E+07	5.154E-03	3.658E-01	6.445E-01	1.010E+00
5814700	CE	.409	.582	.437	.454	1.778E-02	2.655E-02	4.432E-02	4.665E+07	1.743E-04	2.354E-01	3.515E-01	5.869E-01
5914800	PR	.802	.112	.449	.371	3.488E-02	5.121E-03	4.001E-02	3.813E+07	2.443E-04	4.619E-01	6.781E-02	5.297E-01

TABLE B-V

TMI, UNIT 2, 22-STEP POWER HISTORY, FULL CORE CALC., CINDER-10(LASL) 7/79

26=TIME STEP
 4.00000E+01=TOTAL TIME SINCE LAST TIME AT POWER(S)
 2.93379E+07=TOTAL ELAPSED TIME(S)
 8.26531E+19=FISSIONS/S AT LAST TS AT POWER (22)
 2.69970E+09=POWER (WATTS) AT LAST TS AT POWER (2.69970E+03 MW)
 6.95228E+02=ACCUMULATED FISSIONS (FISSIONS PER BARN-CM)
 1.39000E+03=TOTAL FP IN SUM PER BARN-CM

3.25417E+20=TOTAL ACTIVITY (NTS/S)
 8.79505E+09=TOTAL CURIES
 4.37310E+01=TOTAL BETA DECAY POWER (MW)
 4.91883E+01=TOTAL GAMMA DECAY POWER (MW)
 9.29193E+01=TOTAL DECAY POWER (MW)
 3.30255E+00=TOTAL BETA MFV/F
 3.71468E+00=TOTAL GAMMA MFV/F
 7.01722E+00=TOTAL DECAY MFV/F

ID ZAAAS	SYM	-----PERCENT OF		ALL FP-----		-----MFV/FISS-----			CURIES	DENSITY	---DECAY POWER IN MW---		
		BETA	GAMMA	TOTAL	CURTIES	BETA	GAMMA	TOTAL			BETA	GAMMA	TOTAL
3504600	BR	.334	.554	.450	.158	1.102E-02	2.059E-02	3.161E-02	1.387E+07	4.071E-05	1.459E-01	2.727E-01	4.186E-01
3508700	BR	.822	.491	.700	.323	2.716E-02	2.195E-02	4.911E-02	2.841E+07	8.462E-05	3.596E-01	2.907E-01	6.504E-01
3608700	KR	.926	.499	.494	.582	3.057E-02	1.816E-02	4.873E-02	5.117E+07	1.246E-02	4.048E-01	2.404E-01	6.452E-01
3608800	KR	.244	1.934	1.139	.828	8.074E-03	7.184E-02	7.992E-02	7.256E+07	3.904E-02	1.069E-01	9.513E-01	1.058E+00
3708800	RR	2.072	.596	1.271	.834	5.842E-02	2.214E-02	9.056E-02	7.339E+07	4.160E-03	9.060E-01	2.932E-01	1.199E+00
3608900	KR	1.376	2.034	1.224	.930	4.546E-02	7.555E-02	1.210E-01	8.181E+07	8.280E-04	6.019E-01	1.000E+00	1.602E+00
3708900	RB	1.226	2.884	1.937	1.106	4.048E-02	9.969E-02	1.402E-01	9.729E+07	4.736E-03	5.360E-01	1.320E+00	1.856E+00
3808900	SR	.495	0.000	.233	.714	1.636E-02	0.	1.636E-02	6.279E+07	1.506E+01	2.166E-01	0.	2.166E-01
3609000	KR	.657	.861	.745	.464	2.170E-02	3.198E-02	5.368E-02	4.084E+07	7.042E-05	2.874E-01	4.235E-01	7.109E-01
3709000	RB	1.995	2.845	2.445	1.009	6.590E-02	1.057E-01	1.716E-01	8.875E+07	7.675E-04	8.726E-01	1.400E+00	2.272E+00

5614100	BA	1.575	1.359	1.447	1.443	5.700E-02	5.043E-02	1.024E-01	1.269E+08	7.437E-03	6.886E-01	6.678E-01	1.356E+00
5714100	LA	1.732	.051	.842	1.448	5.719E-02	1.896E-03	5.909E-02	1.291E+08	9.599E-02	7.573E-01	2.510E-02	7.824E-01
5814100	CE	.210	.084	.743	1.105	6.936E-03	3.118E-03	1.005E-02	9.715E+07	1.458E+01	9.185E-02	4.129E-02	1.331E-01
5614200	BA	.706	1.485	1.118	1.393	2.332E-02	5.515E-02	7.847E-02	1.216E+08	4.169E-03	3.088E-01	7.302E-01	1.039E+00
5714200	LA	1.658	.735	2.757	1.448	5.475E-02	1.357E-01	1.935E-01	1.291E+08	3.822E-02	7.250E-01	1.837E+00	2.562E+00
5714300	LA	1.406	1.716	1.970	1.419	4.644E-02	6.374E-02	1.102E-01	1.248E+08	5.596E-03	6.150E-01	8.440E-01	1.459E+00
5814300	CE	.727	.455	.913	1.456	2.400E-02	1.694E-02	4.094E-02	1.279E+08	8.112E-01	3.178E-01	2.243E-01	5.421E-01
5914300	PR	.510	0.700	.740	1.371	1.685E-02	0.	1.685E-02	1.162E+08	7.278E+00	2.231E-01	0.	2.231E-01
5714400	LA	1.482	1.689	1.592	.823	4.894E-02	6.274E-02	1.117E-01	7.238E+07	1.545E-04	6.481E-01	8.308E-01	1.479E+00
5714500	LA	.509	.650	.594	.404	1.681E-02	2.415E-02	4.096E-02	3.550E+07	5.495E-05	2.227E-01	3.197E-01	5.424E-01
5814500	CE	.699	.739	.770	.931	2.309E-02	2.745E-02	5.054E-02	8.188E+07	8.654E-04	3.057E-01	3.635E-01	6.692E-01
5914500	PR	.819	.014	.373	.975	2.704E-02	5.288E-04	2.757E-02	8.572E+07	9.850E-02	3.580E-01	7.002E-03	3.650E-01
5814600	CE	.213	.245	.230	.735	7.028E-03	9.101E-03	1.613E-02	6.469E+07	2.942E-03	9.306E-02	1.205E-01	2.136E-01
5914600	PR	.836	1.319	1.097	.756	2.762E-02	4.866E-02	7.629E-02	6.649E+07	5.153E-03	3.657E-01	6.443E-01	1.010E+00
5814700	CE	.415	.952	.497	.499	1.372E-02	2.049E-02	3.421E-02	3.600E+07	1.345E-04	1.817E-01	2.713E-01	4.529E-01
5914700	PR	.912	.499	.979	.974	1.692E-02	1.855E-02	3.546E-02	5.052E+07	1.942E-03	2.240E-01	2.456E-01	4.696E-01
6014700	ND	.156	.069	.110	.543	5.167E-03	2.537E-03	7.704E-03	4.775E+07	2.420E+00	6.841E-02	3.360E-02	1.020E-01
5914800	PR	.992	.130	.536	.407	3.277E-02	4.812E-03	3.759E-02	3.583E+07	2.295E-04	4.340E-01	6.371E-02	4.977E-01

TABLE B-VI

TMT, UNIT 2, 22-STEP POWER HISTORY, FULL CORE CALC., CINDER-10(LASL) 7/79

27=TIME STEP
 1.00000E+02=TOTAL TIME SINCE LAST TIME AT POWER(S)
 2.93379E+07=TOTAL ELAPSED TIME(S)
 8.26531E+19=FISSIONS/S AT LAST TS AT POWER.(22)
 2.69970E+09=POWER (WATTS) AT LAST TS AT POWER (2.69970E+03 MW)
 6.95228E+02=ACCUMULATED FISSIONS (FISSIONS PER BARN-CM)
 1.39000E+03=TOTAL FP IN SUM PER BARN-CM

2.97982E+20=TOTAL ACTIVITY (DYS/S)
 7.78331E+09=TOTAL CURIES
 3.52229E+01=TOTAL BETA DECAY POWER (MW)
 4.11672E+01=TOTAL GAMMA DECAY POWER (MW)
 7.63901E+01=TOTAL DECAY POWER (MW)
 2.66002E+00=TOTAL BETA MEV/F
 3.10892E+00=TOTAL GAMMA MEV/F
 5.76894E+00=TOTAL DECAY MEV/F

ID	SYM	PERCENT OF ALL FP				MEV/FISS			CURIES	DENSITY	DECAY POWER IN MW		
		BETA	GAMMA	TOTAL	CURIES	BETA	GAMMA	TOTAL					
3508400	BR	.436	.521	.492	.265	1.160E-02	1.619E-02	2.780E-02	2.064E+07	2.102E-03	1.536E-01	2.144E-01	3.681E-01
3608700	KR	1.143	.591	.840	.654	3.040E-02	1.806E-02	4.846E-02	5.089E+07	1.239E-02	4.026E-01	2.391E-01	6.417E-01
3608800	KR	.302	2.392	1.390	.729	8.042E-03	7.156E-02	7.960E-02	7.227E+07	3.889E-02	1.065E-01	9.475E-01	1.054E+00
3708800	RR	2.571	.712	1.559	.942	6.838E-02	2.213E-02	9.051E-02	7.335E+07	4.158E-03	9.055E-01	2.930E-01	1.199E+00
3608900	KR	1.372	1.952	1.495	.844	3.650E-02	6.067E-02	9.718E-02	6.570E+07	6.649E-04	4.834E-01	8.034E-01	1.287E+00
3708900	RR	1.505	3.171	2.493	1.234	4.003E-02	9.860E-02	1.396E-01	9.623E+07	4.684E-03	5.301E-01	1.306E+00	1.836E+00
3808900	SP	.615	0.070	.794	.807	1.636E-02	0.	1.636E-02	6.279E+07	1.506E+01	2.166E-01	0.	2.166E-01
3709000	RB	2.042	2.802	2.452	.940	5.431E-02	8.712E-02	1.414E-01	7.315E+07	6.326E-04	7.192E-01	1.154E+00	1.873E+00
3709010	RR	.371	1.079	.730	.245	9.869E-03	3.228E-02	4.212E-02	1.993E+07	2.732E-04	1.307E-01	4.271E-01	5.578E-01
3709100	RB	.983	1.549	1.242	.575	2.350E-02	4.814E-02	7.163E-02	3.934E+07	1.222E-04	3.111E-01	6.374E-01	9.485E-01
3809100	SR	1.325	1.209	1.262	1.551	3.524E-02	3.757E-02	7.282E-02	1.207E+08	2.199E-01	4.667E-01	4.975E-01	9.642E-01

5914300	PR	.634	0.000	.232	1.493	1.685E-02	0.	1.685E-02	1.162E+08	7.278E+00	2.231E-01	0.	2.231E-01
5714400	LA	.674	.739	.779	.741	1.793E-02	2.299E-02	4.092E-02	2.652E+07	5.663E-05	2.375E-01	3.044E-01	5.419E-01
5914400	PR	.520	.011	.246	.315	1.384E-02	3.399E-04	1.418E-02	2.449E+07	1.355E-03	1.833E-01	4.501E-03	1.878E-01
5814500	CE	.741	.753	.747	.998	1.970E-02	2.342E-02	4.312E-02	6.986E+07	7.384E-04	2.609E-01	3.101E-01	5.710E-01
5914500	PR	1.016	.017	.478	1.191	7.703E-02	5.297E-04	7.756E-02	8.570E+07	9.848E-02	3.580E-01	7.000E-03	3.650E-01
5814600	CE	.252	.279	.256	.792	6.695E-03	8.670E-03	1.537E-02	6.162E+07	2.803E-03	8.865E-02	1.148E-01	2.035E-01
5914600	PR	1.037	1.543	1.320	.853	7.758E-02	4.859E-02	7.617E-02	6.639E+07	5.146E-03	3.652E-01	6.434E-01	1.009E+00
5914700	PR	.619	.591	.539	.632	1.648E-02	1.807E-02	3.454E-02	4.921E+07	1.891E-03	2.182E-01	2.392E-01	4.574E-01
6014700	ND	.194	.082	.134	.614	5.167E-03	2.537E-03	7.704E-03	4.775E+07	2.420E+00	6.841E-02	3.360E-02	1.020E-01
5914800	PR	.988	.124	.522	.353	2.627E-02	3.856E-03	3.013E-02	2.872E+07	1.839E-04	3.478E-01	5.106E-02	3.989E-01

TABLE B-VII

TMI, UNIT 2, 22-STEP POWER HISTORY, FULL CORE CALC., CINDER-10(LASL) 7/79

2A=TIME STEP
 4.00000E+02=TOTAL TIME SINCE LAST TIME AT POWER(S)
 2.93382E+07=TOTAL ELAPSED TIME(S)
 8.26531E+19=FISSIONS/S AT LAST TS AT POWER (22)
 2.69970E+09=POWER (WATTS) AT LAST TS AT POWER (2.69970E+03 MW)
 6.95228E+02=ACCUMULATED FISSIONS (FISSIONS PER BARN-CM)
 1.39000E+03=TOTAL FP IN SIM PER BARN-CM

2.36830E+20=TOTAL ACTIVITY (DIS/S)
 6.40082E+09=TOTAL CURIES
 2.49410E+01=TOTAL BETA DECAY POWER (MW)
 3.10814E+01=TOTAL GAMMA DECAY POWER (MW)
 5.60224E+01=TOTAL DECAY POWER (MW)
 1.88353E+00=TOTAL BETA MFV/F
 2.34725E+00=TOTAL GAMMA MFV/F
 4.23079E+00=TOTAL DECAY MFV/F

ID	SYM	PERCENT OF ALL FP			MEV/FISS			CURIES	DENSITY	DECAY POWER IN MW			
		BETA	GAMMA	TOTAL	BETA	GAMMA	TOTAL			BETA	GAMMA	TOTAL	
3508400	RR	.580	.649	.618	.703	1.092E-02	1.524E-02	2.616E-02	1.942E+07	1.978E-03	1.446E-01	2.018E-01	3.464E-01
3608700	KR	1.547	.737	1.098	.762	2.914E-02	1.731E-02	4.645E-02	4.878E+07	1.187E-02	3.859E-01	2.292E-01	6.150E-01
3608800	KR	.418	2.986	1.843	1.106	7.878E-03	7.010E-02	7.799E-02	7.080E+07	3.809E-02	1.043E-01	9.282E-01	1.033E+00
3708800	RB	3.614	.939	2.130	1.141	5.808E-02	2.203E-02	9.011E-02	7.302E+07	4.140E-03	9.015E-01	2.917E-01	1.193E+00
3608900	KR	.647	.863	.767	.343	1.219E-02	2.026E-02	3.245E-02	2.194E+07	2.221E-04	1.614E-01	2.683E-01	4.297E-01
3708900	RB	1.868	3.602	2.890	1.321	3.519E-02	8.666E-02	1.218E-01	8.458E+07	4.117E-03	4.659E-01	1.148E+00	1.613E+00
3808900	SR	.869	0.000	.397	.981	1.636E-02	0.	1.636E-02	6.279E+07	1.506E+01	2.166E-01	0.	2.166E-01
3709000	RB	.843	1.084	.977	.334	1.587E-02	2.545E-02	4.132E-02	2.137E+07	1.848E-04	2.101E-01	3.371E-01	5.472E-01
3709010	RB	.236	.619	.449	.140	4.447E-03	1.454E-02	1.898E-02	8.980E+06	1.231E-04	5.889E-02	1.925E-01	2.514E-01
3809100	SR	1.861	1.592	1.712	1.875	3.505E-02	3.737E-02	7.241E-02	1.200E+08	2.187E-01	4.641E-01	4.948E-01	9.589E-01
3909100	Y	1.052	.004	.470	1.141	1.982E-02	8.699E-03	1.990E-02	7.305E+07	1.974E+01	2.624E-01	1.152E-03	2.636E-01
3909110	Y	0.000	.737	.499	1.097	0.	1.729E-02	1.729E-02	6.957E+07	1.107E-02	0.	2.289E-01	2.289E-01
3809200	SR	.546	3.049	1.935	1.866	1.028E-02	7.157E-02	8.185E-02	1.194E+08	6.219E-02	1.361E-01	9.477E-01	1.084E+00
3909200	Y	4.281	.582	2.229	1.922	9.064E-02	1.367E-02	9.431E-02	1.230E+08	8.346E-02	1.068E+00	1.810E-01	1.249E+00
3809300	SR	1.974	1.903	1.935	1.118	3.719E-02	4.468E-02	8.187E-02	7.155E+07	1.719E-03	4.924E-01	5.916E-01	1.084E+00
3909300	Y	3.762	.229	1.871	2.994	7.085E-02	5.358E-03	7.621E-02	1.336E+08	2.619E-01	9.382E-01	7.095E-02	1.009E+00
3909400	Y	4.626	2.122	3.242	1.771	9.714E-02	5.003E-02	1.372E-01	1.133E+08	6.897E-03	1.154E+00	6.625E-01	1.816E+00
3909500	Y	3.820	.857	2.176	1.438	7.195E-02	2.013E-02	9.207E-02	9.207E+07	3.096E-03	9.527E-01	2.665E-01	1.219E+00
4009500	ZR	.218	1.108	.712	1.233	4.107E-03	2.600E-02	3.010E-02	7.889E+07	2.383E+01	5.438E-02	3.442E-01	3.986E-01

TABLE B-VIII

TMT, UNIT 2, 22-STEP POWER HISTORY, FULL CORE CALC., CINDER-10(LASL) 7/79

29=TIME STEP
 1.00000E+03=TOTAL TIME SINCE LAST TIME AT POWER(S)
 2.93389E+07=TOTAL ELAPSED TIME(S)
 8.26531E+19=FISSIONS/S AT LAST TS AT POWER, (22)
 2.69970E+09=POWER (WATTS) AT LAST TS AT POWER (2.69970E+03 MW)
 6.95229E+02=ACCUMULATED FISSIONS (FISSIONS PER BARN-CM)
 1.39000E+03=TOTAL FP IN SIM PER BARN-CM

2.04110E+20=TOTAL ACTIVITY (DTS/S)
 5.51649E+09=TOTAL CURIES
 1.94709E+01=TOTAL BETA DECAY POWER (MW)
 2.55977E+01=TOTAL GAMMA DECAY POWER (MW)
 4.50685E+01=TOTAL DECAY POWER (MW)
 1.47043E+00=TOTAL BETA MEV/F
 1.93313E+00=TOTAL GAMMA MEV/F
 3.40356E+00=TOTAL DECAY MEV/F

ID ZZAAAS	SYM	-----PERCENT OF		ALL FP-----		-----MEV/FISS-----			CURIES	DENSITY	---DECAY POWER IN MW---		
		BETA	GAMMA	TOTAL	CURIES	BETA	GAMMA	TOTAL			BETA	GAMMA	TOTAL
3508400	BR	.612	.650	.634	.290	9.005E-03	1.257E-02	2.157E-02	1.602E+07	1.632E-03	1.192E-01	1.664E-01	2.857E-01
3608700	KR	1.809	.817	1.246	.807	2.660E-02	1.580E-02	4.240E-02	4.453E+07	1.084E-02	3.523E-01	2.092E-01	5.615E-01
3608800	KR	.514	3.480	2.178	1.232	7.560E-03	6.727E-02	7.482E-02	6.794E+07	3.655E-02	1.001E-01	8.907E-01	9.908E-01
3708800	RB	4.553	1.121	2.673	1.377	6.694E-02	2.166E-02	8.860E-02	7.180E+07	4.071E-03	8.864E-01	2.868E-01	1.173E+00
3708900	RB	1.602	3.001	2.376	1.076	2.355E-02	5.801E-02	8.156E-02	5.661E+07	2.756E-03	3.119E-01	7.681E-01	1.080E+00
3804900	SR	1.113	0.000	.491	1.138	1.636E-02	0.	1.636E-02	6.279E+07	1.506E+01	2.166E-01	0.	2.166E-01
3809100	SR	2.355	1.910	2.177	2.150	3.462E-02	3.691E-02	7.154E-02	1.186E+08	2.160E-01	4.585E-01	4.888E-01	9.473E-01
3909100	Y	1.348	.005	.995	1.374	1.982E-02	8.699E-05	1.991E-02	7.306E+07	1.974E+01	2.624E-01	1.152E-03	2.636E-01
3909110	Y	0.000	.893	.907	1.259	0.	1.726E-02	1.726E-02	6.944E+07	1.105E-02	0.	2.285E-01	2.285E-01
3809200	SR	.670	3.548	2.325	2.074	9.851E-03	6.859E-02	7.844E-02	1.144E+08	5.959E-02	1.304E-01	9.082E-01	1.039E+00
3909200	Y	5.475	.706	2.767	2.727	8.051E-02	1.365E-02	9.416E-02	1.228E+08	8.332E-02	1.066E+00	1.807E-01	1.247E+00
3809300	SR	1.004	.917	.959	.515	1.476E-02	1.773E-02	3.249E-02	2.839E+07	6.820E-04	1.954E-01	2.348E-01	4.302E-01
3909300	Y	4.783	.275	2.273	2.405	7.034E-02	5.319E-03	7.566E-02	1.327E+08	2.600E-01	9.314E-01	7.043E-02	1.002E+00
3909400	Y	4.123	1.801	2.974	1.429	5.063E-02	3.481E-02	9.544E-02	7.886E+07	4.799E-03	8.028E-01	4.610E-01	1.264E+00
3909500	Y	2.529	.439	1.398	.862	3.718E-02	1.040E-02	4.758E-02	4.758E+07	1.600E-03	4.923E-01	1.377E-01	6.301E-01
4009500	ZR	.279	1.345	.894	1.430	4.107E-03	2.600E-02	3.010E-02	7.889E+07	2.383E+01	5.438E-02	3.442E-01	3.986E-01
4109500	NR	.068	.911	.947	.931	1.002E-03	1.761E-02	1.862E-02	5.138E+07	8.317E+00	1.327E-02	2.332E-01	2.465E-01
4009700	ZR	2.789	.945	1.515	2.349	4.102E-02	1.054E-02	5.156E-02	1.296E+08	4.183E-01	5.431E-01	1.396E-01	6.827E-01
4109700	NR	1.872	2.061	1.979	2.383	2.753E-02	3.984E-02	6.737E-02	1.314E+08	3.098E-02	3.646E-01	5.275E-01	8.921E-01
4109710	NR	0.000	1.923	1.072	2.077	0.	3.717E-02	3.717E-02	1.118E+08	3.223E-04	0.	4.922E-01	4.922E-01
4209900	MD	1.599	.588	1.025	2.474	2.351E-02	1.137E-02	3.488E-02	1.365E+08	1.732E+00	3.113E-01	1.505E-01	4.618E-01
4309910	TC	0.000	.390	.222	2.141	0.	7.546E-03	7.546E-03	1.181E+08	1.366E-01	0.	9.993E-02	9.993E-02
4210100	MD	.971	1.720	1.376	.971	1.427E-02	3.325E-02	4.752E-02	5.359E+07	2.506E-03	1.890E-01	4.403E-01	6.293E-01
4310100	TC	1.388	.740	1.070	1.722	2.041E-02	1.430E-02	3.470E-02	9.498E+07	4.320E-03	2.702E-01	1.893E-01	4.595E-01
4210200	MD	.348	0.000	.151	.667	5.124E-03	0.	5.124E-03	3.679E+07	1.308E-03	6.784E-02	0.	6.784E-02
4310200	TC	1.703	.398	.967	.672	2.505E-02	7.699E-03	3.275E-02	3.708E+07	1.049E-05	3.317E-01	1.019E-01	4.336E-01
4410300	RU	.119	.456	.424	1.048	1.747E-03	1.268E-02	1.443E-02	5.780E+07	1.056E+01	2.314E-02	1.679E-01	1.910E-01
4510310	RH	0.000	.053	.030	1.048	0.	1.029E-03	1.029E-03	5.779E+07	1.036E-02	0.	1.363E-02	1.363E-02
4310400	TC	1.176	1.085	1.124	.597	1.729E-02	2.098E-02	3.827E-02	3.237E+07	1.866E-03	2.289E-01	2.778E-01	5.067E-01
4410500	RU	.474	.489	.576	.685	4.795E-03	1.331E-02	2.029E-02	3.776E+07	3.222E-02	9.236E-02	1.763E-01	2.687E-01
4510500	RH	.170	.067	.111	.645	2.501E-03	1.294E-03	3.795E-03	3.669E+07	2.503E-01	3.312E-02	1.713E-02	5.025E-02
5113010	SR	.703	1.488	1.149	.883	1.034E-02	2.876E-02	3.910E-02	2.113E+07	2.504E-03	1.369E-01	3.808E-01	5.177E-01
5113100	SB	.778	1.411	1.137	.649	1.144E-02	2.728E-02	3.872E-02	3.579E+07	2.637E-03	1.514E-01	3.612E-01	5.127E-01

5213100	TF	1.092	.523	.758	.968	1.605E-02	1.010E-02	2.616E-02	5.338E+07	4.274E-03	2.126E-01	1.338E-01	3.464E-01
5313100	I	.361	.576	.443	1.159	5.309E-03	1.114E-02	1.645E-02	6.394E+07	2.371E+00	7.031E-02	1.475E-01	2.178E-01
5213200	TF	.178	.606	.421	1.765	2.617E-03	1.171E-02	1.432E-02	9.735E+07	1.459E+00	3.465E-02	1.550E-01	1.897E-01
5313200	I	1.568	5.086	3.564	1.779	2.306E-02	9.833E-02	1.214E-01	9.816E+07	4.310E-02	3.053E-01	1.302E+00	1.607E+00
5213300	TF	1.501	.995	1.034	.792	1.604E-02	1.923E-02	3.527E-02	4.369E+07	1.749E-03	2.124E-01	2.546E-01	4.670E-01
5213310	TE	.866	2.229	1.640	.734	1.274E-02	4.306E-02	5.580E-02	5.155E+07	9.147E-03	1.687E-01	5.702E-01	7.389E-01
5313300	I	1.918	2.095	2.719	2.739	2.821E-02	4.049E-02	6.870E-02	1.510E+08	6.037E-01	3.735E-01	5.362E-01	9.097E-01
5413300	XE	.464	.282	.351	2.714	6.828E-03	5.458E-03	1.227E-02	1.497E+08	3.653E+00	9.042E-02	7.228E-02	1.627E-01
5213400	TF	.508	2.095	1.479	1.999	7.466E-03	4.050E-02	4.797E-02	1.097E+08	1.475E-02	9.886E-02	5.363E-01	6.352E-01
5313400	I	3.380	9.647	6.960	2.913	4.970E-02	1.865E-01	2.367E-01	1.607E+08	2.707E-02	6.581E-01	2.469E+00	3.128E+00
5313500	I	1.651	4.644	3.351	2.497	2.427E-02	8.977E-02	1.140E-01	1.377E+08	1.743E-01	3.214E-01	1.189E+00	1.510E+00
5413500	XE	.332	.213	.254	.639	4.882E-03	4.119E-03	9.001E-03	3.519E+07	6.201E-02	6.465E-02	5.454E-02	1.192E-01
5413800	XE	1.214	1.479	1.479	1.999	1.785E-02	3.244E-02	5.023E-02	6.063E+07	2.758E-03	2.364E-01	4.295E-01	6.659E-01
5513800	CS	4.908	6.887	6.032	2.315	7.216E-02	1.331E-01	2.053E-01	1.277E+08	1.317E-02	9.556E-01	1.763E+00	2.719E+00
5513900	CS	2.307	.309	1.172	.779	3.393E-02	5.978E-03	3.990E-02	4.297E+07	1.280E-03	4.492E-01	7.915E-02	5.284E-01
5613900	BA	3.678	.163	1.692	2.441	5.408E-02	3.152E-03	5.723E-02	1.346E+08	3.592E-02	7.161E-01	4.173E-02	7.579E-01
5614000	BA	1.383	.637	.830	2.331	1.593E-02	1.232E-02	2.825E-02	1.269E+08	7.488E+00	2.107E-01	1.632E-01	3.741E-01
5714000	LA	1.984	6.713	4.670	2.298	2.917E-02	1.298E-01	1.589E-01	1.260E+08	9.744E-01	3.862E-01	1.718E+00	2.105E+00
5614100	BA	1.941	1.432	1.452	1.242	2.854E-02	2.767E-02	5.621E-02	6.963E+07	4.081E-03	3.779E-01	3.665E-01	7.443E-01
5714100	LA	3.942	.097	1.715	2.311	5.650E-02	1.873E-03	5.837E-02	1.275E+08	9.482E-02	7.481E-01	2.480E-02	7.729E-01
5814100	CE	.472	.161	.235	1.761	6.937E-03	3.119E-03	1.006E-02	9.716E+07	1.458E+01	9.186E-02	4.129E-02	1.331E-01
5614200	BA	.563	1.012	.814	.792	4.272E-03	1.195E-02	1.603E-02	4.315E+07	1.479E-03	1.095E-01	2.590E-01	3.686E-01
5714200	LA	3.547	6.837	5.415	2.230	5.215E-02	1.322E-01	1.843E-01	1.230E+08	3.640E-02	6.906E-01	1.750E+00	2.441E+00
5714300	LA	1.433	1.496	1.449	1.027	2.108E-02	2.892E-02	5.000E-02	5.663E+07	2.539E-03	2.791E-01	3.830E-01	6.620E-01
5814300	CE	1.629	.875	1.211	2.315	2.396E-02	1.691E-02	4.087E-02	1.277E+08	8.097E-01	3.172E-01	2.239E-01	5.411E-01
5914300	PR	1.146	0.000	.435	2.107	1.685E-02	0.	1.685E-02	1.162E+08	7.279E+00	2.231E-01	0.	2.231E-01
5914400	PR	.930	.017	.412	.479	1.368E-02	3.359E-04	1.402E-02	2.420E+07	1.339E-03	1.811E-01	4.449E-03	1.856E-01
5914500	PR	1.799	.027	.792	1.520	2.645E-02	5.173E-04	2.697E-02	8.387E+07	9.637E-02	3.503E-01	6.850E-03	3.571E-01
5814600	CE	.219	.216	.217	.537	3.219E-03	4.169E-03	7.388E-03	2.963E+07	1.348E-03	4.263E-02	5.521E-02	9.783E-02
5914600	PR	1.640	2.199	1.957	1.053	2.412E-02	4.250E-02	6.662E-02	5.807E+07	4.501E-03	3.194E-01	5.628E-01	8.822E-01
6014700	ND	.351	.131	.226	.865	5.166E-03	2.537E-03	7.703E-03	4.774E+07	2.420E+00	6.840E-02	3.359E-02	1.020E-01

TABLE B-IX

TME, UNIT %, 22-STEP POWER HISTORY, FULL CORE CALC., CINDER-10(LASL) 7/79

30=TIME STEP
3.60000E+03=TOTAL TIME SINCE LAST TIME AT POWER(S)
2.93414E+07=TOTAL ELAPSED TIME(S)
8.26531E+19=FISSIONS/S AT LAST TS AT POWER, (22)
2.69970E+04=POWER (WATTS) AT LAST TS AT POWER (2.69970E+03 MW)
6.95228E+02=ACCUMULATED FISSIONS (FISSIONS PER BARN-CM)
1.39000E+03=TOTAL FP IN SUM PER BARN-CM

1.97103E+20=TOTAL ACTIVITY (DTS/S)
4.24604E+09=TOTAL CURIES
1.28021E+01=TOTAL BETA DECAY POWER (MW)
1.72491E+01=TOTAL GAMMA DECAY POWER (MW)
3.01012E+01=TOTAL DECAY POWER (MW)
9.66806E-01=TOTAL BETA MFV/F
1.30642E+00=TOTAL GAMMA MFV/F
2.27323E+00=TOTAL DECAY MFV/F

TABLE B-X

TIME UNIT 2. 22-STEP POWER HISTORY, FULL CORE CALC., CINDFR-10(LASL) 7/79

31=TIME STEP
 7.20000E+03=TOTAL TIME SINCE LAST TIME AT POWER(S)
 2.93450E+07=TOTAL ELAPSED TIME(S)
 8.28531E+19=FISSIONS/S AT LAST TS AT POWER (22)
 2.69970E+09=POWER (WATTS) AT LAST TS AT POWER (2.69970E+03 MW)
 6.75228E+02=ACCUMULATED FISSIONS (FISSIONS PER BARN-CM)
 1.39000E+03=TOTAL FP IN SUM PER BARN-CM

1.36500E+20=TOTAL ACTIVITY (DIS/S)
 3.68918E+09=TOTAL CURIES
 1.01885E+01=TOTAL BETA DECAY POWER (MW)
 1.32290E+01=TOTAL GAMMA DECAY POWER (MW)
 2.34175E+01=TOTAL DECAY POWER (MW)
 7.69429E-01=TOTAL BETA MFV/F
 9.99050E-01=TOTAL GAMMA MFV/F
 1.76848E+00=TOTAL DECAY MFV/F

ID	SYM	PERCENT OF ALL FP				MEV/FISS			DECAY POWER IN MW				
		BETA	GAMMA	TOTAL	CURIES	BETA	GAMMA	TOTAL	CURIES	DENSITY	BETA	GAMMA	TOTAL
3608510	KR	.252	.197	.178	.519	1.938E-03	1.571E-03	3.509E-03	1.915E+07	1.649E-02	2.567E-02	2.080E-02	4.647E-02
3608700	KR	1.347	.616	.974	.479	1.037E-02	6.157E-03	1.652E-02	1.735E+07	4.224E-03	1.373E-01	8.153E-02	2.188E-01
3608800	KR	.641	4.396	2.747	1.202	4.936E-02	4.392E-02	4.885E-02	4.435E+07	2.387E-02	6.536E-02	5.815E-01	6.469E-01
3708800	RB	5.998	1.495	3.454	1.342	4.615E-02	1.494E-02	6.109E-02	4.951E+07	2.806E-03	6.111E-01	1.978E-01	8.089E-01
3808900	SR	2.125	0.000	.974	1.701	1.635E-02	0.	1.635E-02	6.274E+07	1.509E+01	2.165E-01	0.	2.165E-01
3809100	SR	3.968	3.758	3.557	2.834	3.053E-02	3.255E-02	6.307E-02	1.045E+08	1.909E-01	4.042E-01	4.310E-01	8.352E-01
3909100	Y	2.577	.009	1.126	1.991	1.983E-02	8.703E-05	1.991E-02	7.309E+07	1.975E+01	2.626E-01	1.152E-03	2.637E-01
3909110	Y	0.000	1.607	.938	1.752	0.	1.606E-02	1.606E-02	6.462E+07	1.029E-02	0.	2.126E-01	2.126E-01
3809200	SR	.824	4.419	2.855	1.997	6.341E-03	4.415E-02	5.049E-02	7.366E+07	3.836E-02	8.396E-02	5.846E-01	6.686E-01
3909200	Y	9.696	1.266	4.934	3.085	7.460E-02	1.265E-02	8.725E-02	1.138E+08	7.721E-02	9.879E-01	1.675E-01	1.155E+00
3909300	Y	8.154	.475	3.916	3.207	6.274E-02	4.744E-03	6.748E-02	1.183E+08	2.319E-01	8.307E-01	6.282E-02	8.935E-01
4009500	ZR	.533	2.600	1.771	2.137	4.104E-03	2.598E-02	3.008E-02	7.884E+07	2.382E+01	5.435E-02	3.440E-01	3.983E-01
4109500	NR	.130	1.764	1.053	1.394	1.003E-03	1.763E-02	1.863E-02	5.142E+07	8.323E+00	1.328E-02	2.334E-01	2.467E-01
4009700	ZR	4.965	.983	2.716	3.771	3.820E-02	9.819E-03	4.802E-02	1.207E+08	3.896E-01	5.059E-01	1.300E-01	6.359E-01
4109700	NB	3.460	3.856	3.694	3.445	2.662E-02	3.852E-02	6.515E-02	1.271E+08	2.996E-02	3.526E-01	5.101E-01	8.626E-01
4109710	NB	0.000	3.465	1.958	2.823	0.	3.462E-02	3.462E-02	1.041E+08	3.001E-04	0.	4.584E-01	4.584E-01
4209900	MD	3.001	1.118	1.937	3.633	2.309E-02	1.116E-02	3.425E-02	1.340E+08	1.701E+00	3.057E-01	1.478E-01	4.535E-01
4309910	TC	0.000	.754	.478	3.194	0.	7.530E-03	7.530E-03	1.178E+08	1.363E-01	0.	9.971E-02	9.971E-02
4410300	RU	.227	1.268	.815	1.555	1.745E-03	1.266E-02	1.441E-02	5.773E+07	1.054E+01	2.311E-02	1.677E-01	1.908E-01
4510310	RH	0.000	.103	.058	1.566	0.	1.029E-03	1.029E-03	5.776E+07	1.036E-02	0.	1.362E-02	1.362E-02
4410500	RU	.699	1.027	.894	.789	5.375E-03	1.026E-02	1.563E-02	2.910E+07	2.482E-02	7.117E-02	1.358E-01	2.070E-01
4510500	RH	.324	.129	.214	.991	2.493E-03	1.289E-03	3.782E-03	3.657E+07	2.495E-01	3.301E-02	1.707E-02	5.008E-02
5112900	SB	.260	.725	.522	.737	1.998E-03	7.240E-03	9.239E-03	1.243E+07	1.037E-02	2.646E-02	9.588E-02	1.223E-01
5213110	TF	.088	.556	.353	.276	6.789E-04	5.556E-03	6.235E-03	8.324E+06	4.799E-02	8.989E-03	7.358E-02	8.256E-02
5313100	I	.688	1.112	.978	1.729	5.294E-03	1.111E-02	1.640E-02	6.375E+07	2.364E+00	7.010E-02	1.471E-01	2.172E-01
5213200	TE	.335	1.194	.778	2.599	2.577E-03	1.153E-02	1.411E-02	9.588E+07	1.437E+00	3.413E-02	1.527E-01	1.868E-01
5313200	I	2.976	9.776	6.818	2.643	2.290E-02	9.767E-02	1.206E-01	9.750E+07	4.281E-02	3.033E-01	1.293E+00	1.597E+00
5213310	TE	.454	1.183	.856	.384	3.497E-03	1.182E-02	1.532E-02	1.415E+07	2.511E-03	4.631E-02	1.565E-01	2.028E-01
5313300	I	3.510	3.881	3.720	3.920	2.701E-02	3.877E-02	6.578E-02	1.446E+08	5.780E-01	3.576E-01	5.134E-01	8.710E-01
5413300	XE	.887	.545	.695	4.058	6.828E-03	5.458E-03	1.229E-02	1.497E+08	3.653E+00	9.042E-02	7.228E-02	1.627E-01
5213400	TE	.176	.717	.433	.547	1.357E-03	7.359E-03	8.715E-03	1.993E+07	2.681E-03	1.796E-02	9.745E-02	1.154E-01
5313400	I	2.953	8.534	6.196	1.991	2.272E-02	8.526E-02	1.080E-01	7.346E+07	1.238E-02	3.009E-01	1.129E+00	1.430E+00

5313500	I	2.431	7.496	5.279	3.114	2.025E-02	7.489E-02	9.513E-02	1.149E+08	1.454E-01	2.681E-01	9.916E-01	1.260E+00
5413500	XE	.436	.443	.470	1.257	4.431E-03	5.426E-03	1.196E-02	4.636E+07	8.170E-07	8.516E-02	7.185E-02	1.570E-01
5513800	CS	1.371	1.949	1.678	.556	1.055E-02	1.947E-02	3.002E-02	1.867E+07	1.926E-03	1.397E-01	2.578E-01	3.975E-01
5613900	BA	3.094	1.139	1.425	1.807	2.381E-02	1.387E-03	2.519E-02	5.927E+07	1.581E-02	3.152E-01	1.837E-02	3.336E-01
5614000	BA	2.042	1.229	1.591	3.427	1.586E-02	1.228E-02	2.814E-02	1.264E+08	7.459E+00	2.101E-01	1.625E-01	3.726E-01
5714000	LA	3.792	12.991	9.288	3.417	2.917E-02	1.298E-01	1.590E-01	1.261E+08	9.745E-01	3.863E-01	1.719E+00	2.105E+00
5714100	LA	5.639	.144	2.515	2.654	4.339E-02	1.438E-03	4.483E-02	9.792E+07	7.282E-02	5.745E-01	1.904E-02	5.936E-01
5814100	CE	.902	.312	.549	2.634	4.939E-03	3.119E-03	1.006E-02	9.718E+07	1.458E+01	9.189E-02	4.130E-02	1.332E-01
5714200	LA	3.265	6.173	5.021	1.604	2.512E-02	6.367E-02	8.879E-02	5.926E+07	1.754E-02	3.327E-01	8.431E-01	1.176E+00
5814300	CE	3.012	1.637	2.736	3.348	2.318E-02	1.636E-02	3.954E-02	1.235E+08	7.834E-01	3.069E-01	2.166E-01	5.235E-01
5914300	PR	2.191	0.000	.953	3.151	1.686E-02	0.	1.696E-02	1.163E+08	7.281E+00	2.232E-01	0.	2.232E-01
5814400	CE	.115	.031	.048	.644	8.857E-04	3.092E-04	1.194E-03	2.385E+07	3.128E+01	1.173E-02	4.081E-03	1.581E-02
5914400	PR	1.753	.033	.741	.647	1.348E-02	3.311E-04	1.382E-02	2.385E+07	1.320E-03	1.786E-01	4.385E-03	1.829E-01
5914500	PR	2.817	.042	1.250	1.843	2.167E-02	4.239E-04	2.210E-02	6.871E+07	7.896E-02	2.870E-01	5.613E-03	2.926E-01
6014700	ND	.669	.253	.434	1.299	5.144E-03	2.526E-03	7.670E-03	4.755E+07	2.410E+00	6.812E-02	3.345E-02	1.016E-01
6114900	PM	.599	.017	.271	.741	4.610E-03	1.742E-04	4.784E-03	2.734E+07	2.790E-01	6.104E-02	2.306E-03	6.334E-02

TABLE B-XI

TMT, UNIT 2, 22-STEP POWER HISTORY, FULL CORE CALC., CINDER-10(LASL) 7/79

32=TIME STEP
 1.80000E+04=TOTAL TIME SINCE LAST TIME AT POWER(S)
 2.93558E+07=TOTAL ELAPSED TIME(S)
 8.26531E+19=FISSIONS/S AT LAST TS AT POWER,(22)
 2.69970E+09=POWER (WATTS) AT LAST TS AT POWER (2.69970E+03 MW)
 6.45228E+02=ACCUMULATED FISSIONS (FISSIONS PER BARN-CM)
 1.39000E+03=TOTAL FP TN SUM PER BARN-CM

1.13087E+20=TOTAL ACTIVITY (DIS/S)
 3.05641E+09=TOTAL CURIES
 7.43671E+00=TOTAL BETA DECAY POWER (MW)
 9.28546E+00=TOTAL GAMMA DECAY POWER (MW)
 1.67222E+01=TOTAL DECAY POWER (MW)
 5.61617E-01=TOTAL BETA MEV/F
 7.01234E-01=TOTAL GAMMA MEV/F
 1.26285E+00=TOTAL DECAY MEV/F

ID	SYM	PERCENT OF ALL FP				MEV/FISS			CURIES	DENSITY	DECAY POWER IN MW		
		BETA	GAMMA	TOTAL	CURIES	BETA	GAMMA	TOTAL			BETA	GAMMA	TOTAL
3609800	KR	.418	2.980	1.841	.691	2.349E-03	2.090E-02	2.325E-02	2.111E+07	1.136E-02	3.110E-02	2.767E-01	3.078E-01
3708800	RR	3.216	1.015	2.335	.772	2.199E-02	7.117E-03	2.911E-02	2.359E+07	1.337E-03	2.912E-01	9.424E-02	3.855E-01
3808900	SR	2.906	0.000	1.292	2.049	1.632E-02	0.	1.632E-02	6.264E+07	1.502E+01	2.161E-01	0.	2.161E-01
3809100	SR	4.365	3.727	4.011	2.747	2.452E-02	2.614E-02	5.065E-02	8.396E+07	1.529E-01	3.246E-01	3.461E-01	6.707E-01
3907100	Y	3.532	.012	1.578	2.393	1.984E-02	8.708E-05	1.993E-02	7.313E+07	1.976E+01	2.627E-01	1.153E-03	2.638E-01
3909110	Y	0.000	1.871	1.039	1.727	0.	1.312E-02	1.312E-02	5.279E+07	8.403E-03	0.	1.737E-01	1.737E-01
3809200	SR	.574	2.923	1.856	1.119	2.944E-03	2.050E-02	2.344E-02	3.420E+07	1.781E-02	3.898E-02	2.714E-01	3.104E-01
3909200	Y	9.944	1.350	5.172	2.788	5.585E-02	9.467E-03	6.532E-02	8.520E+07	5.780E-02	7.395E-01	1.254E-01	8.649E-01
3909300	Y	9.110	.552	4.358	3.157	5.117E-02	3.869E-03	5.503E-02	9.650E+07	1.891E-01	6.775E-01	5.123E-02	7.288E-01
4009500	ZR	.730	3.707	2.379	2.576	4.099E-03	2.594E-02	3.004E-02	7.873E+07	2.378E+01	5.427E-02	3.435E-01	3.978E-01
4109500	NR	.179	2.517	1.477	1.684	1.004E-03	1.765E-02	1.865E-02	5.148E+07	8.334E+00	1.329E-02	2.337E-01	2.470E-01
4009700	ZR	6.011	1.237	3.340	3.499	3.376E-02	8.676E-03	4.243E-02	1.066E+08	3.443E-01	4.470E-01	1.149E-01	5.619E-01
4109700	NR	4.272	4.950	4.649	3.748	2.399E-02	3.471E-02	5.871E-02	1.145E+08	2.700E-02	3.177E-01	4.597E-01	7.774E-01
4109710	NR	0.000	4.362	2.422	3.010	0.	3.059E-02	3.059E-02	9.200E+07	2.652E-04	0.	4.050E-01	4.050E-01
4209900	MD	3.983	1.543	2.628	4.257	2.237E-02	1.082E-02	3.319E-02	1.299E+08	1.648E+00	2.962E-01	1.433E-01	4.395E-01

4309910	TC	0.700	1.067	.570	3.917	0.	7.454E-03	7.454E-03	1.167E+08	1.350E-01	0.	9.871E-02	9.871E-02
4410300	RU	.310	1.802	1.139	1.885	1.741E-03	1.264E-02	1.438E-02	5.760E+07	1.052E+01	2.306E-02	1.673E-01	1.904E-01
4510310	RH	0.000	.144	.091	1.885	0.	1.027E-03	1.027E-03	5.766E+07	1.034E-02	0.	1.360E-02	1.360E-02
4410500	RU	.599	.914	.775	.594	3.365E-03	6.423E-03	9.787E-03	1.821E+07	1.554E-02	4.455E-02	8.505E-02	1.296E-01
4510500	RH	.435	.190	.773	1.171	2.440E-03	1.262E-03	3.703E-03	3.540E+07	2.442E-01	3.231E-02	1.671E-02	4.903E-02
5112900	SR	.220	.637	.453	.252	1.238E-03	4.484E-03	5.722E-03	7.699E+06	6.421E-03	1.639E-02	5.938E-02	7.577E-02
5213110	TE	.113	.739	.441	.254	6.335E-04	5.185E-03	5.819E-03	7.768E+06	4.478E-02	8.389E-03	6.866E-02	7.705E-02
5313100	I	.934	1.977	1.297	2.067	5.246E-03	1.101E-02	1.626E-02	6.318E+07	2.343E+00	6.947E-02	1.458E-01	2.153E-01
5213200	TE	.447	1.601	1.088	3.054	2.510E-03	1.122E-02	1.373E-02	9.335E+07	1.399E+00	3.323E-02	1.486E-01	1.819E-01
5313200	I	4.001	17.645	9.347	3.130	2.247E-02	9.583E-02	1.183E-01	9.566E+07	4.201E-02	2.975E-01	1.269E+00	1.566E+00
5313300	I	4.370	9.074	4.733	4.299	2.454E-02	3.523E-02	5.977E-02	1.314E+08	5.252E-01	3.250E-01	4.665E-01	7.914E-01
5413300	XE	1.215	.778	.972	4.893	6.821E-03	5.452E-03	1.227E-02	1.496E+08	3.649E+00	9.032E-02	7.220E-02	1.625E-01
5313400	I	.560	1.687	1.193	.377	3.143E-03	1.179E-02	1.494E-02	1.016E+07	1.712E-03	4.162E-02	1.562E-01	1.978E-01
5313500	I	2.629	7.797	5.493	2.741	1.476E-02	5.461E-02	6.937E-02	8.378E-02	1.060E-01	1.955E-01	7.231E-01	9.186E-01
5413500	XE	1.406	.950	1.153	1.862	7.896E-03	6.662E-03	1.456E-02	5.692E+07	1.003E-01	1.046E-01	8.821E-02	1.928E-01
5613900	RA	.948	.744	.444	.434	5.324E-03	3.103E-04	5.634E-03	1.325E+07	3.536E-03	7.050E-02	4.108E-03	7.460E-02
5614000	BA	2.806	1.739	2.713	4.109	1.576E-02	1.219E-02	2.795E-02	1.256E+08	7.408E+00	2.086E-01	1.614E-01	3.701E-01
5714000	LA	5.194	19.507	12.597	4.124	2.917E-02	1.298E-01	1.590E-01	1.260E+08	9.745E-01	3.863E-01	1.719E+00	2.105E+00
5714100	LA	4.520	.120	2.077	1.874	2.538E-02	8.414E-04	2.622E-02	5.728E+07	4.260E-02	3.361E-01	1.114E-02	3.473E-01
5814100	CE	1.235	.445	.776	3.179	6.935E-03	3.118E-03	1.005E-02	9.713E+07	1.457E+01	9.183E-02	4.128E-02	1.331E-01
5714200	LA	1.159	2.353	1.822	.503	6.512E-03	1.650E-02	2.301E-02	1.536E+07	4.546E-03	8.623E-02	2.185E-01	3.047E-01
5814300	CE	3.875	2.191	2.940	3.795	2.176E-02	1.536E-02	3.712E-02	1.160E+08	7.356E-01	2.882E-01	2.034E-01	4.916E-01
5914300	PR	3.002	0.000	1.335	3.904	1.686E-02	0.	1.686E-02	1.163E+08	7.282E+00	2.233E-01	0.	2.233E-01
5814400	CE	.158	.044	.035	.780	8.854E-04	3.081E-04	1.194E-03	2.384E+07	3.127E+01	1.172E-02	4.080E-03	1.580E-02
5914400	PR	2.400	.047	1.073	.780	1.348E-02	3.310E-04	1.381E-02	2.384E+07	1.320E-03	1.785E-01	4.383E-03	1.828E-01
5914500	PR	2.726	.043	1.236	1.599	1.531E-02	2.994E-04	1.561E-02	4.853E+07	5.577E-02	2.027E-01	3.964E-03	2.067E-01
6014700	ND	.909	.397	.633	1.543	5.104E-03	2.507E-03	7.610E-03	4.717E+07	2.391E+00	6.758E-02	3.319E-02	1.008E-01
6114900	PM	.797	.024	.359	.849	4.477E-03	1.692E-04	4.646E-03	2.656E+07	2.710E-01	5.928E-02	2.240E-03	6.152E-02

TABLE B-XII

TMT, UNIT 2, 22-STEP POWER HISTORY, FULL CORE CALC., CINDER-101(LASL) 7/79

33=TIME STEP
 3.60000E+04=TOTAL TIME SINCE LAST TIME AT POWER(S)
 2.93738E+07=TOTAL ELAPSED TIME(S)
 8.26531E+19=FISSIONS/S AT LAST TS AT POWER (22)
 2.69970E+09=POWER (WATTS) AT LAST TS AT POWER (2.69970E+03 MW)
 6.95228E+02=ACCUMULATED FISSIONS (FISSIONS PER BARN-CM)
 1.39000E+03=TOTAL FP IN SUM PER BARN-CM

9.59714E+19=TOTAL ACTIVITY (DIS/S)
 2.59382E+09=TOTAL CURIES
 5.59288E+00=TOTAL BETA DECAY POWER (MW)
 7.40486E+00=TOTAL GAMMA DECAY POWER (MW)
 1.29977E+01=TOTAL DECAY POWER (MW)
 4.22372E-01=TOTAL BETA MEV/F
 5.59211E-01=TOTAL GAMMA MEV/F
 9.81583E-01=TOTAL DECAY MEV/F

ID	SYM	PERCENT OF ALL FP				MEV/FISS			DECAY POWER IN MW				
		BETA	GAMMA	TOTAL	CURIES	BETA	GAMMA	TOTAL	CURIES	DENSITY	BETA	GAMMA	TOTAL
3608800	KR	.161	1.084	.697	.736	6.812E-04	6.061E-03	6.742E-03	6.121E+06	3.294E-03	9.020E-03	8.026E-02	8.928E-02
3708800	RA	1.510	.369	.850	.264	6.379E-03	2.064E-03	8.443E-03	6.842E+06	3.879E-04	8.447E-02	2.733E-02	1.118E-01
3808900	SR	3.853	0.000	1.658	2.498	1.627E-02	0.	1.627E-02	6.247E+07	1.498E+01	2.155E-01	0.	2.155E-01

3809100	SR	4.027	3.243	3.540	2.246	1.701E-02	1.813E-02	3.514E-02	5.825E+07	1.061E-01	2.252E-01	2.401E-01	4.693E-01
3909100	Y	4.697	.016	2.030	2.819	1.984E-02	8.708E-05	1.993E-02	7.313E+07	1.976E+01	2.627E-01	1.153E-03	2.638E-01
3909110	Y	0.000	1.431	.929	1.415	0.	9.119E-03	9.119E-03	3.670E+07	5.841E-03	0.	1.208E-01	1.208E-01
3809200	SR	.194	1.020	.445	.367	8.194E-04	5.705E-03	6.525E-03	9.519E+06	4.957E-03	1.085E-02	7.555E-02	8.640E-02
3909200	Y	6.642	.850	3.343	1.650	2.806E-02	4.756E-03	3.281E-02	4.280E+07	2.904E-02	3.715E-01	6.298E-02	4.345E-01
3909300	Y	8.624	.493	3.922	2.442	3.643E-02	2.755E-03	3.918E-02	6.870E+07	1.347E-01	4.823E-01	3.647E-02	5.188E-01
4009500	ZR	.968	4.629	3.054	3.029	4.090E-03	2.589E-02	2.998E-02	7.856E+07	2.373E+01	5.415E-02	3.428E-01	3.969E-01
4109500	NR	.238	3.163	1.925	1.999	1.006E-03	1.769E-02	1.869E-02	5.160E+07	8.352E+00	1.332E-02	2.342E-01	2.476E-01
4004700	ZR	6.502	1.262	3.517	3.345	2.746E-02	7.059E-03	3.452E-02	8.676E+07	2.801E-01	3.637E-01	9.347E-02	4.571E-01
4104700	NR	4.644	5.075	4.889	3.610	1.961E-02	2.838E-02	4.799E-02	9.363E+07	2.207E-02	2.597E-01	3.758E-01	6.355E-01
4109710	NR	0.000	4.450	2.535	2.886	0.	2.489E-02	2.489E-02	7.485E+07	2.158E-04	0.	3.295E-01	3.295E-01
4209900	MD	5.026	1.836	3.228	4.752	2.123E-02	1.027E-02	3.149E-02	1.232E+08	1.564E+00	2.811E-01	1.359E-01	4.170E-01
4309910	TC	0.000	1.294	.737	4.367	0.	7.238E-03	7.238E-03	1.133E+08	1.310E-01	0.	9.584E-02	9.584E-02
4410300	RU	.411	2.251	1.459	2.213	1.735E-03	1.259E-02	1.432E-02	5.739E+07	1.048E+01	2.297E-02	1.667E-01	1.897E-01
4510310	RH	0.000	.183	.124	2.215	0.	1.023E-03	1.023E-03	5.745E+07	1.030E-02	0.	1.355E-02	1.355E-02
4410500	RU	.365	.526	.457	.322	1.542E-03	2.943E-03	4.484E-03	8.345E+06	7.120E-03	2.041E-02	3.896E-02	5.938E-02
4510500	RH	.543	.212	.354	1.296	2.292E-03	1.186E-03	3.478E-03	3.363E+07	2.294E-01	3.035E-02	1.570E-02	4.606E-02
5213110	TE	.134	.825	.528	.267	5.644E-04	4.619E-03	5.184E-03	6.920E+06	3.990E-02	7.473E-03	6.117E-02	6.864E-02
5313100	I	1.223	1.938	1.630	2.397	5.164E-03	1.084E-02	1.600E-02	6.218E+07	2.306E+00	6.838E-02	1.435E-01	2.119E-01
5213200	TE	.568	1.920	1.338	3.443	2.400E-03	1.074E-02	1.314E-02	8.930E+07	1.338E+00	3.179E-02	1.422E-01	1.740E-01
5313200	I	5.109	18.458	11.575	3.542	2.158E-02	9.204E-02	1.136E-01	9.188E+07	4.034E-02	2.858E-01	1.219E+00	1.504E+00
5313300	I	4.921	5.336	5.157	4.291	2.078E-02	2.984E-02	5.062E-02	1.113E+08	4.449E-01	2.752E-01	3.951E-01	6.703E-01
5413300	XE	1.607	.970	1.244	5.739	6.789E-03	5.427E-03	1.222E-02	1.488E+08	3.632E+00	8.989E-02	7.186E-02	1.617E-01
5313500	I	2.065	5.769	4.175	1.908	8.722E-03	3.226E-02	4.098E-02	4.950E+07	6.264E-02	1.155E-01	4.272E-01	5.427E-01
5413500	XE	1.947	1.240	1.544	2.285	8.222E-03	6.936E-03	1.516E-02	5.927E+07	1.044E-01	1.089E-01	9.185E-02	2.007E-01
5614000	BA	3.689	2.156	2.815	4.787	1.558E-02	1.206E-02	2.763E-02	1.242E+08	7.325E+00	2.063E-01	1.596E-01	3.659E-01
5714000	LA	6.902	23.190	16.191	4.856	2.915E-02	1.297E-01	1.588E-01	1.260E+08	9.737E-01	3.860E-01	1.717E+00	2.103E+00
5714100	LA	2.454	.051	1.091	.902	1.037E-02	3.436E-04	1.071E-02	2.339E+07	1.740E-02	1.373E-01	4.550E-03	1.418E-01
5814100	CE	1.637	.556	1.021	3.734	6.916E-03	3.109E-03	1.002E-02	9.687E+07	1.453E+01	9.158E-02	4.117E-02	1.327E-01
5814300	CE	4.639	2.473	3.425	4.026	1.959E-02	1.383E-02	3.342E-02	1.044E+08	6.622E-01	2.594E-01	1.831E-01	4.426E-01
5914300	PR	3.990	0.000	1.717	4.480	1.685E-02	0.	1.685E-02	1.162E+08	7.278E+00	2.231E-01	0.	2.231E-01
5814400	CF	.210	.055	.122	.919	8.850E-04	3.080E-04	1.193E-03	2.383E+07	3.126E+01	1.172E-02	4.078E-03	1.580E-02
5914400	PR	3.189	.059	1.426	.919	1.347E-02	3.308E-04	1.380E-02	2.383E+07	1.319E-03	1.784E-01	4.380E-03	1.828E-01
5914500	PR	2.030	.030	.821	1.049	8.575E-03	1.677E-04	8.743E-03	2.718E+07	3.124E-02	1.135E-01	2.220E-03	1.158E-01
6014700	ND	1.193	.442	.745	1.795	5.037E-03	2.474E-03	7.511E-03	4.656E+07	2.360E+00	6.670E-02	3.276E-02	9.946E-02
6114900	PM	.997	.028	.445	.953	4.210E-03	1.591E-04	4.369E-03	2.497E+07	2.548E-01	5.575E-02	2.107E-03	5.786E-02

TABLE B-XIII

TMT, UNIT 2, 22-STEP POWER HISTORY, FULL CORE CALC., CINDER-10(LASL) 7/79

34=TIME STEP

7.20000E+04=TOTAL TIME SINCE LAST TIME AT POWER(S)
 2.94098E+07=TOTAL FLAPSED TIME(S)
 8.26531E+19=FISSIONS/S AT LAST TS AT POWER, (22)
 2.69970E+09=POWER (WATTS) AT LAST TS AT POWER (2.69970E+03 MW)
 6.95228E+02=ACCUMULATED FISSIONS (FISSIONS PER BARN-CM)
 1.39000E+03=TOTAL FP IN SIM PER BARN-CM

7.90343E+19=TOTAL ACTIVITY (DYS/S)
 2.13606E+09=TOTAL CURTES
 4.05154E+00=TOTAL BETA DEFCAY POWER (MW)
 5.96590E+00=TOTAL GAMMA DEFCAY POWER (MW)
 1.00174E+01=TOTAL DECAY POWER (MW)
 3.05970E-01=TOTAL BETA MFV/F
 4.50542E-01=TOTAL GAMMA MFV/F
 7.56512E-01=TOTAL DECAY MFV/F

ID ZZAAAS	SYM	PERCENT OF ALL FP			MEV/FISS			DECAY POWER IN MW					
		BETA	GAMMA	TOTAL	BETA	GAMMA	TOTAL	BETA	GAMMA	TOTAL			
3808900	SR	5.289	0.007	2.139	2.929	1.618E-02	0.	1.619E-02	6.212E+07	1.490E+01	2.143E-01	0.	2.143E-01
3809100	SR	2.676	1.927	2.236	1.313	8.187E-03	8.728E-03	1.692E-02	2.804E+07	5.108E-02	1.084E-01	1.156E-01	2.240E-01
3909100	Y	6.471	.019	2.429	3.417	1.980E-02	8.691E-05	1.989E-02	7.298E+07	1.973E+01	2.622E-01	1.151E-03	2.633E-01
3909110	Y	0.300	.974	.490	.827	0.	4.390E-03	4.390E-03	1.766E+07	2.812E-03	0.	5.813E-02	5.813E-02
3909200	Y	1.711	.197	.829	.374	5.234E-03	8.873E-04	6.122E-03	7.986E+06	5.417E-03	6.931E-02	1.175E-02	8.106E-02
3909300	Y	6.034	.310	2.425	1.630	1.846E-02	1.396E-03	1.986E-02	3.482E+07	6.825E-02	2.445E-01	1.849E-02	2.630E-01
4009500	ZR	1.331	5.720	3.944	3.642	4.072E-03	2.577E-02	2.984E-02	7.821E+07	2.363E+01	5.392E-02	3.413E-01	3.952E-01
4109500	NB	.330	3.943	2.482	2.426	1.010E-03	1.776E-02	1.877E-02	5.182E+07	8.388E+00	1.338E-02	2.352E-01	2.486E-01
4009700	ZR	5.941	1.937	3.021	2.649	1.818E-02	4.673E-03	2.285E-02	5.743E+07	1.854E-01	2.407E-01	6.187E-02	3.026E-01
4109700	NB	4.245	4.171	4.271	2.993	1.299E-02	1.879E-02	3.178E-02	6.200E+07	1.462E-02	1.720E-01	2.488E-01	4.208E-01
4109710	NR	0.000	3.656	2.178	2.120	0.	1.647E-02	1.647E-02	4.955E+07	1.428E-04	0.	2.181E-01	2.181E-01
4209900	MD	6.246	2.051	3.748	5.195	1.911E-02	9.242E-03	2.835E-02	1.110E+08	1.408E+00	2.531E-01	1.224E-01	3.754E-01
4309910	TC	0.000	1.478	.490	4.877	0.	6.657E-03	6.657E-03	1.042E+08	1.205E-01	0.	8.815E-02	8.815E-02
4410300	RU	.563	2.774	1.490	2.647	1.722E-03	1.250E-02	1.422E-02	5.697E+07	1.041E+01	2.281E-02	1.655E-01	1.883E-01
4510310	RH	0.000	.225	.134	2.670	0.	1.016E-03	1.016E-03	5.703E+07	1.023E-02	0.	1.345E-02	1.345E-02
4510500	RH	.632	.222	.388	1.329	1.935E-03	1.001E-03	2.936E-03	2.839E+07	1.937E-01	2.562E-02	1.325E-02	3.888E-02
4510600	RH	.611	.057	.291	.135	1.869E-03	2.578E-04	2.127E-03	2.888E+06	4.609E-06	2.475E-02	3.414E-03	2.816E-02
5213110	TE	.144	.814	.844	.257	4.480E-04	3.666E-03	4.114E-03	5.493E+06	3.167E-02	5.932E-03	4.855E-02	5.448E-02
5313100	I	1.634	2.329	2.044	2.819	5.000E-03	1.049E-02	1.549E-02	6.021E+07	2.233E+00	6.620E-02	1.389E-01	2.051E-01
5213200	TE	.718	2.190	1.599	3.825	2.196E-03	9.824E-03	1.202E-02	8.170E+07	1.225E+00	2.908E-02	1.301E-01	1.592E-01
5313200	I	6.461	19.713	13.757	3.940	1.977E-02	8.431E-02	1.041E-01	8.416E+07	3.696E-02	2.618E-01	1.116E+00	1.378E+00
5313300	I	4.868	4.746	4.725	3.734	1.489E-02	2.138E-02	3.628E-02	7.976E+07	3.188E-01	1.972E-01	2.831E-01	4.804E-01
5413300	XE	2.178	1.182	1.885	6.840	6.664E-03	3.327E-03	1.199E-02	1.461E+08	3.565E+00	8.824E-02	7.054E-02	1.588E-01
5313500	I	.995	2.422	1.831	.829	3.044E-03	1.126E-02	1.430E-02	1.728E+07	2.186E-02	4.031E-02	1.491E-01	1.894E-01
5413500	XE	1.955	1.120	1.457	2.018	5.980E-03	5.045E-03	1.103E-02	4.311E+07	7.596E-02	7.919E-02	6.680E-02	1.460E-01
5614000	BA	4.978	2.614	3.971	5.684	1.523E-02	1.179E-02	2.702E-02	1.214E+08	7.162E+00	2.017E-01	1.561E-01	3.578E-01
5714000	LA	9.489	28.667	20.911	5.873	2.903E-02	1.292E-01	1.582E-01	1.254E+08	9.698E-01	3.844E-01	1.710E+00	2.095E+00
5714100	LA	.965	.013	.236	.193	1.729E-03	5.731E-05	1.785E-03	3.902E+06	2.902E-03	2.289E-02	7.588E-04	2.365E-02
5814100	CE	2.243	.685	1.315	4.499	6.862E-03	3.085E-03	9.946E-03	9.611E+07	1.442E+01	9.086E-02	4.085E-02	1.317E-01
5814300	CE	5.190	2.489	3.591	3.943	1.588E-02	1.121E-02	2.709E-02	8.464E+07	5.368E-01	2.103E-01	1.484E-01	3.587E-01
5914300	PR	5.485	0.000	2.219	5.419	1.678E-02	0.	1.678E-02	1.157E+08	7.249E+00	2.222E-01	0.	2.222E-01
5814400	CE	.289	.068	.158	1.114	8.841E-04	3.077E-04	1.192E-03	2.381E+07	3.122E+01	1.171E-02	4.074E-03	1.578E-02
5914400	PR	4.398	.073	1.823	1.114	1.346E-02	3.305E-04	1.379E-02	2.381E+07	1.318E-03	1.782E-01	4.376E-03	1.826E-01
5914500	PR	.879	.012	.353	.309	2.691E-03	5.262E-05	2.743E-03	8.529E+06	9.802E-03	3.563E-02	6.967E-04	3.632E-02
6014700	ND	1.604	.435	.967	2.123	4.906E-03	2.410E-03	7.316E-03	4.535E+07	2.299E+00	6.497E-02	3.191E-02	9.688E-02
6114900	PM	1.208	.031	.507	1.027	3.697E-03	1.397E-04	3.837E-03	2.193E+07	2.238E-01	4.896E-02	1.850E-03	5.081E-02

TABLE B-XIV

TMT, UNIT 2, 22-STEP POWER HISTORY, FULL CORE CALC., CINDER-10(LASL) 7/79

35=TIME STEP
1.80000E+05=TOTAL TIME SINCE LAST TIME AT POWER(S)
2.95178E+07=TOTAL ELAPSED TIME(S)
8.26531E+19=FISSIONS/CM AT LAST TS AT POWER, (22)
2.69970E+09=POWER (WATTS) AT LAST TS AT POWER (2.69970E+03 MW)
6.95228E+02=ACCUMULATED FISSIONS (FISSIONS PER BARN-CM)
1.39000E+03=TOTAL FP IN SYM PER BARN-CM

3.90702E+19=TOTAL ACTIVITY (DIS/S)
 1.59649E+04=TOTAL CURIES
 2.72759E+00=TOTAL BETA DECAY POWER (MW)
 4.43434E+00=TOTAL GAMMA DECAY POWER (MW)
 7.16193E+00=TOTAL DECAY POWER (MW)
 2.05986E-01=TOTAL BETA MEV/F
 3.34879E-01=TOTAL GAMMA MEV/F
 3.40866E-01=TOTAL DECAY MEV/F

ID ZZAAAS	SYM	-----PERCENT OF ALL FP-----			-----MEV/FISS-----			---DECAY POWER IN MW---					
		BETA	GAMMA	TOTAL	CURIES	BETA	GAMMA	TOTAL	CURIES	DENSITY	BETA	GAMMA	TOTAL
3808900	SR	7.727	0.000	2.943	3.427	1.592E-02	0.	1.592E-02	6.109E+07	1.465E+01	2.108E-01	0.	2.108E-01
3909100	Y	9.494	.026	3.632	4.515	1.956E-02	8.584E-05	1.964E-02	7.209E+07	1.948E+01	2.590E-01	1.137E-03	2.601E-01
3909300	Y	1.167	.054	.474	.744	2.404E-03	1.818E-04	2.586E-03	4.533E+06	8.886E-03	3.183E-02	2.407E-03	3.424E-02
4004500	ZR	1.951	7.595	3.445	4.435	4.018E-03	2.543E-02	2.945E-02	7.719E+07	2.332E+01	5.321E-02	3.368E-01	3.900E-01
4109500	NB	.496	5.369	3.513	3.785	1.023E-03	1.798E-02	1.900E-02	5.245E+07	8.490E+00	1.354E-02	2.381E-01	2.516E-01
4009700	ZP	2.560	.405	1.225	1.043	5.273E-03	1.355E-03	6.628E-03	1.666E+07	5.377E-02	6.982E-02	1.794E-02	8.776E-02
4109700	NB	1.829	1.427	1.704	1.126	3.767E-03	5.450E-03	9.217E-03	1.798E+07	4.239E-03	4.988E-02	7.217E-02	1.220E-01
4109710	NR	0.000	1.427	.993	.900	0.	4.778E-03	4.778E-03	1.437E+07	4.142E-05	0.	6.327E-02	6.327E-02
4209900	MO	6.771	2.014	3.826	5.072	1.395E-02	6.745E-03	2.069E-02	8.098E+07	1.027E+00	1.847E-01	8.932E-02	2.740E-01
4304910	TC	0.000	1.467	.978	4.814	0.	4.911E-03	4.911E-03	7.686E+07	8.892E-02	0.	6.503E-02	6.503E-02
4410300	RU	.818	3.651	2.572	3.491	1.685E-03	1.223E-02	1.391E-02	5.574E+07	1.018E+01	2.231E-02	1.619E-01	1.842E-01
4510310	RH	0.000	.297	.144	3.495	0.	9.936E-04	9.936E-04	5.580E+07	1.001E-02	0.	1.316E-02	1.316E-02
4510500	RH	.527	.168	.375	.998	1.087E-03	5.620E-04	1.649E-03	1.594E+07	1.087E-01	1.439E-02	7.442E-03	2.183E-02
4510600	RH	.905	.077	.372	.180	1.864E-03	2.572E-04	2.122E-03	2.881E+06	4.598E-06	2.469E-02	3.406E-03	2.809E-02
5213110	TE	.109	.547	.390	.172	2.240E-04	1.833E-03	2.057E-03	2.746E+06	1.583E-02	2.966E-03	2.427E-02	2.724E-02
5313100	I	2.196	2.834	2.521	3.411	4.522E-03	9.491E-03	1.401E-02	5.446E+07	2.020E+00	5.989E-02	1.257E-01	1.856E-01
5213200	TE	.817	2.247	1.732	3.920	1.682E-03	7.525E-03	9.207E-03	6.258E+07	9.381E-01	2.228E-02	9.964E-01	1.219E-01
5313200	I	7.351	19.285	14.740	4.034	1.514E-02	6.458E-02	7.973E-02	6.447E+07	2.831E-02	2.005E-01	8.552E-01	1.056E+00
5313300	I	2.661	2.357	2.454	1.834	5.481E-03	7.868E-03	1.335E-02	2.935E+07	1.173E-01	7.258E-02	1.042E-01	1.768E-01
5413300	XE	2.424	1.438	2.004	8.273	6.023E-03	4.815E-03	1.084E-02	1.321E+08	3.222E+00	7.976E-02	6.376E-02	1.435E-01
5614000	BA	6.710	3.289	4.668	7.106	1.423E-02	1.101E-02	2.525E-02	1.135E+08	6.692E+00	1.885E-01	1.458E-01	3.343E-01
5714000	LA	13.714	37.526	28.457	7.645	2.825E-02	1.257E-01	1.539E-01	1.221E+08	9.436E-01	3.741E-01	1.664E+00	2.038E+00
5814100	CE	3.244	.897	1.791	5.863	6.683E-03	3.004E-03	9.687E-03	9.360E+07	1.404E+01	8.849E-02	3.978E-02	1.283E-01
5814300	CE	4.106	1.782	2.657	2.823	8.457E-03	5.969E-03	1.443E-02	4.507E+07	2.858E-01	1.120E-01	7.904E-02	1.910E-01
5914300	PR	7.917	0.000	3.015	7.044	1.631E-02	0.	1.631E-02	1.125E+08	7.043E+00	2.159E-01	0.	2.159E-01
5814400	CE	.428	.092	.220	1.447	8.814E-04	3.067E-04	1.189E-03	2.373E+07	3.113E+01	1.167E-02	4.061E-03	1.573E-02
5914400	PR	6.513	.098	2.541	1.447	1.342E-02	3.295E-04	1.375E-02	2.373E+07	1.314E-03	1.777E-01	4.363E-03	1.820E-01
6014700	ND	2.201	.665	1.250	2.625	4.534E-03	2.227E-03	6.761E-03	4.191E+07	2.124E+00	6.004E-02	2.949E-02	8.953E-02
6114900	PH	1.213	.028	.480	.929	2.499E-03	9.444E-05	2.594E-03	1.483E+07	1.513E-01	3.309E-02	1.251E-03	3.435E-02

TABLE B-XV

TMT, UNIT 2, 22-STEP POWER HISTORY, FULL CORE CALC., CINDER-10(LASL) 7/79

36=TIME STEP
 3.60000E+05=TOTAL TIME SINCE LAST TIME AT POWER(S)
 2.96978E+07=TOTAL ELAPSED TIME(S)
 8.26531E+19=FISSIONS/S AT LAST TS AT POWER, (22)
 2.69970E+09=POWER (WATTS) AT LAST TS AT POWER (2.69970E+03 MW)
 6.95228E+02=ACCUMULATED FISSIONS (FISSIONS PER BARN-CM)
 1.39000E+03=TOTAL FP TN SUM PER BARN-CM

4.66281E+19=TOTAL ACTIVITY (DTS/S)
 1.26022E+09=TOTAL CURIES
 2.11693E+00=TOTAL BETA DECAY POWER (MW)
 3.49121E+00=TOTAL GAMMA DECAY POWER (MW)
 5.40815E+00=TOTAL DECAY POWER (MW)
 1.59870E-01=TOTAL BETA MEV/F
 2.63655E-01=TOTAL GAMMA MEV/F
 4.23525E-01=TOTAL DECAY MEV/F

ID ZZAAAS	SYM	-----PERCENT OF ALL FP-----				-----MEV/FISS-----			---DECAY POWER IN MW---				
		BETA	GAMMA	TOTAL	CURIES	BETA	GAMMA	TOTAL	CURIES	DENSITY	BETA	GAMMA	TOTAL
3808900	SR	9.683	0.000	7.655	4.715	1.548E-02	0.	1.548E-02	5.942E+07	1.425E+01	2.050E-01	0.	2.050E-01
3909100	Y	11.938	.072	4.526	5.583	1.909E-02	8.378E-05	1.917E-02	7.036E+07	1.901E+01	2.527E-01	1.109E-03	2.538E-01
4009500	ZR	2.459	9.434	6.972	5.991	3.931E-03	2.488E-02	2.881E-02	7.550E+07	2.281E+01	5.205E-02	3.294E-01	3.815E-01
4109500	NR	.651	6.945	4.549	4.238	1.041E-03	1.831E-02	1.935E-02	5.341E+07	8.646E+00	1.379E-02	2.425E-01	2.562E-01
4209900	MD	5.161	1.513	2.870	3.802	8.251E-03	3.990E-03	1.224E-02	4.791E+07	6.078E-01	1.093E-01	5.284E-02	1.621E-01
4309910	TC	0.000	1.103	.696	3.610	0.	2.907E-03	2.907E-03	4.549E+07	5.263E-02	0.	3.849E-02	3.849E-02
4410300	RU	1.016	4.472	3.147	4.265	1.625E-03	1.179E-02	1.341E-02	5.375E+07	9.816E+00	2.151E-02	1.561E-01	1.776E-01
4510310	RH	0.000	.363	.226	4.269	0.	9.580E-04	9.580E-04	5.380E+07	9.649E-03	0.	1.269E-02	1.269E-02
4510600	RH	1.162	.077	.479	.278	1.857E-03	2.562E-04	2.113E-03	2.870E+06	4.580E-06	2.459E-02	3.393E-03	2.798E-02
5313100	I	2.378	7.025	7.781	3.632	3.801E-03	7.976E-03	1.178E-02	4.577E+07	1.697E+00	5.031E-02	1.056E-01	1.560E-01
5213200	TE	.475	1.830	1.374	3.185	1.079E-03	4.825E-03	5.904E-03	4.013E+07	6.015E-01	1.429E-02	6.390E-02	7.818E-02
5313200	I	6.074	15.708	12.071	3.281	9.710E-03	4.141E-02	5.112E-02	4.134E+07	1.815E-02	1.286E-01	5.484E-01	6.770E-01
5313300	I	.648	.944	.594	.440	1.036E-03	1.487E-03	2.522E-03	5.546E+06	2.217E-02	1.371E-02	1.969E-02	3.340E-02
5413300	XE	2.981	1.445	2.025	8.293	4.766E-03	3.810E-03	8.576E-03	1.045E+08	2.550E+00	6.311E-02	5.045E-02	1.136E-01
5614000	BA	7.953	3.732	5.325	8.041	1.271E-02	9.838E-03	2.255E-02	1.013E+08	5.978E+00	1.684E-01	1.303E-01	2.986E-01
5714000	LA	16.363	44.132	33.854	8.969	2.616E-02	1.164E-01	1.425E-01	1.130E+08	8.738E-01	3.464E-01	1.541E+00	1.887E+00
5814100	CE	3.999	1.090	2.198	7.105	6.392E-03	2.874E-03	9.266E-03	8.953E+07	1.343E+01	8.465E-02	3.805E-02	1.227E-01
5814300	CE	1.851	.792	1.192	1.251	2.959E-03	2.088E-03	5.047E-03	1.577E+07	1.000E-01	3.918E-02	2.765E-02	6.683E-02
5914300	PR	9.424	0.000	3.557	8.245	1.507E-02	0.	1.507E-02	1.039E+08	6.508E+00	1.995E-01	0.	1.995E-01
5814400	CE	.549	.116	.279	1.874	8.769E-04	3.052E-04	1.192E-03	2.361E+07	3.097E+01	1.161E-02	4.041E-03	1.565E-02
5914400	PR	8.349	.174	3.229	1.874	1.335E-02	3.278E-04	1.368E-02	2.361E+07	1.307E-03	1.769E-01	4.341E-03	1.811E-01
6014700	ND	2.487	.741	1.400	2.916	3.976E-03	1.953E-03	5.929E-03	3.675E+07	1.863E+00	5.265E-02	2.586E-02	7.851E-02
6114900	PM	.814	.019	.319	.613	1.301E-03	4.917E-05	1.350E-03	7.719E+06	7.877E-02	1.723E-02	6.911E-04	1.788E-02

TABLE B-XVI

TMI, UNIT 2, 22-STEP POWER HISTORY, FULL CORE CALC., CINDER-10(LASL) 7/79

37=TIME STEP

7.20000E+05=TOTAL TIME SINCE LAST TIME AT POWER(S)
 3.00578E+07=TOTAL ELAPSED TIME(S)
 8.26531E+19=FISSIONS/S AT LAST TS AT POWER (22)
 2.69970E+09=POWER (WATTS) AT LAST TS AT POWER (2.69970E+03 MW)
 6.95228E+02=ACCUMULATED FISSIONS (FISSIONS PER BARN-CM)
 1.39000E+03=TOTAL FP IN SIM PER BARN-CM

3.54130E+19=TOTAL ACTIVITY (DTS/S)
 9.57109E+08=TOTAL CURIES
 1.64313E+00=TOTAL BETA DECAY POWER (MW)
 2.59033E+00=TOTAL GAMMA DECAY POWER (MW)
 4.23346E+00=TOTAL DECAY POWER (MW)

1.24088E-01=TOTAL BETA MFV/F
 1.95620E-01=TOTAL GAMMA MFV/F
 3.19709E-01=TOTAL DECAY MFV/F

ID ZZAAAS	SYM	-----PERCENT OF		ALL FP-----		-----MEV/FISS-----			CURIES	DENSITY	---DECAY POWER IN MW---		
		BETA	GAMMA	TOTAL	CURIES	BETA	GAMMA	TOTAL			BETA	GAMMA	TOTAL
3808900	SR	11.902	0.000	4.591	5.873	1.464E-02	0.	1.464E-02	5.621E+07	1.348E+01	1.939E-01	0.	1.939E-01
3909100	Y	14.641	.041	5.709	6.997	1.817E-02	7.975E-05	1.825E-02	6.697E+07	1.810E+01	2.406E-01	1.056E-03	2.416E-01
4009500	ZR	3.031	17.170	8.623	7.948	3.761E-03	2.381E-02	2.757E-02	7.225E+07	2.183E+01	4.980E-02	3.152E-01	3.650E-01
4109500	NB	.865	9.649	6.236	5.749	1.073E-03	1.886E-02	1.994E-02	5.502E+07	8.907E+00	1.421E-02	2.498E-01	2.640E-01
4209900	MO	2.327	.714	1.340	1.757	2.888E-03	1.396E-03	4.284E-03	1.677E+07	2.127E-01	3.824E-02	1.849E-02	5.673E-02
4309910	TC	0.000	.527	.319	1.663	0.	1.017E-03	1.017E-03	1.592E+07	1.842E-02	0.	1.347E-02	1.347E-02
4410300	RU	1.217	5.609	3.971	5.770	1.510E-03	1.096E-02	1.247E-02	4.997E+07	9.125E+00	2.000E-02	1.451E-01	1.651E-01
4510310	RH	0.000	.455	.279	5.776	0.	8.906E-04	8.906E-04	5.001E+07	8.970E-03	0.	1.179E-02	1.179E-02
4510600	RH	1.485	.130	.656	.797	1.843E-03	2.542E-04	2.097E-03	2.847E+06	4.545E-06	2.440E-02	3.366E-03	2.777E-02
5313100	I	2.145	7.855	2.590	3.349	2.662E-03	5.586E-03	8.248E-03	3.206E+07	1.189E+00	3.525E-02	7.397E-02	1.092E-01
5213200	TE	.357	1.014	.799	1.724	4.436E-04	1.984E-03	2.428E-03	1.650E+07	2.474E-01	5.874E-03	2.627E-02	3.215E-02
5313200	I	3.218	8.705	6.576	1.775	3.993E-03	1.703E-02	2.107E-02	1.700E+07	7.465E-03	5.287E-02	2.255E-01	2.784E-01
5413300	XE	2.267	1.150	1.593	6.445	2.813E-03	2.249E-03	5.067E-03	6.168E+07	1.505E+00	3.725E-02	2.978E-02	6.703E-02
5614000	BA	8.175	4.073	5.679	8.448	1.014E-02	7.850E-03	1.799E-02	8.086E+07	4.770E+00	1.343E-01	1.039E-01	2.383E-01
5714000	LA	17.236	49.639	36.450	9.655	2.139E-02	9.515E-02	1.165E-01	9.241E+07	7.144E-01	2.832E-01	1.260E+00	1.543E+00
5814100	CE	4.714	1.344	2.652	8.560	5.849E-03	2.630E-03	8.479E-03	8.193E+07	1.229E+01	7.745E-02	3.482E-02	1.123E-01
5914300	PR	9.958	0.000	3.855	8.904	1.236E-02	0.	1.235E-02	8.522E+07	5.337E+00	1.636E-01	0.	1.636E-01
5814400	CE	.700	.154	.346	2.447	8.680E-04	3.021E-04	1.170E-03	2.337E+07	3.066E+01	1.149E-02	4.000E-03	1.549E-02
5914400	PR	10.648	.166	4.234	2.442	1.321E-02	3.245E-04	1.394E-02	2.337E+07	1.294E-03	1.750E-01	4.297E-03	1.793E-01
6014700	ND	2.464	.768	1.426	2.952	3.057E-03	1.502E-03	4.559E-03	2.826E+07	1.432E+00	4.048E-02	1.988E-02	6.037E-02

TABLE B-XVII

TMT, UNIT 2, 22-STEP POWER HISTORY, FULL CORE CALC., CINDER-10(LASL) 7/79

38=TIME STEP

1.80000E+06=TOTAL TIME SINCE LAST TIME AT POWER(S)
 3.11378E+07=TOTAL ELAPSED TIME(S)
 8.26531E+19=FISSIONS/S AT LAST TS AT POWER.(22)
 2.69970E+09=POWER (WATTS) AT LAST TS AT POWER (2.69970E+03 MW)
 6.95228E+02=ACCUMULATED FISSIONS (FISSIONS PER BARN-CM)
 1.39000E+03=TOTAL FP IN SIM PER BARN-CM

2.24734E+19=TOTAL ACTIVITY (DTS/S)
 6.07389E+08=TOTAL CURIES
 1.07388E+00=TOTAL BETA DECAY POWER (MW)
 1.48182E+00=TOTAL GAMMA DECAY POWER (MW)
 2.55570E+00=TOTAL DECAY POWER (MW)
 8.10989E-02=TOTAL BETA MFV/F
 1.11906E-01=TOTAL GAMMA MFV/F
 1.93005E-01=TOTAL DECAY MFV/F

ID ZZAAAS	SYM	PERCENT OF ALL FP				MEV/FISS			CURIES	DENSITY	---DECAY POWER IN MW---		
		BETA	GAMMA	TOTAL	CURIES	BETA	GAMMA	TOTAL			BETA	GAMMA	TOTAL
3808900	SR	15.286	0.000	6.429	7.834	1.240E-02	0.	1.240E-02	4.758E+07	1.141E+01	1.642E-01	0.	1.642E-01
3909100	Y	19.324	.061	8.155	9.511	1.567E-02	6.879E-05	1.574E-02	5.777E+07	1.561E+01	2.075E-01	9.109E-04	2.084E-01
4009500	ZR	4.063	19.639	17.514	10.471	3.295E-03	2.086E-02	2.415E-02	6.330E+07	1.912E+01	4.363E-02	2.762E-01	3.198E-01
4109500	NB	1.389	17.696	10.843	9.579	1.126E-03	1.980E-02	2.093E-02	5.776E+07	9.350E+00	1.491E-02	2.622E-01	2.771E-01
4410300	RU	1.496	7.849	5.172	6.610	1.214E-03	8.806E-03	1.002E-02	4.015E+07	7.332E+00	1.607E-02	1.166E-01	1.327E-01
4510310	RH	0.000	.639	.371	6.616	0.	7.156E-04	7.156E-04	4.019E+07	7.208E-03	0.	9.476E-03	9.476E-03
4510600	RH	2.219	.222	1.041	.459	1.800E-03	2.483E-04	2.048E-03	2.781E+06	4.439E-06	2.383E-02	3.288E-03	2.712E-02
5313100	I	1.118	1.700	1.444	1.798	9.067E-04	1.903E-03	2.809E-03	1.092E+07	4.049E-01	1.201E-02	2.519E-02	3.720E-02
5313200	I	.342	1.099	.797	.195	2.776E-04	1.184E-03	1.462E-03	1.182E+06	5.190E-04	3.676E-03	1.568E-02	1.936E-02
5413300	XE	.680	.394	.514	1.991	5.514E-04	4.408E-04	9.922E-04	1.209E+07	2.950E-01	7.301E-03	5.837E-03	1.314E-02
5614000	BA	6.354	3.563	4.736	6.762	5.153E-03	3.987E-03	9.140E-03	4.107E+07	2.423E+00	6.823E-02	5.280E-02	1.210E-01
5714000	LA	13.487	43.482	30.879	7.791	1.094E-02	4.866E-02	5.960E-02	4.726E+07	3.654E-01	1.448E-01	6.443E-01	7.892E-01
5814100	CE	5.526	1.800	3.346	10.335	4.482E-03	2.015E-03	6.496E-03	6.277E+07	9.417E+00	5.934E-02	2.668E-02	8.602E-02
5914300	PR	8.070	0.000	3.321	7.431	6.545E-03	0.	6.545E-03	4.514E+07	2.827E+00	8.667E-02	0.	8.667E-02
5814400	CE	1.038	.262	.598	3.733	8.420E-04	2.930E-04	1.135E-03	2.267E+07	2.974E+01	1.115E-02	3.880E-03	1.503E-02
5914400	PR	15.804	.281	6.804	3.733	1.282E-02	3.147E-04	1.313E-02	2.267E+07	1.255E-03	1.697E-01	4.168E-03	1.739E-01
6014700	ND	1.714	.610	1.074	2.115	1.390E-03	6.826E-04	2.072E-03	1.285E+07	6.511E-01	1.840E-02	9.038E-03	2.744E-02
6114700	PM	.107	.000	.045	.505	8.643E-05	1.372E-07	8.657E-05	3.065E+06	1.354E+01	1.144E-03	1.817E-06	1.146E-03

TABLE B-XVIII

TMI, UNIT 2, 22-STEP POWER HISTORY, FULL CORE CALC., CINDER-10(LASL) 7/79

39=TIME STEP
3.60000E+08=TOTAL TIME SINCE LAST TIME AT POWER(S)
3.29378E+07=TOTAL ELAPSED TIME(S)
8.26531E+19=FISSIONS/S AT LAST TS AT POWER. (22)
2.69970E+09=POWER (WATTS) AT LAST TS AT POWER (2.69970E+03 MW)
6.95228E+02=ACCUMULATED FISSIONS (FISSIONS PER BARN-CM)
1.39000E+03=TOTAL FP IN SUM PER BARN-CM

1.46128E+19=TOTAL ACTIVITY (DTS/S)
3.94940E+08=TOTAL CURIES
7.00679E-01=TOTAL BETA DECAY POWER (MW)
8.42795E-01=TOTAL GAMMA DECAY POWER (MW)
1.54347E+00=TOTAL DECAY POWER (MW)
5.29149E-02=TOTAL BETA MEV/F
6.36475E-02=TOTAL GAMMA MEV/F
1.16562E-01=TOTAL DECAY MEV/F

ID ZZAAAS	SYM	PERCENT OF ALL FP				MEV/FISS			CURIES	DENSITY	---DECAY POWER IN MW---		
		BETA	GAMMA	TOTAL	CURIES	BETA	GAMMA	TOTAL			BETA	GAMMA	TOTAL
3808900	SP	17.747	0.000	8.056	9.127	9.391E-03	0.	9.391E-03	3.604E+07	8.644E+00	1.243E-01	0.	1.243E-01
3909000	Y	.632	.000	.297	.203	3.346E-04	1.006E-07	3.347E-04	8.029E+05	9.887E-03	4.431E-03	1.333E-06	4.432E-03
3909100	Y	23.147	.084	10.554	11.432	1.225E-02	5.376E-05	1.230E-02	4.515E+07	1.220E+01	1.622E-01	7.119E-04	1.629E-01
4009500	ZR	4.995	26.286	16.620	12.355	2.643E-03	1.673E-02	1.937E-02	5.077E+07	1.534E+01	3.500E-02	2.215E-01	2.565E-01
4109500	NB	2.112	30.866	17.812	14.509	1.117E-03	1.965E-02	2.076E-02	5.730E+07	9.276E+00	1.480E-02	2.601E-01	2.749E-01
4410300	RU	1.593	9.608	5.970	7.059	8.428E-04	6.115E-03	6.958E-03	2.788E+07	5.092E+00	1.116E-02	8.098E-02	9.214E-02
4510310	RH	0.000	.781	.476	7.066	0.	4.969E-04	4.969E-04	2.791E+07	5.005E-03	0.	6.580E-03	6.580E-03
4510600	RU	.023	0.000	.010	.677	1.194E-05	0.	1.194E-05	2.675E+06	4.552E+00	1.581E-04	0.	1.581E-04
4510600	RH	3.271	.375	1.620	.677	1.731E-03	2.388E-04	1.970E-03	2.675E+06	4.269E-06	2.292E-02	3.162E-03	2.608E-02

5614000	RA	3.149	2.026	2.535	3.353	1.666E-03	1.289E-03	2.955E-03	1.328E+07	7.834E-01	2.206E-02	1.707E-02	3.913E-02
5714000	LA	6.654	24.723	16.914	3.870	3.537E-03	1.574E-02	1.927E-02	1.528E+07	1.182E-01	4.684E-02	2.084E-01	2.552E-01
5814100	CE	5.433	2.031	3.573	10.196	2.875E-03	1.292E-03	4.168E-03	4.027E+07	6.041E+00	3.807E-02	1.711E-02	5.518E-02
5914300	PR	4.271	0.000	1.939	3.946	2.260E-03	0.	2.260E-03	1.559E+07	9.761E-01	2.993E-02	0.	2.993E-02
5814400	CE	1.512	.434	.926	5.457	8.003E-04	2.785E-04	1.079E-03	2.155E+07	2.827E+01	1.060E-02	3.688E-03	1.429E-02
5914400	PR	23.022	.477	10.714	4.457	1.218E-02	2.992E-04	1.248E-02	2.155E+07	1.193E-03	1.613E-01	3.961E-03	1.653E-01
6014700	ND	.706	.294	.474	.874	3.735E-04	1.834E-04	5.569E-04	3.452E+06	1.750E-01	4.946E-03	2.429E-03	7.375E-03
6114700	PM	.167	.000	.076	.791	8.815E-05	1.399E-07	8.829E-05	3.126E+06	1.381E+01	1.167E-03	1.853E-06	1.169E-03

TABLE B-XIX

TME, UNIT 2, 22-STEP POWER HISTORY, FULL CORE CALC., CINDER-10(LASL) 7/79

40=TIME STEP
 7.20000E+05=TOTAL TIME SINCE LAST TIME AT POWER(S)
 3.65378E+07=TOTAL ELAPSED TIME(S)
 8.26531E+19=FISSIONS/S AT LAST TS AT POWER, (22)
 2.69970E+09=POWER (WATTS) AT LAST TS AT POWER (2.69970E+03 MW)
 6.95228E+02=ACCUMULATED FISSIONS (FISSIONS PER BARN-CM)
 1.38999E+03=TOTAL FP IN SUM PER BARN-CM

8.49797E+18=TOTAL ACTIVITY (DTS/S)
 2.29675E+08=TOTAL CURIES
 4.24262E-01=TOTAL BETA DECAY POWER (MW)
 4.49080E-01=TOTAL GAMMA DECAY POWER (MW)
 8.73342E-01=TOTAL DECAY POWER (MW)
 3.20401E-02=TOTAL BETA MEV/F
 3.39143E-02=TOTAL GAMMA MEV/F
 6.59543E-02=TOTAL DECAY MEV/F

ID ZZAAAS	SYM	PERCENT OF ALL FP				MEV/FISS			CURIES	DENSITY	---DECAY POWER IN MW---		
		BETA	GAMMA	TOTAL	CURIES	BETA	GAMMA	TOTAL					
3808900	SR	16.819	0.000	8.171	9.096	5.389E-03	0.	5.389E-03	2.068E+07	4.960E+00	7.136E-02	0.	7.136E-02
3909000	Y	1.041	.000	.506	.349	3.337E-04	1.004E-07	3.338E-04	8.007E+05	9.859E-03	4.419E-03	1.329E-06	4.420E-03
3909100	Y	23.353	.097	11.393	12.009	7.482E-03	3.284E-05	7.515E-03	2.758E+07	7.455E+00	9.908E-02	4.349E-04	9.951E-02
4009500	ZR	5.308	31.741	18.900	14.224	1.701E-03	1.076E-02	1.247E-02	3.267E+07	9.869E+00	2.252E-02	1.425E-01	1.651E-01
4109500	NR	2.392	48.040	26.174	20.697	9.267E-04	1.629E-02	1.722E-02	4.752E+07	7.693E+00	1.227E-02	2.157E-01	2.280E-01
4410300	RU	1.268	8.696	5.084	5.854	4.064E-04	2.949E-03	3.356E-03	1.344E+07	2.455E+00	5.382E-03	3.905E-02	4.443E-02
4510310	RH	0.000	.707	.363	5.859	0.	2.396E-04	2.396E-04	1.346E+07	2.414E-03	0.	3.173E-03	3.173E-03
4410600	RU	.034	0.000	.017	1.077	1.104E-05	0.	1.104E-05	2.473E+06	4.209E+00	1.462E-04	0.	1.462E-04
4510600	RH	4.995	.651	2.742	1.077	1.601E-03	2.208E-04	1.821E-03	2.473E+06	3.947E-06	2.119E-02	2.924E-03	2.412E-02
5613710	RA	0.000	.691	.355	.344	0.	2.343E-04	2.343E-04	7.904E+05	6.455E-06	0.	3.102E-03	3.102E-03
5614000	RA	.544	.397	.449	.605	1.742E-04	1.348E-04	3.090E-04	1.389E+06	8.191E-02	2.307E-03	1.785E-03	4.092E-03
5714000	LA	1.154	4.451	3.053	.496	7.698E-04	1.645E-03	2.015E-03	1.598E+06	1.235E-02	4.897E-03	2.179E-02	2.668E-02
5814100	CE	3.693	1.568	2.600	7.216	1.183E-03	5.319E-04	1.715E-03	1.657E+07	2.486E+00	1.567E-02	7.043E-03	2.271E-02
5914300	PR	.841	0.000	.479	.809	2.694E-04	0.	2.694E-04	1.858E+06	1.164E-01	3.568E-03	0.	3.568E-03
5814400	CE	2.257	.747	1.478	4.477	7.230E-04	2.516E-04	9.746E-04	1.947E+07	2.554E+01	9.574E-03	3.332E-03	1.291E-02
5914400	PR	34.350	.797	17.077	8.477	1.101E-02	2.703E-04	1.124E-02	1.947E+07	1.078E-03	1.457E-01	3.579E-03	1.493E-01
6114700	PM	.270	.000	.131	1.336	8.655E-05	1.374E-07	8.669E-05	3.069E+06	1.356E+01	1.146E-03	1.819E-06	1.148E-03

TABLE B-XX

TMI, UNIT 2, 22-STEP POWER HISTORY, FULL CORE CALC., CINDER-10(LASL) 7/79

41=TIME STEP
 1.80003F+07=TOTAL TIME SINCE LAST TIME AT POWER(S)
 4.73378E+07=TOTAL ELAPSED TIME(S)
 8.26531E+19=FISSIONS/S AT LAST TS AT POWER, (22)
 2.69970F+09=POWER (WATTS) AT LAST TS AT POWER (2.69970E+03 MW)
 6.95228E+02=ACCUMULATED FISSIONS (FISSIONS PER BARN-CM)
 1.38999E+03=TOTAL FP IN SIM PER BARN-CM

2.93655E+18=TOTAL ACTIVITY (DIS/S)
 7.93662E+07=TOTAL CURIES-
 1.87388E-01=TOTAL BETA DECAY POWER (MW)
 1.31923F-01=TOTAL GAMMA DECAY POWER (MW)
 3.19311E-01=TOTAL DECAY POWER (MW)
 1.41514E-02=TOTAL BETA MEV/F
 9.96273E-03=TOTAL GAMMA MEV/F
 2.41142E-02=TOTAL DECAY MEV/F

ID ZZAAAS	SYM	PERCENT OF ALL FP		ALL FP		MEV/FISS			CURIES	DENSITY	DECAY POWER IN MW		
		BETA	GAMMA	TOTAL	CURIES	BETA	GAMMA	TOTAL			BETA	GAMMA	TOTAL
3808900	SR	7.196	0.000	4.223	4.924	1.018E-03	0.	1.018E-03	3.908E+06	9.373E-01	1.348E-02	0.	1.348E-02
3809000	SR	.497	0.000	.222	1.070	7.035E-05	0.	7.035E-05	7.937E+05	3.757E+01	9.316E-04	0.	9.316E-04
3909000	Y	2.338	.001	1.373	1.070	3.309E-04	9.951E-08	3.310E-04	7.939E+05	9.777E-03	4.381E-03	1.318E-06	4.383E-03
3909100	Y	12.054	.075	7.135	7.923	1.706E-03	7.488E-06	1.713E-03	6.288E+06	1.699E+00	2.259E-02	9.915E-05	2.269E-02
4009500	ZR	3.201	29.744	13.771	10.955	4.530E-04	2.868E-03	3.321E-03	8.703E+06	2.629E+00	5.999E-03	3.797E-02	4.397E-02
4109500	NB	2.318	57.443	25.275	21.194	3.280E-04	5.767E-03	6.095E-03	1.682E+07	2.723E+00	4.343E-03	7.636E-02	8.070E-02
4410300	RU	.322	3.320	1.540	1.900	4.558E-05	3.307E-04	3.763E-04	1.508E+06	2.754E-01	6.035E-04	4.379E-03	4.983E-03
4510310	RH	0.000	.270	.111	1.902	0.	2.687E-05	2.687E-05	1.509E+06	2.707E-04	0.	3.559E-04	3.559E-04
4410600	RU	.062	0.000	.036	2.444	8.728E-06	0.	8.728E-06	1.956E+06	3.328E+00	1.156E-04	0.	1.156E-04
4510600	RH	8.943	1.753	5.977	2.454	1.266E-03	1.746E-04	1.440E-03	1.956E+06	3.121E-06	1.676E-02	2.312E-03	1.907E-02
5513400	CS	.056	.784	.357	.139	7.978E-06	7.814E-05	8.612E-05	1.105E+05	3.834E-01	1.056E-04	1.035E-03	1.140E-03
5513700	CS	.457	0.000	.258	1.044	6.473E-05	0.	6.473E-05	8.290E+05	4.203E+01	8.572E-04	0.	8.572E-04
5613710	BA	0.000	2.333	.964	.994	0.	2.325E-04	2.325E-04	7.842E+05	6.405E-06	0.	3.078E-03	3.078E-03
5814100	CE	.583	.372	.496	1.455	8.247E-05	3.708E-05	1.196E-04	1.155E+06	1.733E-01	1.092E-03	4.910E-04	1.583E-03
5814400	CE	3.767	1.462	2.940	18.088	5.331E-04	1.855E-04	7.187E-04	1.436E+07	1.883E+01	7.060E-03	2.457E-03	9.516E-03
5914400	PR	57.347	2.000	34.481	18.089	8.115E-03	1.993E-04	8.315E-03	1.436E+07	7.945E-04	1.075E-01	2.639E-03	1.101E-01
6114700	PM	.559	.001	.329	3.536	7.914E-05	1.256E-07	7.927E-05	2.806E+06	1.240E+01	1.048E-03	1.663E-06	1.050E-03

TABLE B-XXI

TMI, UNIT 2, 22-STEP POWER HISTORY, FULL CORE CALC., CINDER-10(LASL) 7/79

42=TIME STEP
 3.15360E+07=TOTAL TIME SINCE LAST TIME AT POWER(S)
 6.08738E+07=TOTAL ELAPSED TIME(S)
 8.26531E+19=FISSIONS/S AT LAST TS AT POWER, (22)
 2.69970E+09=POWER (WATTS) AT LAST TS AT POWER (2.69970E+03 MW)
 6.95228E+02=ACCUMULATED FISSIONS (FISSIONS PER BARN-CM)
 1.38998E+03=TOTAL FP IN SIM PER BARN-CM

1.31440E+18=TOTAL ACTIVITY (DTS/S)
 3.55244E+07=TOTAL CURIES
 1.05486E-01=TOTAL BETA DECAY POWER (MW)
 3.28596E-02=TOTAL GAMMA DECAY POWER (MW)
 1.38346E-01=TOTAL DECAY POWER (MW)
 7.96628E-03=TOTAL BETA MEV/F
 2.48154E-03=TOTAL GAMMA MEV/F
 1.04479E-02=TOTAL DECAY MEV/F

ID ZZAAAS	SYM	-----PERCENT OF ALL FP-----				-----MEV/FISS-----			CURIES	DENSITY	---DECAY POWER IN MW---		
		BETA	GAMMA	TOTAL	CURIES	BETA	GAMMA	TOTAL			BETA	GAMMA	TOTAL
3808900	SR	1.584	0.000	1.277	1.363	1.262E-04	0.	1.262E-04	4.842E+05	1.161E-01	1.671E-03	0.	1.671E-03
3809000	SR	.874	0.000	.656	2.211	6.961E-05	0.	6.961E-05	7.854E+05	3.718E+01	9.218E-04	0.	9.218E-04
3909000	Y	4.110	.004	3.135	2.211	3.274E-04	9.847E-05	3.275E-04	7.856E+05	9.674E-03	4.335E-03	1.304E-06	4.337E-03
3909100	Y	3.357	.047	2.571	2.775	2.674E-04	1.174E-06	2.686E-04	9.857E+05	2.664E-01	3.541E-03	1.554E-05	3.556E-03
4009500	ZR	1.084	27.019	6.056	4.664	8.632E-05	5.464E-04	6.327E-04	1.658E+06	5.009E-01	1.143E-03	7.235E-03	8.378E-03
4109500	NB	.853	44.171	12.072	9.815	6.799E-05	1.195E-03	1.263E-03	3.487E+06	5.644E-01	9.003E-04	1.583E-02	1.673E-02
4410300	RU	.037	.959	.732	.273	2.936E-06	2.131E-05	2.424E-05	9.713E+04	1.774E-02	3.888E-05	2.821E-04	3.210E-04
4410600	RU	.082	0.000	.052	4.172	6.503E-06	0.	6.503E-06	1.457E+06	2.480E+00	8.611E-05	0.	8.611E-05
4510600	RH	11.837	5.742	10.271	4.102	9.430E-04	1.301E-04	1.073E-03	1.457E+06	2.326E-06	1.249E-02	1.723E-03	1.421E-02
5513400	CS	.087	2.726	.713	.769	6.906E-06	6.764E-05	7.454E-05	9.564E+04	3.319E-01	9.145E-05	8.956E-04	9.871E-04
5513700	CS	.805	0.000	.613	2.311	6.410E-05	0.	6.410E-05	8.208E+05	4.162E+01	8.487E-04	0.	8.487E-04
5613710	BA	0.000	9.275	2.293	2.156	0.	2.302E-04	2.302E-04	7.765E+05	6.342E-06	0.	3.048E-03	3.048E-03
5814400	CE	4.568	5.104	4.675	27.585	3.639E-04	1.266E-04	4.906E-04	9.799E+06	1.285E+01	4.819E-03	1.677E-03	6.496E-03
5914400	PR	69.539	4.447	54.324	27.586	5.540E-03	1.360E-04	5.676E-03	9.800E+06	5.424E-04	7.335E-02	1.801E-03	7.516E-02
6114700	PM	.867	.005	.677	7.053	7.066E-05	1.122E-07	7.077E-05	2.505E+06	1.107E+01	9.356E-04	1.485E-06	9.371E-04

TABLE B-XXII

TMI, UNIT 2, 22-STEP POWER HISTORY, FULL CORE CALC., CINDER-10(LASL) 7/79

43=TIME STEP
 3.60000E+07=TOTAL TIME SINCE LAST TIME AT POWER(S)
 6.53378E+07=TOTAL ELAPSED TIME(S)
 8.26531E+19=FISSIONS/S AT LAST TS AT POWER (22)
 2.69970E+09=POWER (WATTS) AT LAST TS AT POWER (2.69970E+03 MW)
 6.95228E+02=ACCUMULATED FISSIONS (FISSIONS PER BARN-CM)
 1.38998E+03=TOTAL FP IN SUM PER BARN-CM

1.10263E+18=TOTAL ACTIVITY (DTS/S)
 2.98009E+07=TOTAL CURIES
 9.16321E-02=TOTAL BETA DECAY POWER (MW)
 2.23691E-02=TOTAL GAMMA DECAY POWER (MW)
 1.14001E-01=TOTAL DECAY POWER (MW)
 6.92002E-03=TOTAL BETA MEV/F
 1.68930E-03=TOTAL GAMMA MEV/F
 8.60932E-03=TOTAL DECAY MEV/F

ID ZZAAAS	SYM	-----PERCENT OF ALL FP-----				-----MEV/FISS-----			CURIES	DENSITY	---DECAY POWER IN MW---		
		BETA	GAMMA	TOTAL	CURIES	BETA	GAMMA	TOTAL			BETA	GAMMA	TOTAL
3808900	SR	.916	0.000	.736	.816	6.336E-05	0.	6.336E-05	2.432E+05	5.832E-02	8.390E-04	0.	8.390E-04
3809000	SR	1.002	0.000	.806	2.626	6.937E-05	0.	6.937E-05	7.826E+05	3.705E+01	9.186E-04	0.	9.186E-04

3909000	Y	4.715	.006	3.791	2.627	3.263E-04	9.812E-08	3.264E-04	7.828E+05	9.640E-03	4.320E-03	1.299E-06	4.322E-03
3909100	Y	2.097	.034	1.633	1.795	1.451E-04	6.370E-07	1.458E-04	5.350E+05	1.446E-01	1.922E-03	8.435E-06	1.930E-03
4009500	ZR	.722	19.722	4.254	3.221	4.997E-05	3.163E-04	3.662E-04	9.598E+05	2.900E-01	6.616E-04	4.188E-03	4.850E-03
4109500	NR	.574	41.347	9.475	6.837	3.973E-05	6.985E-04	7.382E-04	2.037E+06	3.298E-01	5.261E-04	9.249E-03	9.775E-03
4410300	RU	.017	.511	.114	.132	1.189E-06	8.625E-06	9.814E-06	3.932E+04	7.181E-03	1.574E-05	1.142E-04	1.299E-04
4410600	RH	.085	0.000	.059	4.437	5.902E-06	0.	5.902E-06	1.322E+06	2.250E+00	7.815E-05	0.	7.815E-05
4510600	RH	12.366	6.988	11.311	4.437	8.557E-04	1.181E-04	9.738E-04	1.322E+06	2.110E-06	1.133E-02	1.563E-03	1.289E-02
5513400	CS	.095	3.818	.876	.704	6.585E-06	6.449E-05	7.108E-05	9.120E+04	3.165E-01	8.720E-05	8.540E-04	9.412E-04
5513700	CS	.923	0.000	.742	2.745	6.389E-05	0.	6.389E-05	8.181E+05	4.148E+01	8.460E-04	0.	8.460E-04
5613710	BA	0.000	13.581	2.655	2.597	0.	2.294E-04	2.294E-04	7.740E+05	6.321E-06	0.	3.038E-03	3.038E-03
5814400	CF	4.637	6.610	5.024	28.993	3.209E-04	1.117E-04	4.325E-04	8.640E+06	1.133E+01	4.249E-03	1.479E-03	5.727E-03
5914400	PR	70.581	7.107	59.125	28.993	4.884E-03	1.199E-04	5.004E-03	8.640E+06	4.782E-04	6.468E-02	1.588E-03	6.626E-02
6114700	PM	.984	.006	.792	8.099	6.807E-05	1.080E-07	6.817E-05	2.414E+06	1.066E+01	9.013E-04	1.431E-06	9.027E-04

TABLE B-XXIII

TMI, UNIT 2, 22-STEP POWER HISTORY, FULL CORE CALC., CINDER-10(LASL) 7/79

44=TIME STEP
 7.20000E+07=TOTAL TIME SINCE LAST TIME AT POWER(S)
 1.01338E+08=TOTAL ELAPSED TIME(S)
 8.26531E+19=FISSIONS/S AT LAST TS AT POWER (22)
 2.69970E+09=POWER (WATTS) AT LAST TS AT POWER (2.69970E+03 MW)
 6.95228E+02=ACCUMULATED FISSIONS (FISSIONS PER BARN-CM)
 1.38997E+03=TOTAL FP IN SUM PER BARN-CM

4.67316E+17=TOTAL ACTIVITY (DIS/S)
 1.26302E+07=TOTAL CURIES
 3.70253E-02=TOTAL BETA DECAY POWER (MW)
 5.69269E-03=TOTAL GAMMA DECAY POWER (MW)
 4.27180E-02=TOTAL DECAY POWER (MW)
 2.79614E-03=TOTAL BETA MFV/F
 4.29907E-04=TOTAL GAMMA MFV/F
 3.22604E-03=TOTAL DECAY MFV/F

ID	SYN	PERCENT OF ALL FP				MEV/FISS			---DECAY POWER IN MW---				
		BETA	GAMMA	TOTAL	CURIES	BETA	GAMMA	TOTAL	CURIES	DENSITY	BETA	GAMMA	TOTAL
3608500	KR	.335	.019	.293	.461	9.360E-06	8.329E-08	9.443E-06	8.344E+04	1.508E+00	1.239E-04	1.103E-06	1.250E-04
3809000	SR	2.412	0.000	2.091	6.023	6.745E-05	0.	6.745E-05	7.609E+05	3.602E+01	8.931E-04	0.	8.931E-04
3909000	Y	11.345	.022	9.836	6.026	3.172E-04	9.540E-08	3.173E-04	7.611E+05	9.373E-03	4.200E-03	1.263E-06	4.202E-03
4009500	ZR	.022	.895	.138	.092	6.078E-07	3.847E-06	4.455E-06	1.168E+04	3.527E-03	8.048E-06	5.094E-05	5.899E-05
4109500	NR	.018	2.004	.293	.199	4.906E-07	8.626E-06	9.116E-06	2.516E+04	4.073E-03	6.497E-06	1.142E-04	1.207E-04
4410600	RH	.096	0.000	.094	4.785	7.698E-06	0.	2.698E-06	6.045E+05	1.029E+00	3.573E-05	0.	3.573E-05
4510600	RU	13.992	17.555	13.870	4.786	3.912E-04	5.397E-05	4.452E-04	6.045E+05	9.649E-07	5.180E-03	7.147E-04	5.895E-03
5112500	SB	.042	1.434	.228	.241	1.185E-06	6.166E-06	7.351E-06	3.047E+04	1.401E-01	1.569E-05	8.165E-05	9.734E-05
5513400	CS	.160	10.277	1.571	.427	4.486E-06	4.394E-05	4.842E-05	6.213E+04	2.156E-01	5.940E-05	5.818E-04	6.412E-04
5513700	CS	2.226	0.000	1.929	6.310	6.223E-05	0.	6.223E-05	7.969E+05	4.041E+01	8.240E-04	0.	8.240E-04
5613710	BA	0.000	51.981	4.927	5.949	0.	2.235E-04	2.235E-04	7.539E+05	6.157E-06	0.	2.959E-03	2.959E-03
5814400	CE	4.157	9.408	4.856	24.778	1.162E-04	4.045E-05	1.567E-04	3.130E+06	4.105E+00	1.539E-03	5.356E-04	2.075E-03
5914400	PR	63.271	10.104	56.186	24.779	1.769E-03	4.344E-05	1.813E-03	3.130E+06	1.732E-04	2.343E-02	5.753E-04	2.400E-02
6114700	PM	1.801	.019	1.553	14.136	5.035E-05	7.992E-08	5.043E-05	1.785E+06	7.889E+00	6.667E-04	1.058E-06	6.678E-04
6315400	EU	.022	.736	.117	.045	6.251E-07	3.164E-06	3.789E-06	5.654E+03	8.185E-02	8.278E-06	4.189E-05	5.017E-05

TABLE B-XXIV

TMT, UNIT 7, 22-STEP POWER HISTORY, FULL CORE CALC., CINDER-10(LASL) 7/79

45=TIME STEP
 1.80000E+08=TOTAL TIME SINCE LAST TIME AT POWER(S)
 2.09338E+08=TOTAL ELAPSED TIME(S)
 8.26531E+19=FISSIONS/S AT LAST TS AT POWER (22)
 2.69970E+09=POWER (WATTS) AT LAST TS AT POWER (2.69970E+03 MW)
 6.95228E+02=ACCUMULATED FISSIONS (FISSIONS PER BARN-CM)
 1.38994E+03=TOTAL FP IM SUM PER BARN-CM

1.51650E+17=TOTAL ACTIVITY (DIS/S)
 4.09964E+06=TOTAL CURIES
 7.53402E-03=TOTAL BETA DECAY POWER (MW)
 3.11832E-03=TOTAL GAMMA DECAY POWER (MW)
 1.06523E-02=TOTAL DECAY POWER (MW)
 5.64966E-04=TOTAL BETA MEV/F
 2.35494E-04=TOTAL GAMMA MEV/F
 8.04460E-04=TOTAL DECAY MEV/F

ID	SYM	PERCENT OF ALL FP				MEV/FISS			CURIES	DENSITY	DECAY POWER IN MW		
		BETA	GAMMA	TOTAL	CURIES	BETA	GAMMA	TOTAL			BETA	GAMMA	TOTAL
3608300	KR	1.319	.029	.941	1.632	7.503E-06	6.677E-08	7.570E-06	6.689E+04	1.209E+00	9.936E-05	8.842E-07	1.002E-04
3809000	SR	10.894	0.070	7.723	17.042	6.199E-05	0.	6.199E-05	6.993E+05	3.310E+01	8.208E-04	0.	8.208E-04
3909000	Y	51.239	.037	36.250	17.067	2.915E-04	8.768E-08	2.916E-04	6.995E+05	8.614E-03	3.860E-03	1.161E-06	3.862E-03
4410600	RU	.045	0.000	.032	1.409	2.578E-07	0.	2.578E-07	5.777E+04	9.831E-02	3.414E-06	0.	3.414E-06
4510600	RH	6.571	2.190	5.288	1.409	3.738E-05	5.158E-06	4.254E-05	5.777E+04	9.220E-08	4.950E-04	6.829E-05	5.633E-04
5112500	SB	.087	1.099	.383	.312	4.969E-07	2.586E-06	3.083E-06	1.278E+04	5.877E-02	6.579E-06	3.424E-05	4.082E-05
5513400	CS	.249	9.499	1.923	.479	1.418E-06	1.389E-05	1.531E-05	1.964E+04	6.817E-02	1.878E-05	1.839E-04	2.027E-04
5513700	CS	10.109	0.000	7.150	17.970	5.752E-05	0.	5.752E-05	7.365E+05	3.735E+01	7.616E-04	0.	7.616E-04
5613710	BA	0.000	87.704	25.674	17.000	0.	2.065E-04	2.065E-04	6.968E+05	5.691E-06	0.	2.735E-03	2.735E-03
5814400	CE	.971	.816	.929	3.629	5.523E-06	1.922E-06	7.445E-06	1.487E+05	1.951E-01	7.313E-05	2.545E-05	9.858E-05
5914400	PR	14.776	.877	10.707	3.629	8.407E-05	2.065E-06	8.614E-05	1.487E+05	8.231E-06	1.113E-03	2.734E-05	1.141E-03
6114700	PM	3.582	.014	2.539	17.833	2.038E-05	3.235E-08	2.041E-05	7.227E+05	3.193E+00	2.699E-04	4.284E-07	2.703E-04
6315400	EU	.083	1.019	.357	.105	4.743E-07	2.400E-06	2.875E-06	4.290E+03	6.210E-02	6.281E-06	3.179E-05	3.807E-05

SPECIAL (LIMITED) PRINT
 ALL FISSION PRODUCTS HAVING BETA, GAMMA, BETA+GAMMA OR CURIES
 EXCEEDING .500 PERCENT OF VALUE FOR ALL PRODUCTS
 (CINDER-10 CALCULATION, ENDF/B4 DATA)

TABLE B-XXV

TMI-2 IF OPERATED 26K HRS AT 2772. MW CONT. CINDER-10(LASL) 8/79

22=TIME STEP

0. -TOTAL TIME SINCE LAST TIME AT POWER(S)
 9.34916E+07=TOTAL ELAPSED TIME(S)
 6.88811E+19=FISSIONS/S AT LAST TS AT POWER (22)
 2.77200E+09=POWER (WATTS) AT LAST TS AT POWER (2.77200E+03 MW)
 7.28678E+03=ACCUMULATED FISSIONS (FISSIONS PER BARN-CM)
 1.44045E+04=TOTAL FP IN SUM PER BARN-CM

3.98926E+20=TOTAL ACTIVITY (DIS/S)
 1.07818E+10=TOTAL CURIES
 6.52732E+01=TOTAL BETA DECAY POWER (MW)
 6.12379E+01=TOTAL GAMMA DECAY POWER (MW)
 1.26511E+02=TOTAL DECAY POWER (MW)
 5.91497E+00=TOTAL BETA MEV/F
 5.54930E+00=TOTAL GAMMA MEV/F
 1.14643E+01=TOTAL DECAY MEV/F

ID ZAAAS	SYM	PERCENT OF		ALL FP		MEV/FISS			CURIES	DENSITY	DECAY POWER IN MW		
		BETA	GAMMA	TOTAL	CURIES	BETA	GAMMA	TOTAL			BETA	GAMMA	TOTAL
3508900	BR	.666	.435	.555	.222	3.941E-02	2.417E-02	6.359E-02	2.392E+07	2.030E-05	4.349E-01	2.668E-01	7.017E-01
3608800	KR	.086	.918	.441	.354	5.103E-03	4.541E-02	5.051E-02	3.822E+07	2.056E-02	5.632E-02	5.011E-01	5.574E-01
3708800	RB	.738	.254	.504	.347	4.363E-02	1.412E-02	5.775E-02	3.900E+07	2.211E-03	4.814E-01	1.558E-01	6.372E-01
3808900	KR	.521	.973	.716	.429	3.083E-02	5.124E-02	8.207E-02	4.624E+07	4.680E-04	3.402E-01	5.655E-01	9.057E-01
3708900	RB	.424	1.114	.758	.467	2.511E-02	6.184E-02	8.695E-02	5.030E+07	2.449E-03	2.771E-01	6.824E-01	9.595E-01
3609000	KR	.491	.771	.526	.422	2.903E-02	4.277E-02	7.180E-02	4.552E+07	7.849E-05	3.203E-01	4.720E-01	7.923E-01
3709000	RB	.708	1.210	.951	.436	4.187E-02	6.716E-02	1.090E-01	4.699E+07	4.064E-04	4.620E-01	7.411E-01	1.203E+00
3609100	KR	.783	.234	.518	.310	4.633E-02	1.301E-02	5.934E-02	3.346E+07	1.554E-05	5.113E-01	1.435E-01	6.548E-01
3709100	RB	.746	1.629	1.173	.571	4.411E-02	9.037E-02	1.345E-01	6.156E+07	1.912E-04	4.868E-01	9.973E-01	1.484E+00
3809100	SR	.397	.451	.423	.627	2.349E-02	2.504E-02	4.853E-02	6.704E+07	1.221E-01	2.592E-01	2.763E-01	5.355E-01
3909100	Y	.383	.002	.199	.646	2.267E-02	9.951E-05	2.277E-02	6.964E+07	1.882E+01	2.502E-01	1.098E-03	2.513E-01
3709200	RB	1.675	.135	.930	.435	9.909E-02	7.486E-03	1.066E-01	5.332E+07	1.289E-05	1.093E+00	8.261E-02	1.176E+00
3809200	SR	.128	.947	.524	.678	7.549E-03	5.256E-02	6.011E-02	7.309E+07	3.806E-02	8.331E-02	5.800E-01	6.633E-01
3909200	Y	.978	.177	.790	.652	5.784E-02	9.805E-03	6.765E-02	7.354E+07	4.989E-02	6.383E-01	1.082E-01	7.465E-01
3709300	RB	.743	.552	.651	.374	4.394E-02	3.066E-02	7.460E-02	4.035E+07	1.249E-05	4.849E-01	3.383E-01	8.232E-01
3809300	SR	.890	1.149	1.011	.783	5.263E-02	6.323E-02	1.159E-01	8.439E+07	2.027E-03	5.808E-01	6.978E-01	1.279E+00
3909300	Y	.937	.776	.720	.928	5.544E-02	4.193E-03	5.964E-02	8.714E+07	1.708E-01	6.118E-01	4.627E-02	6.581E-01
3709400	RB	.561	.393	.490	.190	3.317E-02	2.183E-02	5.501E-02	2.052E+07	2.946E-06	3.661E-01	2.409E-01	6.070E-01
3809400	SR	.657	1.000	.823	.771	3.884E-02	5.549E-02	9.433E-02	8.314E+07	3.355E-04	4.286E-01	6.123E-01	1.041E+00
3909400	Y	1.448	.896	1.176	.851	8.564E-02	4.917E-02	1.349E-01	9.283E+07	5.649E-03	9.450E-01	5.428E-01	1.488E+00
3809500	SR	1.300	.972	1.141	.684	7.687E-02	5.396E-02	1.308E-01	7.379E+07	1.024E-04	8.483E-01	5.955E-01	1.444E+00
3909500	Y	1.562	.446	1.031	.914	9.239E-02	2.584E-02	1.182E-01	9.852E+07	3.313E-03	1.020E+00	2.852E-01	1.305E+00
4009500	ZR	.109	.733	.411	.954	6.426E-03	4.067E-02	4.710E-02	1.029E+08	3.108E+01	7.091E-02	4.488E-01	5.198E-01
4109500	NB	.041	.775	.396	.969	2.445E-03	4.299E-02	4.543E-02	1.045E+08	1.691E+01	2.698E-02	4.744E-01	5.013E-01
3809600	SR	.615	.543	.590	.465	3.638E-02	3.012E-02	6.650E-02	5.008E+07	1.069E-05	4.015E-01	3.324E-01	7.339E-01
3909600	Y	2.033	1.314	1.685	.862	1.203E-01	7.293E-02	1.932E-01	9.296E+07	6.848E-04	1.327E+00	8.048E-01	2.132E+00
3809700	SR	.539	.449	.496	.234	3.188E-02	2.494E-02	5.682E-02	2.526E+07	2.697E-07	3.519E-01	2.752E-01	6.271E-01
3909700	Y	1.550	.714	1.145	.732	9.166E-02	3.964E-02	1.313E-01	7.892E+07	4.676E-06	1.011E+00	4.374E-01	1.449E+00
4009700	ZR	.677	.185	.439	.978	4.003E-02	1.029E-02	5.032E-02	1.054E+08	3.402E-01	4.418E-01	1.135E-01	5.553E-01
4109700	NB	.453	.699	.722	.789	2.681E-02	3.879E-02	6.560E-02	1.067E+08	2.514E-02	2.959E-01	4.281E-01	7.240E-01
4109710	NB	0.000	.855	.317	.845	0.	3.634E-02	3.634E-02	9.110E+07	2.626E-04	0.	4.010E-01	4.010E-01
3909800	Y	1.411	1.027	1.225	.596	8.343E-02	5.697E-02	1.404E-01	5.460E+07	8.743E-07	9.207E-01	6.287E-01	1.549E+00

4009800	ZR	.853	.001	.441	.946	9.047E-02	5.595E-05	5.053E-02	1.042E+08	1.724E-04	5.570E-01	6.175E-04	5.576E-01
4109800	NR	1.807	.143	1.072	.999	1.069E-01	8.035E-03	1.149E-01	1.067E+08	1.594E-05	1.179E+00	6.867E-02	1.268E+00
3909900	Y	.579	.496	.534	.793	3.426E-02	2.697E-02	6.122E-02	3.049E+07	1.302E-06	3.780E-01	2.976E-01	6.756E-01
4009900	ZR	1.527	.797	1.173	.962	9.030E-02	4.423E-02	1.345E-01	1.037E+08	1.329E-05	9.965E-01	4.880E-01	1.484E+00
4109900	NR	1.506	.711	.879	1.010	9.910E-02	1.169E-02	1.008E-01	1.089E+08	8.142E-05	9.833E-01	1.290E-01	1.112E+00
4209900	NR	.403	.799	.309	1.071	2.386E-02	1.154E-02	3.540E-02	1.154E+08	1.465E+00	2.633E-01	1.273E-01	3.906E-01
4309910	TC	0.000	.138	.047	.924	0.	7.639E-03	7.639E-03	9.963E+07	1.153E-01	0.	8.430E-02	8.430E-02
4010000	ZR	.629	.574	.672	.870	3.714E-02	3.186E-02	6.900E-02	9.380E+07	3.555E-05	4.098E-01	3.516E-01	7.614E-01
4110000	NR	1.150	1.143	1.144	.970	6.801E-02	6.342E-02	1.314E-01	6.147E+07	7.875E-06	7.505E-01	6.998E-01	1.450E+00
4110010	NR	1.183	.913	1.074	.970	6.996E-02	4.509E-02	1.150E-01	6.147E+07	7.908E-06	7.720E-01	4.976E-01	1.270E+00
4010100	ZR	1.249	.194	.739	.931	7.385E-02	1.086E-02	8.471E-02	5.728E+07	1.009E-05	8.150E-01	1.198E-01	9.348E-01
4110100	NR	1.715	.317	1.039	.922	1.015E-01	1.762E-02	1.191E-01	9.939E+07	3.714E-05	1.120E+00	1.944E-01	1.314E+00
4210100	NO	.981	1.447	.928	.997	3.435E-02	8.004E-02	1.144E-01	1.075E+08	5.026E-03	3.791E-01	8.832E-01	1.262E+00
4310100	TC	.469	.350	.411	.997	2.772E-02	1.942E-02	4.715E-02	1.075E+08	4.891E-03	3.059E-01	2.143E-01	5.203E-01
4110200	NR	1.877	1.159	1.626	.771	1.110E-01	7.536E-02	1.864E-01	8.309E+07	1.331E-05	1.225E+00	8.316E-01	2.057E+00
4210200	NO	.293	0.000	.151	.947	1.733E-02	0.	1.733E-02	1.037E+08	3.686E-03	1.912E-01	0.	1.912E-01
4310200	TC	1.423	.446	.940	.963	8.415E-02	2.587E-02	1.109E-01	1.038E+08	2.937E-05	9.286E-01	2.854E-01	1.214E+00
4110300	NR	.942	.799	.873	.954	5.571E-02	4.435E-02	1.001E-01	5.972E+07	4.995E-05	6.147E-01	4.894E-01	1.104E+00
4210300	NO	1.769	1.027	1.149	.992	7.505E-02	5.673E-02	1.318E-01	1.069E+08	3.425E-04	8.282E-01	6.260E-01	1.454E+00
4310300	TC	.712	.594	.627	1.011	4.209E-02	2.976E-02	7.185E-02	1.090E+08	2.909E-04	4.645E-01	3.284E-01	7.928E-01
4410300	RU	.067	.814	.796	1.014	3.965E-03	2.877E-02	3.274E-02	1.093E+08	1.996E+01	4.376E-02	3.175E-01	3.613E-01
4510310	RH	0.000	.047	.020	1.014	0.	2.336E-03	2.336E-03	1.093E+08	1.960E-02	0.	2.577E-02	2.577E-02
4110400	NR	.683	.577	.610	.737	4.039E-02	2.954E-02	6.993E-02	2.555E+07	1.364E-06	4.457E-01	3.260E-01	7.171E-01
4210400	NO	.405	.384	.375	.756	2.397E-02	2.133E-02	4.530E-02	8.146E+07	4.174E-04	2.645E-01	2.354E-01	4.999E-01
4310400	TC	.958	1.719	1.094	.820	5.664E-02	6.876E-02	1.254E-01	8.840E+07	5.096E-03	6.251E-01	7.588E-01	1.384E+00
4510400	RH	.713	.009	.372	.726	4.219E-02	4.834E-04	4.269E-02	7.832E+07	1.756E-04	4.656E-01	5.334E-03	4.710E-01
4210500	NO	.912	.789	.852	.947	5.392E-02	4.380E-02	9.773E-02	5.840E+07	1.683E-04	5.950E-01	4.834E-01	1.078E+00
4310500	TC	.717	.586	.653	.695	4.242E-02	3.250E-02	7.492E-02	7.495E+07	1.920E-03	4.681E-01	3.587E-01	8.267E-01
4410500	RU	.787	.584	.431	.710	1.697E-02	3.240E-02	4.938E-02	7.658E+07	6.534E-02	1.873E-01	3.576E-01	5.449E-01
4510500	RH	.100	.094	.078	.668	5.888E-03	3.046E-03	8.933E-03	7.198E+07	4.910E-01	6.497E-02	3.361E-02	9.858E-02
4310600	TC	.981	.733	.861	.439	5.804E-02	4.069E-02	9.873E-02	4.728E+07	9.338E-05	6.405E-01	4.490E-01	1.090E-01
4510600	RH	.603	.089	.354	.426	3.567E-02	4.921E-03	4.053E-02	4.594E+07	7.332E-05	3.936E-01	5.431E-02	4.479E-01
5113010	SR	.278	.823	.541	.259	1.642E-02	4.566E-02	6.208E-02	2.796E+07	3.313E-03	1.812E-01	5.038E-01	6.850E-01
5113100	SB	.334	.890	.594	.478	1.976E-02	4.714E-02	6.691E-02	5.155E+07	3.797E-03	2.181E-01	5.202E-01	7.383E-01
5213100	TF	.340	.228	.296	.517	2.010E-02	1.269E-02	3.275E-02	5.571E+07	4.460E-03	2.218E-01	1.396E-01	3.614E-01
5313100	I	.108	.241	.172	.593	6.369E-03	1.337E-02	1.973E-02	6.392E+07	2.370E+00	7.028E-02	1.475E-01	2.178E-01
5113200	SB	.475	.590	.531	.292	2.810E-02	3.274E-02	6.084E-02	3.037E+07	2.043E-04	3.101E-01	3.613E-01	6.713E-01
5213200	TE	.049	.236	.139	.860	2.922E-03	1.307E-02	1.599E-02	9.058E+07	1.358E+00	3.224E-02	1.442E-01	1.765E-01
5313200	I	.440	1.999	1.135	.854	2.601E-02	1.109E-01	1.370E-01	9.230E+07	4.053E-02	2.871E-01	1.224E+00	1.511E+00
5113300	SB	.163	.807	.475	.309	9.625E-03	4.480E-02	5.442E-02	3.336E+07	2.564E-04	1.062E-01	4.944E-01	6.006E-01
5213300	TE	.539	.689	.611	.671	3.186E-02	3.820E-02	7.009E-02	7.232E+07	2.895E-03	3.515E-01	4.215E-01	7.731E-01
5213310	TE	.220	.794	.438	.408	1.303E-02	4.406E-02	5.709E-02	4.395E+07	7.798E-03	1.438E-01	4.862E-01	6.300E-01
5313300	I	.487	.737	.605	1.179	2.848E-02	4.089E-02	6.937E-02	1.271E+08	5.081E-01	3.143E-01	4.512E-01	7.656E-01
5413300	XE	.119	.101	.110	1.192	7.035E-03	5.624E-03	1.266E-02	1.286E+08	3.137E+00	7.764E-02	6.206E-02	1.397E-01
5213400	TE	.128	.738	.423	.859	7.554E-03	4.098E-02	4.853E-02	9.247E+07	1.244E-02	8.336E-02	4.522E-01	5.356E-01
5313400	I	.854	3.415	2.074	1.262	5.051E-02	1.895E-01	2.409E-01	1.361E+08	2.293E-02	5.574E-01	2.092E+00	2.649E+00
5213500	TE	.715	1.021	.863	.449	4.230E-02	5.667E-02	9.897E-02	4.845E+07	4.656E-05	4.668E-01	6.254E-01	1.092E+00
5313500	I	.421	1.661	1.021	1.093	2.492E-02	9.218E-02	1.171E-01	1.179E+08	1.492E-01	2.750E-01	1.017E+00	1.292E+00
5313600	I	.875	1.140	1.073	.493	5.175E-02	6.325E-02	1.150E-01	5.320E+07	2.357E-04	9.711E-01	6.980E-01	1.269E+00
5313610	I	.547	.579	.547	.799	3.233E-02	3.711E-02	6.444E-02	3.104E+07	7.954E-05	3.568E-01	3.543E-01	7.111E-01
5313700	I	.715	1.020	.853	.492	4.228E-02	5.662E-02	6.890E-02	5.196E+07	6.823E-05	4.665E-01	6.248E-01	1.091E-01
5413700	XE	1.832	.207	1.046	1.017	1.084E-01	1.150E-02	1.199E-01	1.096E+08	1.348E-03	1.196E+00	1.269E-01	1.323E+00
5313800	I	.506	.686	.573	.243	2.991E-02	3.808E-02	6.800E-02	2.625E+07	9.107E-06	3.301E-01	4.203E-01	7.504E-01
5413800	XE	.599	1.180	.871	.930	3.544E-02	6.440E-02	9.984E-02	1.003E+08	4.562E-03	3.911E-01	7.106E-01	1.102E+00
5513800	CS	1.224	2.408	1.797	.991	7.242E-02	1.336E-01	2.060E-01	1.068E+08	1.101E-02	7.992E-01	1.474E+00	2.274E+00
5413900	XE	1.231	.681	.965	.704	7.282E-02	3.780E-02	1.106E-01	7.587E+07	1.636E-04	8.035E-01	4.171E-01	1.221E+00
5513900	CS	1.691	.318	1.076	.979	1.000E-01	1.763E-02	1.177E-01	1.056E+08	3.146E-03	1.104E+00	1.945E-01	1.299E+00
5613900	BA	.898	.056	.491	1.023	5.314E-02	3.097E-03	5.624E-02	1.103E+08	2.942E-02	5.864E-01	3.418E-02	6.206E-01
5414000	XE	.349	.642	.512	.451	2.303E-02	3.562E-02	5.864E-02	4.867E+07	3.533E-05	2.541E-01	3.930E-01	6.471E-01
5514000	CS	1.668	1.961	1.810	.882	9.864E-02	1.088E-01	2.075E-01	9.509E+07	3.238E-04	1.089E+00	1.201E+00	2.290E+00
5614000	BA	.272	.224	.249	.991	1.609E-02	1.245E-02	2.853E-02	1.069E+08	6.303E+00	1.775E-01	1.374E-01	3.149E-01

5714000	LA	.526	2.495	1.479	1.039	3.112E-02	1.385E-01	1.696E-01	1.121E+08	8.664E-01	3.435E-01	1.528E+00	1.871E+00
5514100	CS	.874	1.235	1.049	.649	5.172E-02	6.855E-02	1.203E-01	6.993E+07	9.332E-05	5.708E-01	7.564E-01	1.327E+00
5614100	BA	.844	.872	.897	.941	4.990E-02	4.840E-02	9.830E-02	1.015E+08	5.947E-03	5.507E-01	5.341E-01	1.085E+00
5714100	LA	.917	.032	.499	.946	5.425E-02	1.798E-03	5.605E-02	1.020E+08	7.588E-02	5.987E-01	1.984E-02	6.185E-01
5814100	CE	.148	.071	.111	.944	4.759E-03	3.938E-03	1.270E-02	1.022E+08	1.534E+01	9.666E-02	4.345E-02	1.401E-01
5514200	CS	.760	1.007	.990	.379	4.493E-02	5.591E-02	1.008E-01	4.090E+07	3.712E-06	4.938E-01	6.169E-01	1.113E+00
5614200	BA	.372	.976	.645	.886	2.198E-02	5.197E-02	7.394E-02	9.553E+07	3.274E-03	2.425E-01	5.735E-01	8.160E-01
5714200	LA	.844	2.280	1.539	.910	4.994E-02	1.266E-01	1.745E-01	9.816E+07	2.905E-02	5.511E-01	1.397E+00	1.948E+00
5614300	BA	.811	1.247	1.022	.741	4.799E-02	6.920E-02	1.172E-01	8.204E+07	5.957E-05	5.296E-01	7.637E-01	1.293E+00
5714300	LA	.696	1.018	.952	.855	4.118E-02	5.652E-02	9.770E-02	9.223E+07	4.135E-03	4.545E-01	6.237E-01	1.078E+00
5814300	CE	.352	.245	.310	.858	2.083E-02	1.470E-02	3.554E-02	9.254E+07	5.868E-01	2.299E-01	1.623E-01	3.922E-01
5914300	PR	.270	0.000	.140	.853	1.600E-02	0.	1.600E-02	9.193E+07	5.758E+00	1.765E-01	0.	1.765E-01
5614400	BA	.355	.517	.479	.560	2.102E-02	3.394E-02	5.495E-02	6.039E+07	3.546E-05	2.319E-01	3.745E-01	6.064E-01
5714400	LA	1.101	1.904	1.276	.744	6.512E-02	8.348E-02	1.486E-01	8.026E+07	1.714E-04	7.186E-01	9.213E-01	1.640E+00
5814400	CE	.064	.024	.045	.793	3.809E-03	1.326E-03	5.135E-03	8.548E+07	1.121E+02	4.203E-02	1.463E-02	5.666E-02
5914400	PR	.989	.024	.523	.820	9.849E-02	1.436E-03	5.992E-02	8.622E+07	4.772E-03	6.454E-01	1.585E-02	6.613E-01
5614500	BA	.375	.897	.493	.298	2.219E-02	3.315E-02	5.534E-02	3.211E+07	1.063E-05	2.449E-01	3.658E-01	6.107E-01
5714500	LA	.564	.883	.738	.564	3.333E-02	4.787E-02	8.120E-02	5.864E+07	9.078E-05	3.678E-01	5.282E-01	8.961E-01
5814500	CE	.363	.461	.411	.599	2.150E-02	2.556E-02	4.706E-02	6.354E+07	6.716E-04	2.373E-01	2.821E-01	5.193E-01
5914500	PR	.407	.009	.714	.590	2.406E-02	4.705E-04	2.453E-02	6.357E+07	7.305E-02	2.655E-01	5.192E-03	2.707E-01
5714600	LA	.618	.878	.744	.357	3.653E-02	4.872E-02	8.525E-02	3.847E+07	1.704E-05	4.031E-01	5.376E-01	9.407E-01
5914600	PR	.435	.817	.420	.479	2.572E-02	4.532E-02	7.104E-02	5.161E+07	4.000E-03	2.838E-01	5.001E-01	7.840E-01
5914800	PR	.603	.094	.357	.301	3.568E-02	5.238E-03	4.092E-02	3.251E+07	2.082E-04	3.938E-01	5.781E-02	4.516E-01

TABLE B-XXVI

THI-2 IF OPERATED 26K HRS AT 2772. MW CONT. CINER-10(LASL) 8/79

23=TIME STEP

1.00000E+00=TOTAL TIME SINCE LAST TIME AT POWER(S)
 9.34916E+07=TOTAL ELAPSED TIME(S)
 6.88811E+19=FISSIONS/S AT LAST TS AT POWER, (22)
 2.77200E+09=POWER (WATTS) AT LAST TS AT POWER (2.77200E+03 MW)
 7.28678E+03=ACCUMULATED FISSIONS (FISSIONS PER BARN-CM)
 1.44045E+04=TOTAL FP IN SIM PER BARN-CM

3.83448E+20=TOTAL ACTIVITY (DIS/S)
 1.03634E+10=TOTAL CURIES
 9.99576E+01=TOTAL BETA DECAY POWER (MW)
 5.71789E+01=TOTAL GAMMA DECAY POWER (MW)
 1.17136E+02=TOTAL DECAY POWER (MW)
 5.43328E+00=TOTAL BETA MEV/F
 5.18148E+00=TOTAL GAMMA MEV/F
 1.06148E+01=TOTAL DECAY MEV/F

ID	SYM	PERCENT OF ALL FP				MEV/FISS			CURIES	DENSITY	DECAY POWER IN MW		
		BETA	GAMMA	TOTAL	CURIES	BETA	GAMMA	TOTAL			BETA	GAMMA	TOTAL
3508800	BR	.698	.449	.577	.222	3.795E-02	2.327E-02	6.122E-02	2.303E+07	1.955E-05	4.187E-01	2.568E-01	6.755E-01
3608800	KR	.094	.876	.474	.369	5.103E-03	4.541E-02	9.051E-02	3.822E+07	2.056E-02	5.631E-02	5.011E-01	5.574E-01
3708900	RB	.803	.272	.544	.376	4.363E-02	1.412E-02	5.774E-02	3.900E+07	2.211E-03	4.814E-01	1.558E-01	6.372E-01
3608900	KR	.566	.987	.721	.445	3.075E-02	5.112E-02	8.187E-02	4.613E+07	4.668E-04	3.394E-01	5.641E-01	9.035E-01
3708900	RB	.462	1.193	.819	.485	2.511E-02	6.184E-02	8.695E-02	5.029E+07	2.448E-03	2.771E-01	6.824E-01	9.595E-01
3808900	SR	.301	0.000	.154	.504	1.633E-02	0.	1.633E-02	5.223E+07	1.253E+01	1.802E-01	0.	1.802E-01
3609000	KR	.525	.811	.645	.432	2.852E-02	4.202E-02	7.054E-02	4.473E+07	7.711E-05	3.147E-01	4.637E-01	7.784E-01

3709000	RB	.770	1.295	1.726	.453	4.184E-02	6.711F-02	1.089E-01	4.696E+07	4.061E-04	4.617E-01	7.405E-01	1.202E+00
3709010	RB	.553	.525	.334	.135	4.317E-03	2.718E-02	3.550E-02	1.400E+07	1.919E-04	9.178E-02	3.000E-01	3.918E-01
3609100	KR	.791	.233	.519	.330	4.300E-02	1.207E-02	5.505E-02	3.105E+07	1.442E-05	4.745E-01	1.332E-01	6.077E-01
3709100	RB	.907	1.734	1.240	.591	4.387E-02	8.986E-02	1.337E-01	6.121E+07	1.902E-04	4.841E-01	9.916E-01	1.476E+00
3809100	SR	.432	.483	.457	.647	2.349E-02	2.504E-02	4.853E-02	6.704E+07	1.221E-01	2.592E-01	2.763E-01	5.355E-01
3909100	Y	.417	.002	.215	.672	2.267E-02	9.931E-03	2.277E-02	6.964E+07	1.882E+01	2.502E-01	1.098E-03	2.513E-01
3709200	RB	1.634	.129	.829	.451	8.877E-02	6.707E-03	9.548E-02	4.777E+07	1.155E-05	9.796E-01	7.401E-02	1.054E+00
3809200	SR	.139	1.014	.544	.705	7.549E-03	5.256E-02	6.011E-02	7.309E+07	3.806E-02	8.331E-02	5.800E-01	6.633E-01
3909200	Y	1.065	.182	.637	.710	5.784E-02	9.805E-03	6.765E-02	7.354E+07	4.989E-02	6.383E-01	1.082E-01	7.465E-01
3709300	RB	.729	.533	.634	.351	3.961E-02	2.764E-02	6.725E-02	3.637E+07	1.126E-05	4.371E-01	3.050E-01	7.421E-01
3809300	SR	.968	1.219	1.071	.814	5.259E-02	6.318E-02	1.158E-01	8.432E+07	2.025E-03	5.803E-01	6.972E-01	1.278E+00
3909300	Y	1.020	.081	.542	.841	5.544E-02	4.193E-03	5.964E-02	8.714E+07	1.708E-01	6.118E-01	4.627E-02	6.581E-01
3809400	SR	.710	1.063	.892	.797	3.856E-02	5.509E-02	9.366E-02	8.255E+07	3.331E-04	4.255E-01	6.080E-01	1.034E+00
3909400	Y	1.576	.949	1.270	.896	8.563E-02	4.917E-02	1.348E-01	9.282E+07	5.649E-03	9.450E-01	5.426E-01	1.488E+00
3809500	SR	1.380	1.016	1.222	.694	7.497E-02	5.263E-02	1.276E-01	7.196E+07	9.988E-05	8.273E-01	5.807E-01	1.408E+00
3909500	Y	1.700	.499	1.114	.950	9.236E-02	2.584E-02	1.182E-01	9.850E+07	3.312E-03	1.019E+00	2.851E-01	1.304E+00
4009500	ZR	.118	.785	.444	.993	6.426E-03	4.067E-02	4.710E-02	1.029E+08	3.108E+01	7.091E-02	4.488E-01	5.198E-01
4109500	NB	.045	.890	.424	1.008	2.445E-03	4.299E-02	4.543E-02	1.045E+08	1.691E+01	2.698E-02	4.744E-01	5.013E-01
3809600	SR	.565	.420	.529	.408	3.070E-02	2.541E-02	5.611E-02	4.226E+07	9.023E-06	3.388E-01	2.804E-01	6.192E-01
3909600	Y	2.208	1.404	1.815	.895	1.200E-01	7.275E-02	1.927E-01	9.273E+07	6.831E-04	1.324E+00	8.028E-01	2.126E+00
3909700	Y	.964	.437	.707	.435	5.238E-02	2.265E-02	7.503E-02	4.510E+07	2.672E-06	5.780E-01	2.500E-01	8.280E-01
4009700	ZR	.737	.199	.474	1.017	4.003E-02	1.029E-02	5.032E-02	1.054E+08	3.402E-01	4.418E-01	1.135E-01	5.533E-01
4109700	NB	.493	.749	.618	1.029	2.681E-02	3.879E-02	6.560E-02	1.067E+08	2.514E-02	2.959E-01	4.281E-01	7.240E-01
4109710	NB	0.000	.701	.342	.879	0.	3.634E-02	3.634E-02	9.109E+07	2.626E-04	0.	4.010E-01	4.010E-01
4009800	ZR	.913	.001	.458	.988	4.963E-02	5.503E-05	4.969E-02	1.024E+08	1.695E-04	5.477E-01	6.072E-04	5.483E-01
4109800	NR	1.954	.154	1.075	1.022	1.061E-01	7.940E-03	1.141E-01	1.059E+08	1.583E-05	1.171E+00	8.806E-02	1.259E+00
4009900	ZR	1.328	.682	1.013	.870	7.217E-02	3.535E-02	1.075E-01	8.291E+07	1.062E-05	7.964E-01	3.901E-01	1.186E+00
4109900	NB	1.628	.224	.943	1.044	8.848E-02	1.161E-02	1.001E-01	1.082E+08	8.085E-05	9.764E-01	1.281E-01	1.104E+00
4209900	MD	.439	.223	.333	1.114	2.386E-02	1.154E-02	3.540E-02	1.154E+08	1.465E+00	2.633E-01	1.273E-01	3.906E-01
4309910	TC	0.000	.147	.022	.961	0.	7.639E-03	7.639E-03	9.963E+07	1.153E-01	0.	8.430E-02	8.430E-02
4010000	ZR	.626	.563	.525	.829	3.402E-02	2.919E-02	6.321E-02	8.594E+07	3.257E-05	3.754E-01	3.221E-01	6.975E-01
4110000	NB	1.165	1.140	1.153	.552	6.332E-02	5.904E-02	1.224E-01	5.723E+07	7.332E-06	6.988E-01	6.516E-01	1.350E+00
4110010	NB	1.200	.811	1.011	.553	6.523E-02	4.204E-02	1.073E-01	5.731E+07	7.373E-06	7.198E-01	4.640E-01	1.184E+00
4010100	ZR	1.117	.172	.454	.454	6.067E-02	8.921E-03	6.959E-02	4.706E+07	8.290E-06	6.695E-01	9.844E-02	7.679E-01
4110100	NB	1.783	.325	1.071	.916	9.690E-02	1.682E-02	1.137E-01	9.491E+07	3.547E-05	1.069E+00	1.857E-01	1.255E+00
4210100	MD	.632	1.544	1.078	1.037	3.435E-02	8.003E-02	1.144E-01	1.075E+08	5.026E-03	3.791E-01	8.832E-01	1.262E+00
4310100	TC	.510	.375	.444	1.038	2.772E-02	1.942E-02	4.715E-02	1.075E+08	4.891E-03	3.059E-01	2.143E-01	5.203E-01
4110200	NB	1.781	1.268	1.530	.699	9.674E-02	6.568E-02	1.624E-01	7.242E+07	1.160E-05	1.068E+00	7.248E-01	1.792E+00
4210200	MD	.319	0.000	.163	1.020	1.732E-02	0.	1.732E-02	1.036E+08	3.685E-03	1.911E-01	0.	1.911E-01
4310200	TC	1.548	.499	1.036	1.002	8.413E-02	2.586E-02	1.100E-01	1.038E+08	2.937E-05	9.284E-01	2.854E-01	1.214E+00
4110300	NB	.988	.824	.929	.454	5.370E-02	4.275E-02	9.645E-02	5.758E+07	4.816E-05	5.926E-01	4.718E-01	1.064E+00
4210300	MD	1.374	1.089	1.235	1.027	7.466E-02	5.643E-02	1.311E-01	1.064E+08	3.407E-04	8.239E-01	6.227E-01	1.447E+00
4310300	TC	.774	.574	.677	1.051	4.208E-02	2.975E-02	7.182E-02	1.090E+08	2.908E-04	4.643E-01	3.283E-01	7.926E-01
4410300	RU	.073	.555	.308	1.055	3.965E-03	2.877E-02	3.274E-02	1.093E+08	1.996E+01	4.376E-02	3.175E-01	3.613E-01
4510310	RH	0.000	.044	.022	1.055	0.	2.336E-03	2.336E-03	1.093E+08	1.960E-02	0.	2.577E-02	2.577E-02
4210400	MD	.439	.409	.424	.782	2.383E-02	2.121E-02	4.505E-02	8.101E+07	4.151E-04	2.630E-01	2.341E-01	4.971E-01
4310400	TC	1.042	1.327	1.191	.853	5.664E-02	6.876E-02	1.254E-01	8.839E+07	5.096E-03	6.251E-01	7.588E-01	1.384E+00
4510400	RH	.765	.009	.326	.744	4.155E-02	4.760E-04	4.203E-02	7.713E+07	1.729E-04	4.586E-01	5.253E-03	4.638E-01
4210500	MD	.981	.836	.910	.957	5.331E-02	4.331E-02	9.663E-02	5.774E+07	1.664E-04	5.883E-01	4.780E-01	1.066E+00
4310500	TC	.780	.627	.706	.723	4.240E-02	3.249E-02	7.489E-02	7.492E+07	1.920E-03	4.679E-01	3.585E-01	8.265E-01
4410500	RU	.312	.425	.465	.739	1.697E-02	3.240E-02	4.938E-02	7.658E+07	6.534E-02	1.873E-01	3.576E-01	5.449E-01
4510500	RH	.108	.059	.084	.695	5.888E-03	3.046E-03	8.933E-03	7.198E+07	4.910E-01	6.497E-02	3.361E-02	9.858E-02
4310600	TC	1.059	.779	.922	.452	5.754E-02	4.034E-02	9.789E-02	4.687E+07	9.257E-05	6.350E-01	4.452E-01	1.080E+00
4510600	RH	.655	.025	.382	.443	3.561E-02	4.913E-03	4.052E-02	4.586E+07	7.319E-05	3.930E-01	5.421E-02	4.472E-01
5113010	SB	.302	.881	.585	.279	1.642E-02	4.565E-02	6.207E-02	2.796E+07	3.313E-03	1.812E-01	5.038E-01	6.850E-01
5113100	SB	.364	.919	.630	.497	1.976E-02	4.713E-02	6.689E-02	5.153E+07	3.796E-03	2.180E-01	5.201E-01	7.381E-01
5213100	TE	.370	.244	.309	.537	2.010E-02	1.265E-02	3.275E-02	5.570E+07	4.460E-03	2.218E-01	1.396E-01	3.614E-01
5313100	I	.117	.259	.194	.617	6.369E-03	1.337E-02	1.973E-02	6.392E+07	2.370E+00	7.029E-02	1.475E-01	2.178E-01
5113200	SR	.515	.820	.571	.727	7.800E-02	3.262E-02	6.062E-02	3.027E+07	2.036E-04	3.090E-01	6.600E-01	6.690E-01
5213200	TE	.054	.252	.151	.874	2.922E-03	1.307E-02	1.599E-02	9.058E+07	1.358E+00	3.224E-02	1.442E-01	1.765E-01
5313200	I	.479	.214	1.220	.891	7.601E-02	1.109E-01	1.370E-01	9.230E+07	4.053E-02	2.871E-01	1.224E+00	1.511E+00
5113300	SR	.176	.841	.510	.320	9.583E-03	4.460E-02	5.419E-02	3.321E+07	2.553E-04	1.057E-01	4.922E-01	5.980E-01

5213300	TE	.586	.737	.650	.698	3.184E-02	3.819E-02	7.002E-02	7.229E+07	2.894E-03	3.514E-01	4.213E-01	7.727E-01
5213310	TE	.240	.850	.538	.424	1.303E-02	4.405E-02	5.708E-02	4.394E+07	7.797E-03	1.438E-01	4.861E-01	6.299E-01
5313300	I	.524	.780	.654	1.226	2.848E-02	4.089E-02	6.937E-02	1.271E+08	5.081E-01	3.143E-01	4.512E-01	7.656E-01
5413300	XE	.129	.107	.119	1.240	7.035E-03	5.624E-03	1.266E-02	1.286E+08	3.137E+00	7.764E-02	6.206E-02	1.397E-01
5213400	TE	.139	.791	.457	.892	7.552E-03	4.097E-02	4.852E-02	9.245E+07	1.244E-02	8.334E-02	4.521E-01	5.354E-01
5313400	I	.930	3.698	2.251	1.313	5.051E-02	1.895E-01	2.400E-01	1.361E+08	2.293E-02	3.574E-01	2.091E+00	2.649E+00
5213500	TE	.751	1.055	.890	.451	4.080E-02	5.466E-02	9.546E-02	4.674E+07	4.490E-05	4.502E-01	6.032E-01	1.053E+00
5313500	I	.459	1.779	1.133	1.137	7.492E-02	9.218E-02	1.171E-01	1.179E+08	1.491E-01	2.750E-01	1.017E+00	1.292E+00
5313600	I	.949	1.216	1.079	.511	5.153E-02	6.299E-02	1.145E-01	5.298E+07	2.347E-04	5.687E-01	6.951E-01	1.264E+00
5313610	I	.587	.611	.598	.295	3.187E-02	3.165E-02	6.352E-02	3.060E+07	7.840E-05	3.517E-01	3.492E-01	7.009E-01
5313700	I	.760	1.067	.910	.490	4.129E-02	5.530E-02	9.659E-02	5.075E+07	6.664E-05	4.557E-01	6.103E-01	1.066E+00
5413700	XE	1.992	.222	1.178	1.056	1.082E-01	1.148E-02	1.197E-01	1.094E+08	1.346E-03	1.194E+00	1.267E-01	1.321E+00
5313800	I	.500	.667	.592	.230	2.716E-02	3.458E-02	6.175E-02	2.384E+07	8.270E-06	2.998E-01	3.816E-01	6.814E-01
5413800	XE	.652	1.247	.940	.967	3.542E-02	6.436E-02	9.978E-02	1.003E+08	4.560E-03	3.909E-01	7.102E-01	1.101E+00
5513800	CS	1.333	2.579	1.941	1.030	7.242E-02	1.336E-01	2.060E-01	1.068E+08	1.101E-02	7.991E-01	1.474E+00	2.274E+00
5413900	XE	1.321	.719	1.027	.721	7.175E-02	3.725E-02	1.090E-01	7.476E+07	1.612E-04	7.918E-01	4.110E-01	1.203E+00
5513900	CS	1.841	.340	1.178	1.019	1.000E-01	1.762E-02	1.176E-01	1.056E+08	3.144E-03	1.104E+00	1.945E-01	1.298E+00
5613900	BA	.978	.060	.530	1.064	5.314E-02	3.097E-03	5.624E-02	1.103E+08	2.942E-02	3.864E-01	3.418E-02	6.206E-01
5414000	XE	.404	.695	.526	.447	2.193E-02	3.392E-02	5.584E-02	4.634E+07	3.364E-05	2.420E-01	3.743E-01	6.162E-01
5514000	CS	1.806	2.089	1.944	.913	9.811E-02	1.083E-01	2.064E-01	9.457E+07	3.221E-04	1.083E+00	1.195E+00	2.277E+00
5614000	BA	.296	.240	.269	1.031	1.609E-02	1.245E-02	2.853E-02	1.069E+08	6.303E+00	1.775E-01	1.374E-01	3.149E-01
5714000	LA	.573	2.672	1.578	1.081	3.112E-02	1.385E-01	1.696E-01	1.121E+08	8.664E-01	3.435E-01	1.528E+00	1.871E+00
5514100	CS	.931	1.294	1.178	.660	5.060E-02	6.705E-02	1.176E-01	6.840E+07	9.128E-05	5.583E-01	7.399E-01	1.298E+00
5614100	BA	.918	.934	.928	.979	4.989E-02	4.839E-02	9.828E-02	1.014E+08	5.946E-03	5.506E-01	5.339E-01	1.085E+00
5714100	LA	.998	.035	.528	.984	5.425E-02	1.798E-03	5.605E-02	1.020E+08	7.588E-02	5.987E-01	1.984E-02	6.185E-01
5814100	CE	.161	.076	.120	.987	8.759E-03	3.938E-03	1.270E-02	1.022E+08	1.534E-01	9.666E-02	4.345E-02	1.401E-01
5514200	CS	.585	.764	.672	.279	3.180E-02	3.957E-02	7.137E-02	2.895E+07	2.627E-06	3.509E-01	4.367E-01	7.876E-01
5614200	BA	.404	1.002	.696	.921	2.196E-02	5.193E-02	7.389E-02	9.546E+07	3.272E-03	2.424E-01	5.731E-01	8.154E-01
5714200	LA	.919	2.442	1.663	.947	4.994E-02	1.266E-01	1.765E-01	9.816E+07	2.905E-02	5.511E-01	1.397E+00	1.948E+00
5614300	BA	.848	1.283	1.050	.760	4.609E-02	6.645E-02	1.125E-01	7.880E+07	5.720E-05	5.086E-01	7.333E-01	1.242E+00
5714300	LA	.758	1.091	.920	.890	4.118E-02	5.651E-02	9.769E-02	9.222E+07	4.135E-03	4.544E-01	6.236E-01	1.078E+00
5814300	CE	.383	.284	.339	.893	2.083E-02	1.470E-02	3.554E-02	9.254E+07	5.868E-01	2.299E-01	1.623E-01	3.922E-01
5914300	PR	.294	0.000	.191	.897	1.600E-02	0.	1.600E-02	9.193E+07	5.758E+00	1.765E-01	0.	1.765E-01
5614400	BA	.365	.618	.499	.550	1.984E-02	3.203E-02	5.187E-02	5.700E+07	3.347E-05	2.199E-01	3.535E-01	5.724E-01
5714400	LA	1.193	1.474	1.334	.771	6.482E-02	8.310E-02	1.479E-01	7.989E+07	1.706E-04	7.153E-01	9.170E-01	1.632E+00
5814400	CE	.070	.026	.048	.829	3.809E-03	1.326E-03	5.135E-03	8.548E+07	1.121E+02	4.203E-02	1.463E-02	5.666E-02
5914400	PR	1.076	.028	.545	.832	5.849E-02	1.436E-03	5.992E-02	8.622E+07	4.772E-03	6.454E-01	1.585E-02	6.613E-01
5614500	BA	.367	.574	.458	.278	1.992E-02	2.976E-02	4.968E-02	2.882E+07	9.540E-06	2.198E-01	3.284E-01	5.482E-01
5714500	LA	.607	.913	.756	.559	3.295E-02	4.732E-02	8.028E-02	5.798E+07	8.975E-05	3.637E-01	5.222E-01	8.859E-01
5814500	CE	.396	.493	.443	.613	2.149E-02	2.555E-02	4.705E-02	6.352E+07	6.714E-04	2.372E-01	2.820E-01	5.192E-01
5914500	PR	.443	.009	.211	.613	2.406E-02	4.705E-04	2.453E-02	6.357E+07	7.305E-02	2.655E-01	5.192E-03	2.707E-01
5714600	LA	.633	.886	.757	.350	3.442E-02	4.590E-02	8.032E-02	3.625E+07	1.606E-05	3.798E-01	5.065E-01	8.863E-01
5914600	PR	.473	.878	.649	.498	2.572E-02	4.532E-02	7.104E-02	5.160E+07	4.000E-03	2.838E-01	5.001E-01	7.840E-01
5814700	CE	.332	.519	.423	.380	1.802E-02	2.691E-02	4.493E-02	3.940E+07	1.472E-04	1.988E-01	2.970E-01	4.958E-01
5914800	PR	.656	.101	.385	.313	3.566E-02	5.235E-03	4.089E-02	3.248E+07	2.081E-04	3.935E-01	5.777E-02	4.513E-01

TABLE B-XXVII

TMI-? IF OPERATED 26K HRS AT 2772. MW CONT. CINDER-10(LASL) 8/79

24=TIME STEP
4.00000E+00=TOTAL TIME SINCE LAST TIME AT POWER(S)
9.34916E+07=TOTAL ELAPSED TIME(S)
6.89811E+19=FISSIONS/S AT LAST TS AT POWER,(22)
2.77200E+09=POWER (WATTS) AT LAST TS AT POWER (2.77200E+03 MW)
7.28678E+03=ACCUMULATED FISSIONS (FISSIONS PFR BARN-CM)
1.44045E+04=TOTAL FP IN SIM PFR BARN-CM

3.61232E+20=TOTAL ACTIVITY (DTS/S)
 9.76303E+09=TOTAL CURIES
 5.32319E+01=TOTAL BETA DECAY POWER (MW)
 5.22197E+01=TOTAL GAMMA DECAY POWER (MW)
 1.05452E+02=TOTAL DECAY POWER (MJ)
 4.82381E+00=TOTAL BETA MFV/F
 4.73208E+00=TOTAL GAMMA MFV/F
 9.55589E+00=TOTAL DECAY MFV/F

ID ZAAAS	SYM	PERCENT OF ALL FP		CURIES		MEV/FISS			CURIES	DENSITY	DECAY POWER IN MW		
		BETA	GAMMA	TOTAL	TOTAL	BETA	GAMMA	TOTAL			BETA	GAMMA	TOTAL
3508700	BR	.532	.439	.445	.229	2.568E-02	2.076E-02	4.644E-02	2.239E+07	6.668E-09	2.834E-01	2.291E-01	5.124E-01
3508800	BR	.696	.435	.566	.209	3.355E-02	2.058E-02	5.413E-02	2.036E+07	1.728E-05	3.702E-01	2.271E-01	5.973E-01
3608800	KR	.106	.950	.529	.391	9.103E-03	4.540E-07	5.051E-02	3.821E+07	2.056E-02	5.631E-02	5.010E-01	5.573E-01
3708800	RB	.904	.299	.604	.399	4.363E-02	1.412E-02	5.774E-02	3.900E+07	2.211E-03	4.814E-01	1.558E-01	6.372E-01
3608900	KR	.632	1.071	.850	.469	3.050E-02	9.069E-02	8.119E-02	4.574E+07	4.630E-04	3.366E-01	5.594E-01	8.960E-01
3708900	RB	.520	1.307	.910	.515	2.510E-02	6.183E-02	8.693E-02	5.028E+07	2.448E-03	2.770E-01	6.823E-01	9.593E-01
3808900	SR	.338	0.000	.171	.935	1.633E-02	0.	1.633E-02	5.223E+07	1.293E+01	1.802E-01	0.	1.802E-01
3609000	KR	.557	.937	.676	.432	2.688E-02	3.961E-02	6.650E-02	4.216E+07	7.269E-05	2.967E-01	4.371E-01	7.338E-01
3709000	RB	.865	1.414	1.137	.480	4.173E-02	6.693E-02	1.087E-01	4.683E+07	4.050E-04	4.605E-01	7.386E-01	1.199E+00
3709010	RB	.172	.477	.370	.143	8.283E-03	2.707E-02	3.536E-02	1.394E+07	1.911E-04	9.141E-02	2.988E-01	3.902E-01
3609100	KR	.704	.201	.455	.291	3.394E-02	9.526E-03	4.346E-02	2.451E+07	1.138E-05	3.745E-01	1.051E-01	4.796E-01
3709100	RB	.892	1.962	1.377	.619	4.302E-02	8.813E-02	1.312E-01	6.003E+07	1.865E-04	4.747E-01	9.726E-01	1.447E+00
3809100	SR	.487	.529	.508	.657	2.349E-02	2.504E-02	4.853E-02	6.704E+07	1.221E-01	2.592E-01	2.763E-01	5.355E-01
3909100	Y	.470	.002	.238	.713	7.267E-02	9.951E-05	2.277E-02	6.964E+07	1.882E+01	2.502E-01	1.098E-03	2.513E-01
3709200	RB	1.259	.097	.693	.335	6.071E-02	4.587E-03	6.530E-02	3.267E+07	7.900E-06	6.699E-01	5.062E-02	7.206E-01
3809200	SR	.156	1.111	.629	.749	7.548E-03	5.256E-02	6.010E-02	7.308E+07	3.806E-02	8.330E-02	5.800E-01	6.633E-01
3909200	Y	1.199	.207	.778	.753	5.784E-02	9.805E-03	6.765E-02	7.354E+07	4.989E-02	6.383E-01	1.082E-01	7.635E-01
3709300	RB	.586	.417	.572	.254	2.826E-02	1.972E-02	4.798E-02	2.595E+07	8.034E-06	3.119E-01	2.176E-01	5.295E-01
3809300	SR	1.087	1.331	1.208	.861	9.243E-02	6.300E-02	1.154E-01	8.407E+07	2.019E-03	5.786E-01	6.952E-01	1.274E+00
3909300	Y	1.149	.089	.624	.893	9.544E-02	4.193E-03	5.964E-02	8.714E+07	1.708E-01	6.118E-01	4.627E-02	6.581E-01
3809400	SR	.781	1.137	.957	.826	3.766E-02	5.380E-02	9.146E-02	8.061E+07	3.253E-04	4.156E-01	5.937E-01	1.009E+00
3909400	Y	1.779	1.039	1.410	.991	8.561E-02	4.916E-02	1.348E-01	9.280E+07	5.647E-03	9.448E-01	5.425E-01	1.487E+00
3809500	SR	1.435	1.027	1.233	.681	6.922E-02	4.860E-02	1.178E-01	6.645E+07	9.223E-05	7.639E-01	5.363E-01	1.300E+00
3909500	Y	1.913	.545	1.236	1.008	9.227E-02	2.581E-02	1.181E-01	9.840E+07	3.309E-03	1.018E+00	2.848E-01	1.303E+00
4009500	ZR	.133	.860	.493	1.054	6.426E-03	4.067E-07	4.710E-02	1.029E+08	3.108E+01	7.091E-02	4.488E-01	5.198E-01
4109500	NB	.051	.908	.475	1.070	2.445E-03	4.299E-02	4.543E-02	1.045E+08	1.691E+01	2.698E-02	4.744E-01	5.013E-01
3909600	Y	2.463	1.522	1.997	.941	1.188E-01	7.204E-02	1.908E-01	9.183E+07	6.765E-04	1.311E+00	7.950E-01	2.106E+00
4009700	ZR	.830	.217	.527	1.079	4.003E-02	1.029E-02	5.032E-02	1.054E+08	3.402E-01	4.417E-01	1.135E-01	5.553E-01
4109700	NB	.556	.820	.697	1.093	2.681E-02	3.879E-02	6.560E-02	1.067E+08	2.514E-02	2.959E-01	4.281E-01	7.240E-01
4109710	NB	0.000	.768	.390	.933	0.	3.634E-02	3.634E-02	9.108E+07	2.625E-04	0.	4.010E-01	4.010E-01
4009800	ZR	.964	.001	.447	.983	4.651E-02	5.157E-05	4.656E-02	9.600E+07	1.589E-04	5.133E-01	5.690E-04	5.138E-01
4109800	NB	2.123	.163	1.152	1.047	1.024E-01	7.699E-03	1.101E-01	1.022E+08	1.528E-05	1.130E+00	8.496E-02	1.215E+00
4009900	ZR	.674	.337	.517	.383	3.252E-02	1.993E-02	4.845E-02	3.736E+07	4.786E-06	3.589E-01	1.758E-01	5.346E-01
4104900	NB	1.715	.229	.979	1.036	8.271E-02	1.085E-02	9.356E-02	1.011E+08	7.558E-05	9.128E-01	1.197E-01	1.032E+00
4209900	MD	.495	.244	.370	1.182	2.386E-02	1.154E-02	3.540E-02	1.154E+08	1.465E+00	2.633E-01	1.273E-01	3.906E-01
4309910	TC	0.000	.161	.090	1.020	0.	7.639E-03	7.639E-03	9.963E+07	1.193E-01	0.	8.430E-02	8.430E-02
4010000	ZR	.530	.464	.497	.662	2.558E-02	2.195E-02	4.753E-02	6.462E+07	2.449E-05	2.823E-01	2.422E-01	5.245E-01
4110000	NB	1.032	.291	1.077	.461	4.978E-02	4.641E-02	9.619E-02	4.499E+07	5.764E-06	5.493E-01	5.122E-01	1.061E+00
4110010	NB	1.071	.704	.889	.465	5.165E-02	3.329E-02	8.495E-02	4.539E+07	5.839E-06	5.700E-01	3.674E-01	9.374E-01
4010100	ZR	.680	.102	.394	.261	3.283E-02	4.877E-03	3.765E-02	2.546E+07	4.485E-06	3.622E-01	5.326E-02	4.155E-01
4110100	NB	1.681	.299	.976	.814	8.110E-02	1.408E-02	9.518E-02	7.944E+07	2.968E-05	8.949E-01	1.554E-01	1.050E+00
4210100	MD	.712	1.690	1.196	1.100	3.434E-02	7.999E-02	1.143E-01	1.074E+08	5.024E-03	3.789E-01	8.828E-01	1.262E+00
4310100	TC	.579	.410	.493	1.101	2.772E-02	1.942E-02	4.715E-02	1.075E+08	4.891E-03	3.059E-01	2.143E-01	5.203E-01
4110200	NB	1.415	.979	1.199	.523	6.825E-02	4.634E-02	1.146E-01	5.109E+07	8.181E-06	7.531E-01	5.113E-01	1.264E+00
4210200	MD	.359	0.000	.191	1.060	1.730E-02	0.	1.730E-02	1.035E+08	3.680E-03	1.909E-01	0.	1.909E-01
4310200	TC	1.743	.544	1.150	1.062	8.407E-02	2.584E-02	1.099E-01	1.037E+08	2.935E-05	9.278E-01	2.852E-01	1.213E+00
4110300	NB	.986	.801	.834	.523	4.758E-02	3.788E-02	8.547E-02	5.102E+07	4.267E-05	5.251E-01	4.180E-01	9.431E-01

4210300	MD	1.522	1.177	1.349	1.072	7.342E-02	5.549E-02	1.289E-01	1.046E+08	3.350E-04	8.102E-01	6.123E-01	1.423E+00
4310300	TC	.471	.679	.751	1.115	4.202E-02	2.971E-02	7.173E-02	1.088E+08	2.904E-04	4.637E-01	3.279E-01	7.916E-01
4410300	RU	.082	.609	.749	1.120	3.965E-03	2.877E-02	3.274E-02	1.093E+08	1.996E+01	4.376E-02	3.175E-01	3.613E-01
4510310	RH	0.000	.049	.074	1.120	0.	2.336E-03	2.336E-03	1.093E+08	1.960E-02	0.	2.577E-02	2.577E-02
4210400	MD	.484	.449	.462	.814	2.337E-02	2.080E-02	4.417E-02	7.942E+07	4.070E-04	2.579E-01	2.295E-01	4.874E-01
4310400	TC	1.174	1.453	1.312	.905	5.663E-02	6.875E-02	1.254E-01	8.838E+07	5.095E-03	6.249E-01	7.586E-01	1.384E+00
4510400	RH	.923	.710	.420	.755	3.969E-02	4.567E-04	4.015E-02	7.368E+07	1.652E-04	4.380E-01	5.018E-03	4.431E-01
4210500	MD	1.066	.883	.975	.570	5.142E-02	4.177E-02	9.319E-02	5.568E+07	1.605E-04	5.674E-01	4.609E-01	1.028E+00
4310500	TC	.878	.686	.793	.767	4.236E-02	3.246E-02	7.481E-02	7.484E+07	1.918E-03	4.674E-01	3.582E-01	8.256E-01
4410500	RU	.352	.695	.517	.784	1.697E-02	3.240E-02	4.938E-02	7.658E+07	6.534E-02	1.873E-01	3.576E-01	5.449E-01
4510500	RH	.122	.066	.023	.737	5.888E-03	3.046E-03	8.933E-03	7.198E+07	4.910E-01	6.497E-02	3.361E-02	9.858E-02
4310600	TC	1.158	.828	.974	.466	5.585E-02	3.916E-02	9.501E-02	4.550E+07	8.986E-05	6.163E-01	4.321E-01	1.048E+00
4510600	RH	.735	.103	.427	.467	3.544E-02	4.889E-03	4.033E-02	4.564E+07	7.284E-05	3.911E-01	5.395E-02	4.450E-01
4410700	RU	.554	.115	.336	.412	2.671E-02	5.427E-03	3.214E-02	4.019E+07	5.406E-04	2.948E-01	5.988E-02	3.547E-01
4510800	RH	.550	.717	.399	.277	2.651E-02	1.028E-02	3.679E-02	2.700E+07	2.450E-05	2.926E-01	1.134E-01	4.060E-01
5113010	SB	.340	.964	.649	.286	1.641E-02	4.564E-02	6.205E-02	2.795E+07	3.312E-03	1.811E-01	5.037E-01	6.848E-01
5113100	SB	.409	.925	.629	.927	1.974E-02	4.708E-02	6.687E-02	5.148E+07	3.793E-03	2.178E-01	5.196E-01	7.374E-01
5213100	TE	.417	.767	.343	.570	2.010E-02	1.265E-02	3.274E-02	5.569E+07	4.459E-03	2.218E-01	1.396E-01	3.613E-01
5313100	I	.132	.287	.277	.659	6.369E-03	1.337E-02	1.973E-02	6.392E+07	2.370E+00	7.028E-02	1.475E-01	2.178E-01
5113200	SB	.574	.427	.629	.307	2.770E-02	3.227E-02	5.997E-02	2.994E+07	2.014E-04	3.057E-01	3.561E-01	6.618E-01
5213200	TE	.061	.276	.157	.928	2.922E-03	1.307E-02	1.599E-02	9.058E+07	1.358E+00	3.224E-02	1.442E-01	1.765E-01
5313200	I	.539	2.344	1.433	.965	2.601E-02	1.109E-01	1.370E-01	9.230E+07	4.053E-02	2.871E-01	1.224E+00	1.511E+00
5113300	SB	.196	.930	.559	.336	9.451E-03	4.399E-02	5.344E-02	3.276E+07	2.518E-04	1.043E-01	4.854E-01	5.897E-01
5213300	TE	.659	.806	.737	.739	3.180E-02	3.913E-02	6.993E-02	7.220E+07	2.890E-03	3.509E-01	4.208E-01	7.717E-01
5213310	TE	.270	.920	.927	.450	1.302E-02	4.402E-02	5.704E-02	4.391E+07	7.792E-03	1.437E-01	4.858E-01	6.295E-01
5313300	I	.590	.864	.726	1.302	2.848E-02	4.089E-02	6.937E-02	1.271E+08	5.080E-01	3.143E-01	4.512E-01	7.656E-01
5413300	XE	.146	.119	.132	1.317	7.035E-03	5.624E-03	1.266E-02	1.286E+08	3.137E+00	7.764E-02	6.206E-02	1.397E-01
5213400	TE	.156	.865	.507	.946	7.546E-03	4.094E-02	4.848E-02	9.238E+07	1.243E-02	8.328E-02	4.510E-01	5.350E-01
5313400	I	1.047	4.005	2.512	1.394	5.050E-02	1.895E-01	2.400E-01	1.361E+08	2.292E-02	5.573E-01	2.091E+00	2.648E+00
5213500	TE	.756	1.033	.893	.428	3.648E-02	4.887E-02	8.534E-02	4.178E+07	4.015E-05	4.025E-01	5.393E-01	9.418E-01
5313500	I	.517	1.948	1.229	2.047	2.492E-02	9.218E-02	1.171E-01	1.179E+08	1.491E-01	2.750E-01	1.017E+00	1.292E+00
5313600	I	1.054	1.313	1.193	.535	5.085E-02	6.215E-02	1.130E-01	5.227E+07	2.316E-04	5.611E-01	6.858E-01	1.247E+00
5313610	I	.633	.640	.636	.300	3.052E-02	3.030E-02	6.092E-02	2.930E+07	7.507E-05	3.368E-01	3.344E-01	6.712E-01
5313700	I	.794	1.085	.938	.482	3.832E-02	5.132E-02	8.964E-02	4.710E+07	6.185E-05	4.229E-01	5.664E-01	9.82E-01
5413700	XE	2.232	.241	1.246	1.115	1.076E-01	1.142E-02	1.191E-01	1.089E+08	1.339E-03	1.188E+00	1.260E-01	1.314E+00
5313800	I	.416	.540	.477	.180	2.006E-02	2.554E-02	4.959E-02	1.760E+07	6.106E-06	2.213E-01	2.818E-01	5.031E-01
5413800	XE	.733	1.357	1.042	1.025	3.535E-02	6.423E-02	9.958E-02	1.001E+08	4.551E-03	3.901E-01	7.088E-01	1.099E+00
5513800	CS	1.501	2.823	2.156	1.094	7.241E-02	1.336E-01	2.060E-01	1.068E+08	1.101E-02	7.991E-01	1.474E+00	2.273E+00
5413900	XE	1.419	.751	1.098	.730	6.844E-02	3.553E-02	1.040E-01	7.131E+07	1.538E-04	7.553E-01	3.920E-01	1.147E+00
5513900	CS	2.071	.377	1.230	1.090	9.990E-02	1.760E-02	1.175E-01	1.054E+08	3.141E-03	1.102E+00	1.942E-01	1.297E+00
5613900	BA	1.102	.065	.589	1.129	5.314E-02	3.097E-03	5.624E-02	1.103E+08	2.942E-02	5.864E-01	3.418E-02	6.206E-01
5414000	XE	.391	.616	.532	.408	1.885E-02	2.915E-02	4.800E-02	3.984E+07	2.892E-09	2.080E-01	3.217E-01	5.297E-01
5514000	CS	1.998	2.248	2.122	.952	9.639E-02	1.064E-01	2.028E-01	9.292E+07	3.165E-04	1.064E+00	1.174E+00	2.237E+00
5614000	BA	.333	.263	.299	1.094	1.609E-02	1.245E-02	2.853E-02	1.069E+08	6.303E+00	1.775E-01	1.374E-01	3.149E-01
5714000	LA	.645	2.926	1.775	1.148	3.112E-02	1.385E-01	1.696E-01	1.121E+08	8.664E-01	3.435E-01	1.528E+00	1.871E+00
5514100	CS	.973	1.315	1.143	.690	4.695E-02	6.223E-02	1.092E-01	6.348E+07	8.471E-05	5.181E-01	6.867E-01	1.205E+00
5614100	BA	1.034	1.022	1.028	1.038	4.986E-02	4.835E-02	9.821E-02	1.014E+08	5.942E-03	5.502E-01	5.336E-01	1.084E+00
5714100	LA	1.125	.038	.917	1.045	5.425E-02	1.798E-03	5.605E-02	1.020E+08	7.587E-02	5.987E-01	1.984E-02	6.185E-01
5814100	CE	.182	.093	.133	1.047	8.759E-03	3.938E-03	1.270E-02	1.022E+08	1.534E+01	9.666E-02	4.345E-02	1.401E-01
5614200	BA	.454	1.095	.771	.975	2.190E-02	5.179E-02	7.370E-02	9.521E+07	3.263E-03	2.417E-01	5.716E-01	8.133E-01
5714200	LA	1.035	2.674	1.867	1.005	4.994E-02	1.265E-01	1.765E-01	9.816E+07	2.905E-02	5.510E-01	1.396E+00	1.948E+00
5614300	BA	.833	1.224	1.027	.704	4.018E-02	5.794E-02	9.812E-02	6.870E+07	4.988E-05	4.434E-01	6.394E-01	1.083E+00
5714300	LA	.853	1.194	1.022	.944	4.116E-02	5.648E-02	9.764E-02	9.217E+07	4.133E-03	4.542E-01	6.233E-01	1.078E+00
5814300	CE	.432	.311	.372	.944	2.083E-02	1.470E-02	3.554E-02	9.254E+07	5.868E-01	2.299E-01	1.223E-01	3.922E-01
5914300	PR	.332	0.000	.157	.962	1.600E-02	0.	1.600E-02	9.193E+07	5.758E+00	1.765E-01	0.	1.765E-01
5614400	BA	.342	.563	.452	.486	1.651E-02	2.666E-02	4.317E-02	4.744E+07	2.785E-05	1.822E-01	2.942E-01	4.763E-01
5714400	LA	1.320	1.775	1.521	.804	6.367E-02	8.163E-02	1.453E-01	7.848E+07	1.676E-04	7.027E-01	9.008E-01	1.604E+00
5814400	CE	.079	.028	.054	.875	3.809E-03	1.326E-03	5.135E-03	8.548E+07	1.121E+02	4.203E-02	1.463E-02	5.666E-02
5914400	PR	1.212	.030	.627	.883	9.848E-02	1.436E-03	5.992E-02	8.622E+07	4.772E-03	6.454E-01	1.585E-02	6.612E-01
5714500	LA	.656	.960	.807	.570	3.164E-02	4.543E-02	7.707E-02	5.566E+07	8.616E-05	3.491E-01	5.014E-01	8.505E-01

5814500	CE	.445	.539	.492	.690	2.147E-02	2.593E-02	4.700E-02	6.345E+07	6.706E-04	2.369E-01	2.817E-01	5.186E-01
5914500	PR	.499	.010	.297	.691	2.406E-02	4.705E-04	2.453E-02	6.357E+07	7.305E-02	2.655E-01	5.192E-03	2.707E-01
5714600	LA	.991	.789	.694	.392	2.801E-02	3.735E-02	6.536E-02	2.950E+07	1.307E-05	3.091E-01	4.122E-01	7.213E-01
5814600	CE	.139	.193	.151	.526	6.689E-03	8.663E-03	1.935E-02	5.131E+07	2.334E-03	7.382E-02	9.560E-02	1.694E-01
5914600	PR	.533	.998	.743	.529	2.572E-02	4.532E-02	7.104E-02	5.160E+07	4.000E-03	2.838E-01	5.001E-01	7.839E-01
5814700	CE	.367	.999	.452	.397	1.771E-02	2.645E-02	4.417E-02	3.873E+07	1.447E-04	1.955E-01	2.919E-01	4.874E-01
5914800	PR	.737	.110	.427	.332	3.558E-02	5.223E-03	4.080E-02	3.241E+07	2.076E-04	3.926E-01	5.763E-02	4.502E-01

TABLE B-XXVIII

TMI-2 IF OPERATED 26K HRS AT 2772. MW CONT. CINDER-10(LASL) 8/79

25=TIME STEP
 1.00000E+01=TOTAL TIME SINCE LAST TIME AT POWER(S)
 9.34917E+07=TOTAL ELAPSED TIME(S)
 6.88811E+19=FISSIONS/S AT LAST TS AT POWER (22)
 2.77200E+09=POWER (WATTS) AT LAST TS AT POWER (2.77200E+03 MW)
 7.28678E+03=ACCUMULATED FISSIONS (FISSIONS PER BARN-CM)
 1.44045E+04=TOTAL FP IN SUM PER BARN-CM

3.38753E+20=TOTAL ACTIVITY (DTS/S)
 9.15549E+09=TOTAL CURIES
 4.70729E+01=TOTAL BETA DECAY POWER (MW)
 4.77768E+01=TOTAL GAMMA DECAY POWER (MW)
 9.48497E+01=TOTAL DECAY POWER (MW)
 4.26569E+00=TOTAL BETA MEV/F
 4.32948E+00=TOTAL GAMMA MEV/F
 8.59516E+00=TOTAL DECAY MEV/F

ID ZZAAAS	SYM	-----PERCENT OF		ALL FP-----		-----MEV/FISS-----			CURIES	DENSITY	---DECAY POWER IN MW---		
		BETA	GAMMA	TOTAL	CURIES	BETA	GAMMA	TOTAL			BETA	GAMMA	TOTAL
3508700	RR	.567	.492	.599	.230	2.421E-02	1.957E-02	4.378E-02	2.110E+07	6.286E-05	2.671E-01	2.159E-01	4.831E-01
3508800	RR	.607	.367	.496	.172	2.590E-02	1.588E-02	4.179E-02	1.572E+07	1.334E-05	2.858E-01	1.753E-01	4.611E-01
3608900	KR	.120	1.049	.997	.417	7.102E-03	4.539E-02	5.049E-02	3.821E+07	2.056E-02	5.630E-02	5.009E-01	5.572E-01
3708900	RB	1.023	.326	.672	.426	4.362E-02	1.412E-02	5.774E-02	3.899E+07	2.211E-03	4.814E-01	1.558E-01	6.372E-01
3608900	KR	.701	1.149	.927	.490	2.992E-02	4.973E-02	7.965E-02	4.487E+07	4.542E-04	3.302E-01	5.488E-01	8.789E-01
3708900	RB	.588	1.427	1.011	.549	2.509E-02	6.180E-02	8.689E-02	5.026E+07	2.447E-03	2.769E-01	6.820E-01	9.588E-01
3808900	SR	.383	0.000	.190	.570	1.633E-02	0.	1.633E-02	5.223E+07	1.253E+01	1.802E-01	0.	1.802E-01
3609000	KR	.555	.806	.692	.406	2.368E-02	3.490E-02	5.858E-02	3.714E+07	6.404E-05	2.613E-01	3.851E-01	6.464E-01
3709000	RB	.971	1.535	1.755	.508	4.144E-02	6.646E-02	1.079E-01	4.651E+07	4.022E-04	4.572E-01	7.334E-01	1.191E+00
3709010	RB	.192	.670	.408	.151	8.210E-03	2.683E-02	3.504E-02	1.382E+07	1.894E-04	9.060E-02	2.961E-01	3.867E-01
3709100	RB	.961	1.941	1.459	.625	4.101E-02	8.402E-02	1.250E-01	5.723E+07	1.778E-04	4.526E-01	9.272E-01	1.380E+00
3809100	SR	.551	.579	.555	.732	2.349E-02	2.504E-02	4.853E-02	6.703E+07	1.221E-01	2.592E-01	2.763E-01	5.355E-01
3909100	Y	.531	.007	.255	.761	2.267E-02	9.951E-05	2.277E-02	6.964E+07	1.882E+01	2.502E-01	1.098E-03	2.513E-01
3709200	RB	.602	.045	.321	.151	2.566E-02	1.939E-03	2.760E-02	1.381E+07	3.340E-06	2.832E-01	2.140E-02	3.046E-01
3809200	SR	.177	1.214	.639	.799	7.546E-03	5.254E-02	6.009E-02	7.306E+07	3.805E-02	8.327E-02	5.798E-01	6.631E-01
3909200	Y	1.356	.226	.797	.803	5.784E-02	9.805E-03	6.765E-02	7.354E+07	4.989E-02	6.383E-01	1.082E-01	7.465E-01
3809300	SR	1.220	1.445	1.333	.912	5.206E-02	6.255E-02	1.146E-01	8.347E+07	2.005E-03	5.745E-01	6.902E-01	1.265E+00
3909300	Y	1.300	.097	.694	.952	5.544E-02	4.193E-03	5.964E-02	8.714E+07	1.708E-01	6.118E-01	4.627E-02	6.581E-01
3809400	SR	.838	1.179	1.710	.836	3.573E-02	5.105E-02	8.679E-02	7.650E+07	3.087E-04	3.943E-01	5.634E-01	9.577E-01
3909400	Y	2.006	1.135	1.557	1.013	8.556E-02	4.913E-02	1.347E-01	9.275E+07	5.644E-03	9.442E-01	5.422E-01	1.486E+00
3809500	SR	1.383	.957	1.159	.819	5.899E-02	4.141E-02	1.004E-01	5.663E+07	7.860E-05	6.510E-01	4.570E-01	1.108E+00
3909500	Y	2.158	.595	1.370	1.072	9.204E-02	2.575E-02	1.178E-01	9.816E+07	3.301E-03	1.016E+00	2.841E-01	1.300E+00

4009500	ZR	.151	.937	.544	1.124	6.426E-03	4.067E-02	4.710E-02	1.029E+08	3.108E+01	7.091E-02	4.488E-01	5.198E-01
4109500	NB	.037	.993	.479	1.141	2.445E-03	4.299F-02	4.543E-02	1.045E+08	1.691E+01	2.698E-02	4.744E-01	5.013E-01
3903600	Y	2.716	1.623	2.156	.978	1.159E-01	7.027E-02	1.861E-01	8.957E+07	6.598E-04	1.279E+00	7.754E-01	2.054E+00
4009700	ZR	.934	.729	.545	1.151	4.003E-02	1.029E-02	5.032E-02	1.054E+08	3.402E-01	4.417E-01	1.135E-01	5.552E-01
4109700	NB	.629	.876	.763	1.165	2.681E-02	3.879E-02	6.360E-02	1.067E+08	2.514E-02	2.959E-01	4.281E-01	7.239E-01
4109710	NB	0.000	.839	.423	.995	0.	3.633E-02	3.633E-02	9.107E+07	2.625E-04	0.	4.009E-01	4.009E-01
4009800	ZR	.954	.001	.474	.917	4.068E-02	4.510F-05	4.073E-02	8.396E+07	1.389E-04	4.489E-01	4.977E-04	4.494E-01
4109800	NB	2.150	.159	1.147	1.000	9.172E-02	6.895E-03	9.861E-02	9.154E+07	1.368E-05	1.012E+00	7.609E-02	1.088E+00
4109900	NB	1.525	.197	.855	.869	6.507E-07	8.536E-03	7.360E-02	7.956E+07	5.946E-05	7.180E-01	9.420E-02	8.122E-01
4209900	MD	.559	.268	.412	1.261	2.386E-02	1.154E-02	3.540E-02	1.154E+08	1.465E+00	2.633E-01	1.273E-01	3.906E-01
4309910	FC	0.000	.176	.099	1.088	0.	7.639E-03	7.639E-03	9.963E+07	1.153E-01	0.	8.430E-02	8.430E-02
4110000	NB	.679	.624	.651	.286	2.895E-02	2.700E-02	5.395E-02	2.617E+07	3.353E-06	3.195E-01	2.979E-01	6.174E-01
4110010	NB	.710	.451	.590	.291	3.029E-02	1.953F-02	4.982E-02	2.662E+07	3.424E-06	3.343E-01	2.155E-01	5.497E-01
4110100	NB	1.196	.705	.627	.544	5.101E-02	8.857E-03	5.987E-02	4.997E+07	1.867E-05	5.629E-01	9.774E-02	6.607E-01
4210100	MD	.803	1.844	1.329	1.171	3.427E-02	7.984E-02	1.141E-01	1.072E+08	5.014E-03	3.782E-01	8.811E-01	1.259E+00
4310100	TC	.650	.449	.549	1.175	7.772E-02	1.942E-02	4.715E-02	1.075E+08	4.891E-03	3.059E-01	2.143E-01	5.203E-01
4110200	NB	1.020	.697	.850	.356	4.349E-02	2.953E-02	7.302E-02	3.256E+07	5.214E-06	4.800E-01	3.259E-01	8.058E-01
4210200	MD	.404	0.000	.700	1.124	1.723E-02	0.	1.723E-02	1.031E+08	3.666E-03	1.902E-01	0.	1.902E-01
4310200	TC	1.966	.595	1.276	1.130	8.388E-02	2.578E-02	1.097E-01	1.035E+08	2.928E-05	9.256E-01	2.845E-01	1.210E+00
4110300	NB	.860	.679	.767	.430	3.670E-02	2.921E-02	6.591E-02	3.934E+07	3.291E-05	4.049E-01	3.224E-01	7.273E-01
4210300	MD	1.655	1.233	1.442	1.099	7.061E-02	5.337E-07	2.240E-01	1.006E+08	3.222E-04	7.792E-01	5.889E-01	1.368E+00
4310300	TC	.981	.683	.831	1.183	4.183E-02	2.957E-07	7.141E-02	1.083E+08	2.891E-04	4.616E-01	3.264E-01	7.880E-01
4410300	RU	.093	.665	.391	1.194	3.965E-03	2.877E-02	3.274E-02	1.093E+08	1.996E+01	4.376E-02	3.175E-01	3.613E-01
4510310	RH	0.000	.054	.027	1.194	0.	2.336E-03	2.336E-03	1.093E+08	1.960E-02	0.	2.577E-02	2.577E-02
4210400	MD	.525	.447	.472	.531	2.239E-02	1.993F-02	4.233E-02	7.611E+07	3.900E-04	2.471E-01	2.200E-01	4.671E-01
4310400	TC	1.327	1.587	1.458	.965	5.661E-02	6.871E-02	1.253E-01	8.834E+07	5.093E-03	6.247E-01	7.583E-01	1.383E+00
4510400	RH	.849	.010	.426	.735	3.624E-02	4.151E-04	3.665E-02	6.726E+07	1.508E-04	3.999E-01	4.581E-03	4.045E-01
4210500	MD	1.117	.894	1.075	.564	4.765E-02	3.871E-02	8.637E-02	5.161E+07	1.488E-04	5.259E-01	4.272E-01	9.531E-01
4310500	TC	.991	.749	.858	.815	4.225E-02	3.238E-02	7.463E-02	7.466E+07	1.913E-03	4.663E-01	3.573E-01	8.236E-01
4410500	RU	.398	.749	.574	.836	1.697E-02	3.740E-02	4.938E-02	7.658E+07	6.534E-02	1.873E-01	3.576E-01	5.449E-01
4510500	RH	.138	.070	.104	.788	5.888E-03	3.046E-03	8.933E-03	7.198E+07	4.910E-01	6.497E-02	3.361E-02	9.858E-02
4310600	TC	1.217	.841	1.079	.462	5.193E-02	3.641E-02	8.833E-02	4.230E+07	8.354E-05	5.730E-01	4.018E-01	9.748E-01
4510600	RH	.824	.112	.465	.494	3.513E-02	4.846E-03	3.997E-02	4.524E+07	7.220E-05	3.877E-01	5.348E-02	4.411E-01
4410700	RU	.621	.124	.371	.435	2.647E-02	5.377F-03	3.185E-02	3.982E+07	5.357E-04	2.921E-01	5.934E-02	3.515E-01
4510800	RH	.619	.236	.426	.294	2.639E-02	1.023E-02	3.662E-02	2.688E+07	2.439E-05	2.912E-01	1.129E-01	4.041E-01
5113010	SB	.385	1.754	.727	.305	1.640E-02	4.562F-02	6.202E-02	2.793E+07	3.310E-03	1.810E-01	5.034E-01	6.844E-01
5113100	SB	.462	1.088	.776	.561	1.970E-02	4.699E-02	6.669E-02	5.138E+07	3.785E-03	2.174E-01	5.185E-01	7.359E-01
5213100	TE	.471	.797	.391	.608	2.009E-02	1.264E-02	3.273E-02	5.568E+07	4.458E-03	2.217E-01	1.395E-01	3.612E-01
5313100	I	.149	.309	.730	.698	6.369E-03	1.337E-02	1.973E-02	6.392E+07	2.370E+00	7.028E-02	1.475E-01	2.178E-01
5113200	SA	.635	.729	.692	.320	2.709E-02	3.156E-02	5.865E-02	2.928E+07	1.970E-04	2.989E-01	3.483E-01	6.472E-01
5213200	TE	.068	.702	.196	.989	7.922E-03	1.307E-02	1.599E-02	9.058E+07	1.358E+00	3.224E-02	1.442E-01	1.765E-01
5313200	I	.610	2.567	1.533	1.008	2.601E-02	1.109E-01	1.370E-01	9.230E+07	4.053E-02	2.870E-01	1.224E+00	1.511E+00
5113300	SB	.215	.987	.624	.368	9.183E-03	4.274E-02	5.193E-02	3.183E+07	2.447E-04	1.013E-01	4.717E-01	5.730E-01
5213300	TE	.743	.879	.911	.786	3.171E-02	3.803E-02	6.974E-02	7.200E+07	2.883E-03	3.500E-01	4.197E-01	7.696E-01
5213310	TE	.305	1.014	.653	.479	1.301E-02	4.397E-02	5.697E-02	4.386E+07	7.782E-03	1.435E-01	4.852E-01	6.287E-01
5313300	I	.668	.944	.877	1.318	7.848E-02	4.089E-02	6.937E-02	1.271E+08	5.080E-01	3.143E-01	4.512E-01	7.655E-01
5413300	XE	.145	.130	.147	1.404	7.035E-03	5.624E-03	1.266E-02	1.286E+08	3.137E+00	7.764E-02	6.206E-02	1.397E-01
5213400	TE	.177	.944	.563	1.007	7.534E-03	4.087F-02	4.841E-02	9.223E+07	1.241E-02	8.314E-02	4.510E-01	5.342E-01
5313400	I	1.194	4.376	2.771	1.486	5.049E-02	1.894E-01	2.399E-01	1.360E+08	2.292E-02	5.571E-01	2.091E+00	2.648E+00
5213500	TE	.680	.897	.789	.363	2.900E-02	3.885F-02	6.744E-02	3.322E+07	3.192E-05	3.200E-01	4.287E-01	7.487E-01
5313500	I	.584	2.127	1.362	1.287	2.492E-02	9.217E-02	1.171E-01	1.178E+08	1.491E-01	2.750E-01	1.017E+00	1.292E+00
5313600	I	1.157	1.394	1.276	.554	4.937E-02	6.034E-02	1.097E-01	5.075E+07	2.248E-04	5.448E-01	6.659E-01	1.211E+00
5313610	I	.656	.647	.649	.293	2.799E-02	2.779E-02	5.377E-02	2.687E+07	6.884E-05	3.088E-01	3.067E-01	6.155E-01
5313700	I	.766	1.010	.889	.439	3.266E-02	4.375E-02	7.641E-02	4.015E+07	5.272E-05	3.604E-01	4.828E-01	8.432E-01
5413700	XE	2.496	.761	1.370	1.176	1.065E-01	1.129E-02	1.178E-01	1.077E+08	1.324E-03	1.175E+00	1.246E-01	1.299E+00
5413800	XE	.825	1.477	1.154	1.088	3.520E-02	6.396E-02	9.916E-02	9.964E+07	4.531E-03	3.884E-01	7.058E-01	1.094E+00
5513800	CS	1.697	3.085	2.397	1.166	7.240E-02	1.336E-01	2.068E+08	1.101E-02	7.990E-01	1.474E+00	2.273E+00	2.273E+00
5413900	XE	1.451	.747	1.074	.705	6.191E-02	3.214E-02	9.404E-02	8.450E+07	1.391E-04	6.832E-01	3.546E-01	1.038E+00
5513900	CS	2.336	.405	1.363	1.149	9.963E-02	1.756E-02	1.172E-01	1.052E+08	3.132E-03	1.099E+00	1.937E-01	1.293E+00
5613900	BA	1.246	.072	.654	1.204	5.314E-02	3.097F-03	5.624E-02	1.103E+08	2.941E-02	5.864E-01	3.417E-02	6.206E-01

5514000	CS	2.170	2.359	2.755	.974	9.255E-02	1.021E-01	1.947E-01	8.922E+07	3.038E-04	1.021E+00	1.127E+00	2.148E+00
5614000	BA	.377	.299	.732	1.167	1.609E-02	1.245E-02	2.853E-02	1.069E+08	6.303E+00	1.775E-01	1.374E-01	3.149E-01
5714000	LA	.730	3.199	1.973	1.224	3.112E-02	1.385E-01	1.696E-01	1.121E+08	8.664E-01	3.435E-01	1.528E+00	1.871E+00
5514100	CS	.935	1.221	1.079	.589	3.990E-02	5.288E-02	9.278E-02	5.395E+07	7.199E-05	4.403E-01	5.835E-01	1.024E+00
5614100	BA	1.167	1.115	1.141	1.106	4.978E-02	4.828E-02	9.805E-02	1.012E+08	5.933E-03	5.493E-01	5.327E-01	1.082E+00
5714100	LA	1.272	.042	.652	1.114	5.425E-02	1.798E-03	5.605E-02	1.020E+08	7.987E-02	5.987E-01	1.984E-02	6.185E-01
5814100	CE	.205	.071	.148	1.117	9.759E-03	3.938E-03	1.270E-02	1.022E+08	1.534E+01	9.665E-02	4.345E-02	1.401E-01
5614200	BA	.510	1.189	.852	1.034	2.177E-02	5.147E-02	7.324E-02	9.462E+07	3.243E-03	2.402E-01	5.680E-01	8.082E-01
5714200	LA	1.171	2.923	2.053	1.072	4.993E-02	1.265E-01	1.765E-01	9.816E+07	2.905E-02	5.510E-01	1.396E+00	1.947E+00
5614300	RA	.699	.993	.847	.557	7.981E-02	4.298E-02	7.279E-02	5.097E+07	3.700E-05	3.289E-01	4.743E-01	8.033E-01
5714300	LA	.763	1.302	1.134	1.005	4.109E-02	5.638E-02	9.747E-02	9.201E+07	4.126E-03	4.534E-01	6.222E-01	1.076E+00
5814300	CE	.488	.340	.413	1.011	2.083E-02	1.470E-02	3.554E-02	9.254E+07	5.868E-01	2.299E-01	1.623E-01	3.922E-01
5914300	PR	.375	0.000	.146	1.024	1.600E-02	0.	1.600E-02	9.193E+07	5.758E+00	1.765E-01	0.	1.765E-01
5714400	LA	1.419	1.793	1.477	.815	6.054E-02	7.762E-02	1.382E-01	7.462E+07	1.593E-04	6.681E-01	8.565E-01	1.525E+00
5814400	CE	.089	.031	.060	.934	3.809E-03	1.326E-03	5.135E-03	8.548E+07	1.121E+02	4.203E-02	1.463E-02	5.666E-02
5914400	PR	1.371	.033	.697	.942	5.848E-02	1.436E-03	5.992E-02	8.622E+07	4.772E-03	6.454E-01	1.585E-02	6.612E-01
5714500	LA	.669	.047	.939	.548	2.854E-02	4.099E-02	6.953E-02	5.022E+07	7.774E-05	3.150E-01	4.523E-01	7.673E-01
5814500	CE	.502	.988	.545	.691	2.140E-02	2.544E-02	4.683E-02	6.323E+07	6.683E-04	2.361E-01	2.807E-01	5.168E-01
5914500	PR	.564	.011	.295	.694	2.406E-02	4.705E-04	2.453E-02	6.357E+07	7.305E-02	2.655E-01	5.192E-03	2.707E-01
5714600	LA	.411	.540	.476	.702	1.752E-02	2.337E-02	4.089E-02	1.845E+07	8.176E-06	1.934E-01	2.579E-01	4.512E-01
5814600	CE	.156	.200	.178	.559	6.671E-03	8.640E-03	1.531E-02	5.118E+07	2.327E-03	7.362E-02	9.534E-02	1.690E-01
5914600	PR	.603	1.047	.826	.564	2.572E-02	4.532E-02	7.104E-02	5.160E+07	4.000E-03	2.838E-01	5.001E-01	7.839E-01
5814700	CE	.399	.587	.494	.405	1.702E-02	2.541E-02	4.243E-02	3.721E+07	1.390E-04	1.878E-01	2.804E-01	4.682E-01
5914800	PR	.829	.120	.472	.352	3.534E-02	5.189E-03	4.053E-02	3.220E+07	2.062E-04	3.900E-01	5.726E-02	4.473E-01

TABLE 8-XXIX

TMI-2 IF OPERATED 26K HRS AT 2772. MW CONT. CINDER-10(LASL) 8/79

26=TIME STEP
 4.00000E+01=TOTAL TIME SINCE LAST TIME AT POWER(S)
 9.34917E+07=TOTAL ELAPSED TIME(S)
 6.88811E+19=FISSIONS/S AT LAST TS AT POWER, (22)
 2.77200E+09=POWER (WATTS) AT LAST TS AT POWER (2.77200E+03 MW)
 7.28678E+03=ACCUMULATED FISSIONS (FISSIONS PER BARN-CM)
 1.44045E+04=TOTAL FP IN SIM PER BARN-CM

2.95022E+20=TOTAL ACTIVITY (DYS/S)
 7.97356E+09=TOTAL CURIES
 3.64390E+01=TOTAL BETA DECAY POWER (MW)
 3.94933E+01=TOTAL GAMMA DECAY POWER (MW)
 7.59323E+01=TOTAL DECAY POWER (MW)
 3.30206E+00=TOTAL BETA MFV/F
 3.57884E+00=TOTAL GAMMA MFV/F
 6.88089E+00=TOTAL DECAY MFV/F

ID	SYM	PERCENT OF ALL FP			MEV/FISS			DECAY POWER IN MW					
		BETA	GAMMA	TOTAL	BETA	GAMMA	TOTAL	BETA	GAMMA	TOTAL			
3508700	RR	.513	.393	.445	.185	1.694E-02	1.369E-02	3.063E-02	1.476E+07	4.398E-05	1.869E-01	1.511E-01	3.380E-01
3608700	KR	.578	.717	.442	.334	1.907E-02	1.133E-02	3.040E-02	2.661E+07	6.476E-03	2.105E-01	1.250E-01	3.355E-01
3608800	KR	.154	1.266	.733	.478	5.093E-03	4.532E-02	5.041E-02	3.815E+07	2.052E-02	5.621E-02	5.001E-01	5.563E-01
3708800	RB	1.321	.394	.839	.487	4.360E-02	1.411E-02	5.771E-02	3.898E+07	2.210E-03	4.812E-01	1.557E-01	6.369E-01
3608900	KR	.813	1.247	1.039	.505	7.586E-02	4.464E-02	7.150E-02	4.029E+07	4.077E-04	2.964E-01	4.927E-01	7.891E-01

3709900	RB	.757	1.721	1.258	.678	2.500E-02	6.158E-02	8.659E-02	5.009E+07	2.438E-03	2.759E-01	6.796E-01	9.555E-01
3808900	SR	.494	0.000	.717	.655	1.633E-02	0.	1.633E-02	5.223E+07	1.253E+01	1.802E-01	0.	1.802E-01
3809000	KR	.377	.512	.447	.245	1.244E-02	1.833E-02	3.078E-02	1.951E+07	3.365E-05	1.373E-01	2.023E-01	3.396E-01
3709000	RB	1.180	1.747	1.475	.549	3.897E-02	6.250E-02	1.015E-01	4.374E+07	3.787E-04	4.300E-01	6.898E-01	1.120E+00
3709010	RB	.235	.717	.492	.154	7.771E-03	2.540E-02	3.317E-02	1.308E+07	1.793E-04	8.575E-02	2.803E-01	3.660E-01
3709100	RB	.304	1.709	1.323	.522	2.986E-02	6.116E-02	9.102E-02	4.166E+07	1.294E-04	3.295E-01	6.749E-01	1.004E+00
3809100	SR	.711	.700	.735	.441	2.348E-02	2.504E-02	4.852E-02	6.702E+07	1.221E-01	2.592E-01	2.763E-01	5.354E-01
3909100	Y	.697	.003	.311	.473	2.267E-02	9.911E-05	2.277E-02	6.964E+07	1.882E+01	2.502E-01	1.098E-03	2.513E-01
3809200	SR	.228	1.465	.871	.014	7.531E-03	5.243E-02	5.995E-02	7.291E+07	3.797E-02	8.310E-02	5.786E-01	6.617E-01
3909200	Y	1.752	.274	.983	.922	5.784E-02	9.805E-03	6.765E-02	7.354E+07	4.989E-02	6.383E-01	1.082E-01	7.465E-01
3809300	SR	1.508	1.672	1.573	1.001	4.980E-02	5.984E-02	1.096E-01	7.985E+07	1.918E-03	5.496E-01	6.603E-01	1.210E+00
3909300	Y	1.679	.117	.867	1.093	5.544E-02	4.192E-03	5.963E-02	8.714E+07	1.708E-01	6.118E-01	4.626E-02	6.581E-01
3809400	SR	.823	1.084	.952	.729	2.716E-02	3.881E-02	6.597E-02	5.815E+07	2.347E-04	2.997E-01	4.282E-01	7.280E-01
3909400	Y	2.578	1.366	1.948	1.157	8.513E-02	4.888E-02	1.340E-01	9.228E+07	5.616E-03	9.395E-01	5.394E-01	1.479E+00
3809500	SR	.803	.520	.656	.319	2.651E-02	1.861E-02	4.512E-02	2.545E+07	3.532E-05	2.926E-01	2.054E-01	4.980E-01
3909500	Y	2.733	.705	1.678	1.207	9.024E-02	2.524E-02	1.155E-01	9.623E+07	3.236E-03	9.958E-01	2.785E-01	1.274E+00
4009500	ZR	.195	1.136	.644	1.290	6.426E-03	4.067E-02	4.710E-02	1.029E+08	3.108E+01	7.091E-02	4.488E-01	5.198E-01
4109500	NB	.074	1.201	.660	1.310	2.445E-03	4.299E-02	4.543E-02	1.045E+08	1.691E+01	2.698E-02	4.744E-01	5.013E-01
3909600	Y	3.027	1.874	2.334	.969	9.986E-02	6.062E-02	1.606E-01	7.727E+07	5.692E-04	1.103E+00	6.889E-01	1.772E+00
4009700	ZR	1.212	.287	.711	1.321	4.001E-02	1.028E-02	5.030E-02	1.053E+08	3.401E-01	4.416E-01	1.135E-01	5.551E-01
4109700	NB	.812	1.084	.953	1.338	2.681E-02	3.879E-02	6.560E-02	1.067E+08	2.514E-02	2.959E-01	4.281E-01	7.239E-01
4109710	NR	0.000	1.014	.929	1.141	0.	3.630E-02	3.630E-02	9.099E+07	2.623E-04	0.	4.006E-01	4.006E-01
4009800	ZR	.630	.001	.323	.328	2.080E-02	2.306E-05	2.082E-02	4.293E+07	7.104E-05	2.295E-01	2.545E-02	2.298E-01
4109800	NB	1.432	.092	.739	.592	4.728E-02	3.555E-03	5.084E-02	4.719E+07	7.053E-06	5.218E-01	3.923E-02	5.610E-01
4209900	MD	.722	.322	.514	1.448	2.386E-02	1.154E-02	3.539E-02	1.154E+08	1.465E+00	2.633E-01	1.273E-01	3.906E-01
4309910	TC	0.000	.323	.111	1.949	0.	7.639E-03	7.639E-03	9.963E+07	1.193E-01	0.	8.430E-02	8.430E-02
4210100	MD	1.017	2.187	1.626	1.318	3.359E-02	7.826E-02	1.119E-01	1.051E+08	4.915E-03	3.707E-01	8.637E-01	1.234E+00
4310100	TC	.929	.543	.485	1.348	2.772E-02	1.942E-02	4.713E-02	1.075E+08	4.889E-03	3.058E-01	2.143E-01	5.201E-01
4110200	NB	.545	.341	.423	.169	1.799E-02	1.221E-02	3.020E-02	1.346E+07	2.156E-06	1.985E-01	1.348E-01	3.332E-01
4210200	MD	.509	0.000	.244	1.241	1.681E-02	0.	1.681E-02	1.006E+08	3.575E-03	1.855E-01	0.	1.855E-01
4310200	TC	2.485	.705	1.552	1.270	8.205E-02	2.522E-02	1.073E-01	1.012E+08	2.864E-05	9.055E-01	2.783E-01	1.184E+00
4210300	MD	1.643	1.146	1.394	.969	5.424E-02	4.100E-02	9.524E-02	7.729E+07	2.475E-04	5.986E-01	4.524E-01	1.051E+00
4310300	TC	1.187	.774	.922	1.273	3.920E-02	2.771E-02	6.691E-02	1.015E+08	2.709E-04	4.325E-01	3.058E-01	7.383E-01
4410300	RU	.120	.804	.476	1.371	3.965E-03	2.877E-02	3.274E-02	1.093E+08	1.996E+01	4.376E-02	3.175E-01	3.613E-01
4510310	RH	0.000	.065	.024	1.371	0.	2.336E-03	1.093E+08	1.960E-02	0.	0.	2.577E-02	2.577E-02
4210400	MD	.546	.449	.425	.749	1.804E-02	1.605E-02	3.409E-02	6.131E+07	3.142E-04	1.990E-01	1.772E-01	3.762E-01
4310400	TC	1.707	1.912	1.813	1.103	5.636E-02	6.842E-02	1.248E-01	8.796E+07	5.071E-03	6.220E-01	7.550E-01	1.377E+00
4510400	RH	.703	.007	.341	.540	2.321E-02	2.659E-04	2.347E-02	4.307E+07	9.657E-05	2.961E-01	2.934E-03	2.590E-01
4210500	MD	.982	.726	.854	.440	3.243E-02	2.634E-02	5.877E-02	3.512E+07	1.012E-04	3.578E-01	2.907E-01	6.485E-01
4310500	TC	1.256	.888	1.055	.919	4.149E-02	3.179E-02	7.328E-02	7.331E+07	1.878E-03	4.578E-01	3.508E-01	8.087E-01
4410500	RU	.514	.905	.718	.960	1.697E-02	3.240E-02	4.938E-02	7.658E+07	6.534E-02	1.873E-01	3.576E-01	5.449E-01
4510500	RH	.178	.085	.110	.903	5.888E-03	3.046E-03	8.933E-03	7.198E+07	4.910E-01	6.497E-02	3.361E-02	9.858E-02
4310600	TC	.965	.624	.788	.326	3.187E-02	2.234E-02	5.421E-02	2.596E+07	5.127E-05	3.517E-01	2.465E-01	5.982E-01
4410600	RU	.007	0.000	.073	.534	2.279E-04	0.	2.279E-04	4.256E+07	7.243E+01	2.515E-03	0.	2.515E-03
4510600	RH	1.032	.131	.564	.551	3.409E-02	4.702E-03	3.879E-02	4.389E+07	7.006E-05	3.762E-01	5.189E-02	4.280E-01
4410700	RU	.758	.142	.437	.472	2.502E-02	5.082E-03	3.010E-02	3.764E+07	5.063E-04	2.761E-01	5.609E-02	3.322E-01
4510700	RH	.279	.191	.233	.510	9.206E-03	6.824E-03	1.603E-02	4.069E+07	2.828E-03	1.016E-01	7.530E-02	1.769E-01
4510800	RH	.763	.273	.428	.322	2.519E-02	9.764E-03	3.495E-02	2.565E+07	2.328E-05	2.780E-01	1.077E-01	3.857E-01
5113010	SB	.495	1.271	.828	.169	1.635E-02	4.547E-02	6.182E-02	2.785E+07	3.300E-03	1.804E-01	5.018E-01	6.822E-01
5113100	SB	.590	1.299	.759	.637	1.948E-02	4.648E-02	6.597E-02	5.083E+07	3.744E-03	2.150E-01	5.129E-01	7.280E-01
5213100	TE	.607	.353	.475	.492	2.005E-02	1.263E-02	3.264E-02	5.559E+07	4.451E-03	2.213E-02	1.393E-01	3.607E-01
5313100	I	.193	.323	.247	.802	6.369E-03	1.337E-02	1.973E-02	6.392E+07	2.370E+00	7.028E-01	1.475E-01	2.178E-01
5113200	SB	.726	.780	.754	.328	2.397E-02	2.793E-02	5.189E-02	2.591E+07	1.743E-04	2.645E-01	3.082E-01	5.727E-01
5113210	SE	.479	.531	.494	.218	1.581E-02	1.901E-02	3.452E-02	1.736E+07	2.279E-04	1.744E-01	2.097E-01	3.842E-01
5213200	TE	.088	.365	.232	1.136	2.922E-03	1.307E-02	1.599E-02	9.058E+07	1.358E+00	3.224E-02	1.442E-01	1.765E-01
5313200	I	.788	3.100	1.920	1.157	2.601E-02	1.109E-01	1.369E-01	9.229E+07	4.053E-02	2.870E-01	1.224E+00	1.511E+00
5113300	SB	.241	1.024	.453	.346	7.949E-03	3.700E-02	4.495E-02	2.755E+07	2.118E-04	8.771E-02	4.083E-01	4.960E-01
5213300	TE	.947	1.049	.999	.890	3.126E-02	3.749E-02	6.875E-02	7.098E+07	2.842E-03	3.450E-01	4.137E-01	7.587E-01
5213310	TE	.391	1.221	.823	.547	1.293E-02	4.370E-02	5.662E-02	4.359E+07	7.735E-03	1.427E-01	4.822E-01	6.249E-01
5313300	I	.963	1.143	1.028	1.524	2.848E-02	4.089E-02	6.937E-02	1.271E+08	5.080E-01	3.143E-01	4.512E-01	7.655E-01

5413300	XE	.213	.157	.194	1.419	7.035E-03	5.624E-03	1.266E-02	1.286E+08	3.137E+00	7.764E-02	6.206E-02	1.397E-01
5213400	TE	.226	1.133	.678	1.147	7.473E-03	4.054E-02	4.801E-02	9.148E+07	1.231E-02	8.247E-02	4.474E-01	5.298E-01
5313400	I	1.527	5.296	3.432	1.704	5.041E-02	1.892E-01	2.396E-01	1.358E+08	2.288E-02	5.563E-01	2.087E+00	2.644E+00
5313500	I	.754	2.571	1.770	1.477	2.490E-02	9.210E-02	1.170E-01	1.178E+08	1.490E-01	2.748E-01	1.016E+00	1.291E+00
5313600	I	1.241	1.407	1.324	.529	4.099E-02	5.010E-02	9.110E-02	4.214E+07	1.867E-04	4.524E-01	5.529E-01	1.005E+00
5313610	I	.550	.503	.574	.219	1.815E-02	1.802E-02	3.617E-02	1.742E+07	4.464E-05	2.002E-01	1.988E-01	3.991E-01
5313700	I	.427	.528	.479	.217	1.410E-02	1.888E-02	3.298E-02	1.733E+07	2.276E-05	1.556E-01	2.084E-01	3.640E-01
5413700	XE	3.012	.295	1.599	1.262	9.946E-02	1.055E-02	1.100E-01	1.006E+08	1.237E-03	1.098E+00	1.164E-01	1.214E+00
5413900	XE	1.041	1.749	1.477	1.270	3.438E-02	6.246E-02	9.684E-02	9.730E+07	4.425E-03	3.793E-01	6.893E-01	1.069E+00
5513800	CS	2.191	3.727	2.991	1.339	7.234E-02	1.335E-01	2.058E-01	1.067E+08	1.100E-02	7.983E-01	1.473E+00	2.271E+00
5413900	XE	1.121	.537	.817	.484	3.702E-02	1.927E-02	5.624E-02	3.857E+07	8.319E-05	4.086E-01	2.121E-01	6.206E-01
5513900	CS	2.960	.481	1.671	1.294	9.773E-02	1.722E-02	1.150E-01	1.032E+08	3.073E-03	1.079E+00	1.900E-01	1.269E+00
5613900	BA	1.609	.087	.817	1.342	5.313E-02	3.096E-03	5.622E-02	1.102E+08	2.941E-02	5.863E-01	3.417E-02	6.204E-01
5514000	CS	2.149	2.199	2.170	.899	7.098E-02	7.832E-02	1.493E-01	6.842E+07	2.330E-04	7.832E-01	8.643E-01	1.648E+00
5614000	BA	.487	.349	.415	1.340	1.609E-02	1.245E-02	2.853E-02	1.069E+08	6.303E+00	1.775E-01	1.374E-01	3.149E-01
5714000	LA	.943	3.869	2.455	1.406	3.112E-02	1.385E-01	1.696E-01	1.121E+08	8.664E-01	3.435E-01	1.528E+00	1.871E+00
5514100	CS	.526	.643	.597	.295	1.738E-02	2.303E-02	4.040E-02	2.349E+07	3.135E-05	1.917E-01	2.541E-01	4.459E-01
5614100	BA	1.489	1.333	1.409	1.244	4.918E-02	4.770E-02	9.688E-02	1.000E+08	5.862E-03	5.427E-01	5.264E-01	1.069E+00
5714100	LA	1.643	.050	.815	1.280	5.425E-02	1.798E-03	5.605E-02	1.020E+08	7.587E-02	5.986E-01	1.984E-02	6.185E-01
5814100	CE	.265	.110	.195	1.282	8.759E-03	3.938E-03	1.270E-02	1.022E+08	1.534E+01	9.666E-02	4.345E-02	1.401E-01
5614200	BA	.638	1.392	1.031	1.149	2.108E-02	4.983E-02	7.091E-02	9.161E+07	3.139E-03	2.326E-01	5.499E-01	7.825E-01
5714200	LA	1.512	2.525	2.564	1.231	4.992E-02	1.265E-01	1.764E-01	9.814E+07	2.904E-02	5.509E-01	1.396E+00	1.947E+00
5714300	LA	1.222	1.544	1.322	1.134	4.037E-02	5.540E-02	9.576E-02	9.040E+07	4.053E-03	4.455E-01	6.113E-01	1.057E+00
5814300	CE	.631	.411	.516	1.161	2.083E-02	1.470E-02	3.554E-02	9.254E+07	5.868E-01	2.299E-01	1.623E-01	3.922E-01
5914300	PR	.484	0.000	.232	1.153	1.600E-02	0.	1.609E-02	9.193E+07	5.758E+00	1.765E-01	0.	1.765E-01
5714400	LA	1.225	1.449	1.341	.625	4.044E-02	5.185E-02	9.229E-02	4.984E+07	1.064E-04	4.463E-01	5.721E-01	1.018E+00
5814400	CE	.115	.037	.075	1.072	3.809E-03	1.326E-03	5.135E-03	8.548E+07	1.121E+02	4.203E-02	1.463E-02	5.666E-02
5914400	PR	1.771	.040	.871	1.091	5.847E-02	1.436E-03	5.991E-02	8.620E+07	4.771E-03	6.433E-01	1.585E-02	6.611E-01
5714500	LA	.444	.589	.520	.724	1.467E-02	2.107E-02	3.575E-02	2.582E+07	3.996E-05	1.619E-01	2.325E-01	3.945E-01
5814500	CE	.621	.691	.652	.760	2.051E-02	2.438E-02	4.489E-02	6.060E+07	6.405E-04	2.263E-01	2.690E-01	4.953E-01
5914500	PR	.729	.013	.357	.727	2.405E-02	4.705E-04	2.453E-02	6.357E+07	7.305E-02	2.655E-01	5.192E-03	2.707E-01
5814600	CE	.198	.234	.218	.629	6.532E-03	8.459E-03	1.499E-02	5.011E+07	2.279E-03	7.208E-02	9.335E-02	1.654E-01
5914600	PR	.779	1.266	1.032	.647	2.571E-02	4.531E-02	7.102E-02	5.159E+07	3.999E-03	2.838E-01	5.000E-01	7.837E-01
5814700	CE	.397	.547	.475	.340	1.312E-02	1.959E-02	3.271E-02	2.869E+07	1.072E-04	1.448E-01	2.162E-01	3.610E-01
5914700	PR	.494	.499	.427	.509	1.630E-02	1.787E-02	3.416E-02	4.056E+07	1.559E-03	1.798E-01	1.972E-01	3.770E-01
6014700	NO	.161	.073	.115	.514	5.326E-03	2.616E-03	7.942E-03	4.102E+07	2.079E+00	5.877E-02	2.886E-02	8.764E-02
5914800	PR	1.004	.134	.553	.379	7.316E-02	4.868E-03	3.803E-02	3.021E+07	1.935E-04	3.659E-01	5.372E-02	4.196E-01
6114900	PM	.250	.009	.124	.911	8.249E-03	3.115E-04	8.556E-03	4.076E+07	4.159E-01	9.098E-02	3.438E-03	9.442E-02

TABLE 8-XXX

TMT-? IF OPERATED 26K HRS AT 2772. MW CONT. CINER-10(LASL) 8/79

27=TIME STEP

1.00000E+02=TOTAL TIME SINCE LAST TIME AT POWER(S)
 9.34917E+07=TOTAL ELAPSED TIME(S)
 6.88811E+19=FISSIONS/S AT LAST TS AT POWER (22)
 2.77200E+09=POWER (WATTS) AT LAST TS AT POWER (2.77200E+03 MW)
 7.28678E+03=ACCUMULATED FISSIONS (FISSIONS PER BARN-CM)
 1.44045E+04=TOTAL FP TN SUM PER BARN-CM

2.63663E+70=TOTAL ACTIVITY (DTS/S)
 7.12602E+09=TOTAL CURIES
 2.95474E+01=TOTAL BETA DECAY POWER (MW)
 3.39110E+01=TOTAL GAMMA DECAY POWER (MW)

6.30594E+01=TOTAL DECAY POWER (MW)
2.67754E+00=TOTAL BETA MFV/F
3.03673E+00=TOTAL GAMMA MFV/F
5.71427E+00=TOTAL DECAY MFV/F

ID	SYM	PERCENT OF ALL PD			MEV/FISS				DECAY POWER IN MW				
		BETA	GAMMA	TOTAL	CURIES	BETA	GAMMA	TOTAL	CURIES	DENSITY	BETA	GAMMA	TOTAL
3604700	KR	.708	.371	.529	.371	1.897E-02	1.127F-02	3.023E-02	2.646E+07	6.441E-03	2.093E-01	1.243E-01	3.336E-01
3609800	KR	.189	1.487	.879	.533	5.073E-03	4.514E-02	5.021E-02	3.799E+07	2.044E-02	5.599E-02	4.981E-01	5.541E-01
3704800	RB	1.527	.464	1.009	.546	4.357E-02	1.410E-02	5.766E-02	3.894E+07	2.208E-03	4.808E-01	1.556E-01	6.363E-01
3608900	KR	.806	1.181	1.075	.454	2.157E-02	3.595E-02	5.742E-02	3.235E+07	3.274E-04	2.380E-01	3.956E-01	6.337E-01
3704900	RB	.922	2.003	1.477	.694	7.469E-02	6.092E-02	8.551E-02	4.947E+07	2.408E-03	2.725E-01	6.712E-01	9.437E-01
3804900	SR	.610	0.070	.286	.733	1.633E-02	0.	1.633E-02	5.223E+07	1.253E+01	1.802E-01	0.	1.802E-01
3709000	RB	1.198	1.694	1.452	.505	3.208E-02	5.145E-02	8.353E-02	3.601E+07	3.114E-04	3.540E-01	5.678E-01	9.218E-01
3704010	RB	.252	.779	.505	.160	4.761E-03	2.210E-02	2.886E-02	1.138E+07	1.559E-04	7.461E-02	2.438E-01	3.185E-01
3704100	RB	.549	.991	.784	.289	1.470E-02	3.011E-02	4.489E-02	2.051E+07	6.371E-05	1.622E-01	3.322E-01	4.944E-01
3809100	SR	.876	.824	.849	.940	2.347E-02	2.502E-02	4.849E-02	6.698E+07	1.220E-01	2.590E-01	2.761E-01	5.351E-01
3909100	Y	.847	.003	.339	.977	7.267E-02	9.951E-05	2.277E-02	6.964E+07	1.882E+01	2.502E-01	1.098E-03	2.513E-01
3909110	Y	0.000	.780	.772	.543	0.	1.153E-02	1.153E-02	3.866E+07	6.154E-03	0.	1.272E-01	1.272E-01
3809200	SR	.280	1.719	1.045	1.019	7.499E-03	5.221E-02	5.971E-02	7.260E+07	3.781E-02	8.275E-02	5.761E-01	6.589E-01
3909200	Y	2.160	.323	1.184	1.032	5.784E-02	9.805E-03	6.764E-02	7.354E+07	4.988E-02	6.383E-01	1.082E-01	7.465E-01
3809300	SR	1.696	1.797	1.749	1.022	4.541E-02	5.456E-02	9.997E-02	7.281E+07	1.749E-03	5.011E-01	6.021E-01	1.103E+00
3909300	Y	2.070	1.138	1.043	1.223	5.543E-02	4.192E-03	5.963E-02	8.713E+07	1.708E-01	6.117E-01	4.626E-02	6.580E-01
3809400	SR	.585	.737	.666	.471	1.567E-02	2.239E-02	3.804E-02	3.354E+07	1.354E-04	1.729E-01	2.470E-01	4.200E-01
3909400	Y	3.121	1.580	2.302	1.271	8.356E-02	4.798E-02	1.315E-01	9.058E+07	5.912E-03	9.221E-01	5.295E-01	1.452E+00
3909500	Y	3.183	.788	1.029	1.275	8.523E-02	2.384E-02	1.091E-01	9.089E+07	3.057E-03	9.405E-01	2.631E-01	1.204E+00
4009500	ZR	.240	1.339	.824	1.444	6.426E-03	4.067E-02	4.710E-02	1.029E+08	3.108E+01	7.091E-02	4.488E-01	5.198E-01
4109500	NB	.091	1.416	.775	1.466	2.445E-03	4.299E-02	4.543E-02	1.045E+08	1.691E+01	2.698E-02	4.744E-01	5.013E-01
3909600	Y	2.762	1.477	2.779	.822	7.395E-02	4.485E-02	1.188E-01	5.716E+07	4.211E-04	8.160E-01	4.949E-01	1.311E+00
4009700	ZR	1.493	.338	.890	1.477	3.999E-02	1.028E-02	5.026E-02	1.053E+08	3.399E-01	4.413E-01	1.134E-01	5.547E-01
4109700	NB	1.001	1.277	1.148	1.497	2.681E-02	3.879E-02	6.559E-02	1.067E+08	2.514E-02	2.958E-01	4.280E-01	7.238E-01
4109710	NB	0.000	1.194	.634	1.275	0.	3.625E-02	3.625E-02	9.087E+07	2.619E-04	0.	4.001E-01	4.001E-01
4209900	MO	.891	.380	.619	1.620	2.385E-02	1.154E-02	3.539E-02	1.154E+08	1.464E+00	2.632E-01	1.273E-01	3.905E-01
4309910	TC	0.000	.252	.134	1.398	0.	7.639E-03	7.639E-03	9.963E+07	1.153E-01	0.	8.430E-02	8.430E-02
4210100	MO	1.197	2.458	1.857	1.407	3.204E-02	7.465E-02	1.067E-01	1.003E+08	4.688E-03	3.536E-01	8.238E-01	1.177E+00
4310100	TC	1.033	.638	.823	1.505	2.766E-02	1.938E-02	4.703E-02	1.073E+08	4.879E-03	3.052E-01	2.138E-01	5.190E-01
4210200	MO	.592	0.000	.278	1.332	1.586E-02	0.	1.586E-02	9.491E+07	3.374E-03	1.750E-01	0.	1.750E-01
4310200	TC	2.895	.785	1.773	1.342	7.751E-02	2.383E-02	1.013E-01	9.564E+07	2.706E-05	8.554E-01	2.629E-01	1.118E+00
4210300	MO	1.054	.703	.888	.555	2.823E-02	2.134E-02	4.958E-02	4.023E+07	1.289E-04	3.116E-01	2.355E-01	5.471E-01
4310300	TC	1.082	.674	.845	1.053	2.897E-02	2.048E-02	4.945E-02	7.502E+07	2.002E-04	3.197E-01	2.260E-01	5.457E-01
4410300	RU	.148	.947	.573	1.534	3.965E-03	2.877E-02	3.274E-02	1.093E+08	1.996E+01	4.375E-02	3.175E-01	3.613E-01
4510310	RH	0.000	.077	.041	1.534	0.	2.336E-03	2.336E-03	1.093E+08	1.960E-02	0.	2.577E-02	2.577E-02
4210400	MO	.437	.343	.387	.588	1.170E-02	1.041E-02	2.211E-02	3.975E+07	2.037E-04	1.149E-01	1.149E-01	2.439E-01
4310400	TC	2.070	2.216	2.148	1.214	5.544E-02	6.729E-02	1.227E-01	8.651E+07	4.987E-03	6.117E-01	7.426E-01	1.354E+00
4210500	MO	.561	.402	.476	.228	1.501E-02	1.220E-02	2.721E-02	1.626E+07	4.686E-05	1.657E-01	1.346E-01	3.002E-01
4310500	TC	1.464	.989	1.211	.977	3.919E-02	3.003E-02	6.922E-02	6.924E+07	1.774E-03	4.325E-01	3.314E-01	7.638E-01
4410500	RU	.634	1.067	.844	1.074	1.697E-02	3.240E-02	4.937E-02	7.657E+07	6.533E-02	1.873E-01	3.575E-01	5.448E-01
4510500	RH	.220	.100	.154	1.010	4.888E-03	3.046E-03	8.933E-03	7.198E+07	4.910E-01	6.497E-02	3.361E-02	9.858E-02
4410600	RU	.009	0.000	.034	.587	2.279E-04	0.	2.279E-04	4.256E+07	7.243E+01	2.515E-03	0.	2.515E-03
4510600	RH	1.244	.151	.643	.402	3.331E-02	4.595E-03	3.790E-02	4.289E+07	6.846E-05	3.676E-01	5.071E-02	4.183E-01
4410700	RU	.809	.145	.456	.447	2.166E-02	4.401E-03	2.606E-02	3.259E+07	4.384E-04	2.391E-01	4.856E-02	2.876E-01
4510700	RH	.342	.274	.279	.559	0.166E-03	6.794E-03	1.596E-02	4.051E+07	2.816E-03	1.012E-01	7.498E-02	1.761E-01
4510800	RH	.817	.279	.511	.313	2.188E-02	8.479E-03	3.036E-02	2.228E+07	2.022E-05	2.414E-01	9.357E-02	3.350E-01
5112900	SB	.158	.905	.383	.338	4.237E-03	1.535E-02	1.959E-02	2.196E+07	1.832E-02	4.675E-02	1.694E-01	2.161E-01
5113010	SB	.606	1.484	1.073	.389	1.622E-07	4.511E-02	6.134E-02	2.763E+07	3.274E-03	1.790E-01	4.978E-01	6.769E-01
5113100	SB	.710	1.493	1.126	.696	1.901E-02	4.534E-02	6.435E-02	4.958E+07	3.652E-03	2.097E-01	5.003E-01	7.101E-01
5213100	TE	.747	.414	.570	.777	1.999E-02	1.258E-02	3.257E-02	5.540E+07	4.436E-03	2.206E-01	1.388E-01	3.594E-01
5313100	I	.238	.440	.345	.897	6.369E-03	1.337E-02	1.973E-02	6.392E+07	2.370E+00	7.028E-02	1.475E-01	2.178E-01

5113200	SA	.675	.694	.695	.274	1.809E-02	2.107E-02	3.916E-02	1.955E+07	1.315E-04	1.996E-01	2.326E-01	4.322E-01
5113210	SM	.499	.529	.514	.204	1.335E-02	1.605E-02	2.940E-02	1.466E+07	1.925E-04	1.473E-01	1.771E-01	3.244E-01
5213200	TE	.109	.430	.280	1.271	2.921E-03	1.307E-02	1.599E-02	9.057E+07	1.358E+00	3.224E-02	1.442E-01	1.764E-01
5313200	I	.971	3.653	2.326	1.295	2.601E-02	1.109E-01	1.369E-01	9.228E+07	4.052E-02	2.870E-01	1.224E+00	1.511E+00
5113300	SA	.222	.913	.599	.290	5.955E-03	2.772E-02	3.367E-02	2.064E+07	1.586E-04	6.571E-02	3.059E-01	3.716E-01
5213300	TE	1.130	1.195	1.155	.954	3.027E-02	3.629E-02	6.656E-02	6.872E+07	2.751E-03	3.340E-01	4.005E-01	7.345E-01
5213310	TE	.477	1.421	.979	.604	1.277E-02	4.316E-02	5.593E-02	4.306E+07	7.640E-03	1.409E-01	4.763E-01	6.172E-01
5313300	I	1.064	1.344	1.214	1.793	2.848E-02	4.089E-02	6.936E-02	1.271E+08	5.080E-01	3.143E-01	4.512E-01	7.655E-01
5413300	XE	.263	.195	.222	1.404	7.035E-03	5.624E-03	1.266E-02	1.286E+08	3.137E+00	7.764E-02	6.206E-02	1.397E-01
5213400	TE	.275	1.313	.927	1.243	7.351E-03	3.988E-02	4.723E-02	8.999E+07	1.210E-02	8.112E-02	4.401E-01	5.212E-01
5313400	I	1.877	6.209	4.179	1.927	5.025E-02	1.886E-01	2.388E-01	1.354E+08	2.281E-02	5.545E-01	2.081E+00	2.635E+00
5313500	I	.928	3.028	2.044	1.650	2.486E-02	9.194E-02	1.168E-01	1.176E+08	1.488E-01	2.743E-01	1.015E+00	1.289E+00
5313600	I	.968	1.044	1.009	.774	2.593E-02	3.169E-02	5.763E-02	2.666E+07	1.181E-04	2.862E-01	3.498E-01	6.359E-01
5413700	XF	3.148	.294	1.632	1.196	8.429E-02	8.942E-03	9.323E-02	8.525E+07	1.048E-03	9.302E-01	9.867E-02	1.029E+00
5413800	XE	1.223	1.959	1.614	1.320	3.274E-02	5.949E-02	9.222E-02	9.267E+07	4.214E-03	3.613E-01	6.564E-01	1.018E+00
5513800	CS	2.696	4.395	3.523	1.424	7.217E-02	1.332E-01	2.053E-01	1.064E+08	1.098E-02	7.965E-01	1.469E+00	2.266E+00
5513900	CS	3.449	.536	1.921	1.349	9.234E-02	1.627E-02	1.086E-01	9.747E+07	2.903E-03	1.019E+00	1.796E-01	1.199E+00
5613900	BA	1.983	.102	.993	1.546	5.309E-02	3.094E-03	5.618E-02	1.101E+08	2.939E-02	5.859E-01	3.414E-02	6.200E-01
5514000	CS	1.413	1.325	1.323	.512	3.783E-02	4.175E-02	7.958E-02	3.647E+07	1.242E-04	4.175E-01	4.607E-01	8.781E-01
5614000	BA	.601	.410	.429	1.429	1.609E-02	1.245E-02	2.853E-02	1.069E+08	6.303E+00	1.775E-01	1.374E-01	3.149E-01
5714000	LA	1.162	4.559	2.798	1.573	3.112E-02	1.385E-01	1.696E-01	1.121E+08	8.664E-01	3.435E-01	1.528E+00	1.871E+00
5614100	BA	1.776	1.519	1.640	1.357	4.756E-02	4.613E-02	9.349E-02	9.671E+07	5.669E-03	5.249E-01	5.090E-01	1.034E+00
5714100	LA	2.026	.059	.991	1.432	5.424E-02	1.798E-03	5.604E-02	1.020E+08	7.587E-02	5.986E-01	1.984E-02	6.184E-01
5814100	CE	.327	.130	.222	1.435	8.759E-03	3.938E-03	1.270E-02	1.022E+08	1.534E+01	9.666E-02	4.345E-02	1.401E-01
5614200	BA	.738	1.538	1.143	1.205	1.975E-02	4.671E-02	6.646E-02	8.586E+07	2.943E-03	2.180E-01	5.154E-01	7.334E-01
5714200	LA	1.463	4.163	3.096	1.376	4.989E-02	1.264E-01	1.763E-01	9.807E+07	2.902E-02	5.505E-01	1.395E+00	1.946E+00
5714300	LA	1.438	1.732	1.528	1.210	3.849E-02	5.282E-02	9.131E-02	8.620E+07	3.865E-03	4.247E-01	5.829E-01	1.008E+00
5814300	CE	.778	.444	.622	1.229	2.083E-02	1.470E-02	3.554E-02	9.253E+07	5.868E-01	2.299E-01	1.623E-01	3.922E-01
5914300	PR	.597	0.000	.290	1.290	1.600E-02	0.	1.600E-02	9.193E+07	5.758E+00	1.765E-01	0.	1.765E-01
5714400	LA	.553	.625	.591	.256	1.480E-02	1.897E-02	3.377E-02	1.824E+07	3.894E-05	1.633E-01	2.094E-01	3.727E-01
5814400	CE	.142	.044	.020	1.129	3.809E-03	1.326E-03	5.135E-03	8.548E+07	1.121E+02	4.203E-02	1.463E-02	5.666E-02
5914400	PR	2.183	.047	1.048	1.229	5.845E-02	1.435E-03	5.989E-02	8.618E+07	4.769E-03	6.450E-01	1.584E-02	6.609E-01
5814500	CE	.653	.694	.670	.725	1.748E-02	2.078E-02	3.827E-02	5.166E+07	5.461E-04	1.929E-01	2.294E-01	4.223E-01
5914500	PR	.898	.015	.429	.822	2.406E-02	4.704E-04	2.453E-02	6.355E+07	7.303E-02	2.655E-01	5.191E-03	2.706E-01
5814600	CE	.232	.265	.250	.629	6.223E-03	8.059E-03	1.428E-02	4.773E+07	2.171E-03	6.867E-02	8.893E-02	1.576E-01
5914600	PR	.959	1.490	1.241	.723	2.568E-02	4.524E-02	7.092E-02	5.151E+07	3.993E-03	2.833E-01	4.992E-01	7.826E-01
5914700	PR	.593	.522	.592	.554	1.587E-02	1.740E-02	3.327E-02	3.950E+07	1.518E-03	1.751E-01	1.920E-01	3.672E-01
6014700	ND	.199	.044	.139	.525	5.326E-03	2.616E-03	7.942E-03	4.102E+07	2.079E+00	5.877E-02	2.886E-02	8.764E-02
5914800	PR	.991	.129	.533	.339	2.654E-02	3.896E-03	3.044E-02	2.418E+07	1.549E-04	2.929E-01	4.300E-02	3.359E-01
6114900	PM	.308	.010	.150	.572	8.244E-03	3.115E-04	8.556E-03	4.075E+07	4.159E-01	9.097E-02	3.438E-03	9.441E-02
6215300	SM	.166	.066	.113	.504	4.451E-03	2.016E-03	6.467E-03	3.592E+07	3.223E-01	4.911E-02	2.225E-02	7.137E-02

TABLE B-XXXI

TMT-2 IF OPERATED 26K HRS AT 2772. MW CONT. CINER-10(LASL) 8/79

28=TIME STEP
 4.00000E+02=TOTAL TIME SINCE LAST TIME AT POWER(S)
 9.34920E+07=TOTAL ELAPSED TIME(S)
 6.88811E+19=FISSIONS/S AT LAST TS AT POWER (22)
 2.77200E+09=POWER (WATTS) AT LAST TS AT POWER (2.77200E+03 MW)
 7.28678E+03=ACCUMULATED FISSIONS (FISSIONS PER BARN-CM)
 1.44045E+04=TOTAL FP TN SIMM PER BARN-CM

2.19484E+20=TOTAL ACTIVITY (DTS/S)
 5.93200E+09=TOTAL CURIES
 2.10801E+01=TOTAL BETA DECAY POWER (MW)
 2.59069E+01=TOTAL GAMMA DECAY POWER (MW)
 4.69870E+01=TOTAL DECAY POWER (MW)
 1.91025E+00=TOTAL BETA MEV/F
 2.34765E+00=TOTAL GAMMA MEV/F
 4.25790E+00=TOTAL DECAY MEV/F

ID ZAAAS	SYM	PERCENT OF ALL F				MEV/FISS			CURIES	DENSITY	DECAY POWER IN MW		
		BETA	GAMMA	TOTAL	CURIES	BETA	GAMMA	TOTAL			BETA	GAMMA	TOTAL
3608700	KR	.952	.460	.691	.429	1.818E-02	1.080E-02	2.898E-02	2.536E+07	6.173E-03	2.006E-01	1.192E-01	3.198E-01
3608800	KR	.260	1.894	1.155	.627	4.970E-03	4.422E-02	4.919E-02	3.722E+07	2.003E-02	5.484E-02	4.880E-01	5.428E-01
3708800	RB	2.267	.597	1.346	.647	4.330E-02	1.401E-02	5.731E-02	3.870E+07	2.194E-03	4.778E-01	1.546E-01	6.324E-01
3608900	KR	.377	.510	.450	.182	7.203E-03	1.197E-02	1.918E-02	1.080E+07	1.093E-04	7.949E-02	1.321E-01	2.116E-01
3708900	RB	1.132	2.269	1.799	.730	2.162E-02	5.325E-02	7.496E-02	4.331E+07	2.108E-03	2.386E-01	5.876E-01	8.261E-01
3808900	SR	.855	0.000	.393	.890	1.633E-02	0.	1.633E-02	5.223E+07	1.253E+01	1.807E-01	0.	1.802E-01
3709000	RB	.492	.647	.575	.179	9.396E-03	1.507E-02	2.447E-02	1.055E+07	9.120E-05	1.037E-01	1.663E-01	2.700E-01
3809100	SR	1.222	1.060	1.132	1.123	2.334E-02	2.488E-02	4.822E-02	6.661E+07	1.213E-01	2.575E-01	2.746E-01	5.321E-01
3909100	Y	1.187	.004	.535	1.174	2.267E-02	9.951E-05	2.277E-02	6.964E+07	1.882E+01	2.502E-01	1.098E-03	2.513E-01
3909110	Y	0.000	.491	.271	.651	0.	1.152E-02	1.152E-02	3.864E+07	6.151E-03	0.	1.272E-01	1.272E-01
3809200	SR	.384	2.177	1.373	1.108	7.340E-03	5.111E-02	5.845E-02	7.107E+07	3.701E-02	8.100E-02	5.640E-01	6.450E-01
3909200	Y	3.027	.417	1.599	1.239	5.782E-02	9.801E-03	6.762E-02	7.351E+07	4.987E-02	6.380E-01	1.082E-01	7.462E-01
3809300	SR	1.497	1.464	1.479	.773	2.861E-02	3.437E-02	6.297E-02	4.587E+07	1.102E-03	3.157E-01	3.793E-01	6.949E-01
3909300	Y	2.897	.178	1.398	1.446	4.533E-02	4.184E-03	5.952E-02	8.697E+07	1.705E-01	6.106E-01	4.618E-02	6.568E-01
3909400	Y	3.733	1.744	2.637	1.333	7.132E-02	4.095E-02	1.123E-01	7.731E+07	4.704E-03	7.870E-01	4.519E-01	1.239E+00
3909500	Y	3.215	.737	1.945	1.104	6.142E-02	1.718E-02	7.860E-02	6.550E+07	2.203E-03	6.778E-01	1.896E-01	8.673E-01
4009500	ZR	.336	1.733	1.106	1.734	6.426E-03	4.067E-02	4.710E-02	1.029E+08	3.107E-01	7.091E-02	4.488E-01	5.197E-01
4109500	NB	.128	1.831	1.067	1.741	7.445E-03	4.299E-02	4.543E-02	1.045E+08	1.691E+01	2.698E-02	4.744E-01	5.013E-01
3909600	Y	.858	.423	.619	.214	1.639E-02	9.938E-03	2.633E-02	1.267E+07	9.332E-05	1.808E-01	1.097E-01	2.905E-01
4009700	ZR	2.086	.436	1.176	1.769	3.985E-02	1.024E-02	5.009E-02	1.049E+08	3.387E-01	4.397E-01	1.130E-01	5.528E-01
4109700	NB	1.402	1.651	1.540	1.797	2.679E-02	3.876E-02	6.555E-02	1.066E+08	2.912E-02	2.956E-01	4.277E-01	7.234E-01
4109710	NB	0.000	1.539	.869	1.526	0.	3.611E-02	3.611E-02	9.052E+07	2.609E-04	0.	3.985E-01	3.985E-01
4209900	MD	1.248	.491	.830	1.944	2.383E-02	1.153E-02	3.536E-02	1.153E+08	1.463E+00	2.630E-01	1.272E-01	3.902E-01
4309910	TC	0.000	.375	.179	1.680	0.	7.639E-03	7.639E-03	9.963E+07	1.153E-01	0.	8.430E-02	8.430E-02
4210100	MD	1.323	2.509	1.976	1.333	2.527E-02	5.888E-02	8.415E-02	7.907E+07	3.698E-03	2.789E-01	6.497E-01	9.286E-01
4310100	TC	1.394	.795	1.063	1.741	2.663E-02	1.865E-02	4.528E-02	1.033E+08	4.697E-03	2.938E-01	2.058E-01	4.997E-01
4210200	MD	.609	0.000	.273	1.173	1.162E-02	0.	1.162E-02	6.956E+07	2.473E-03	1.283E-01	0.	1.283E-01
4310200	TC	2.975	.744	1.745	1.182	5.683E-02	1.747E-02	7.430E-02	7.012E+07	1.984E-05	6.271E-01	1.928E-01	8.199E-01
4410300	RU	.208	1.225	.769	1.843	3.965E-03	2.877E-02	3.274E-02	1.093E+08	1.996E+01	4.379E-02	3.175E-01	3.612E-01
4510310	RH	0.000	.099	.059	1.843	0.	2.336E-03	2.336E-03	1.093E+08	1.960E-02	0.	2.577E-02	2.577E-02
4310400	TC	2.486	2.456	2.459	1.249	4.749E-02	5.765E-02	1.051E-01	7.411E+07	4.273E-03	5.241E-01	6.362E-01	1.160E+00
4310500	TC	1.369	.853	1.084	.779	2.614E-02	2.003E-02	4.617E-02	4.619E+07	1.184E-03	2.885E-01	2.211E-01	5.095E-01
4410500	RU	.886	1.375	1.156	1.287	1.692E-02	3.229E-02	4.921E-02	7.632E+07	6.512E-02	1.867E-01	3.563E-01	5.430E-01
4510500	RH	.308	.130	.210	1.214	5.888E-03	3.046E-03	8.934E-03	7.199E+07	4.911E-01	6.498E-02	3.361E-02	9.859E-02
4410600	RU	.012	0.000	.075	.717	2.279E-04	0.	2.279E-04	4.256E+07	7.243E+01	2.515E-03	0.	2.515E-03
4510600	RH	1.730	.194	.893	.717	3.305E-02	4.559E-03	3.761E-02	4.256E+07	6.793E-05	3.647E-01	5.031E-02	4.150E-01
4410700	RU	.501	.093	.270	.243	9.569E-03	1.944E-03	1.151E-02	1.440E+07	1.936E-04	1.056E-01	2.145E-02	1.270E-01
4510700	RH	.448	.270	.350	.437	8.551E-03	6.338E-03	1.489E-02	3.779E+07	2.627E-03	9.436E-02	6.994E-02	1.643E-01
4510800	RH	.531	.147	.331	.174	1.014E-02	3.931E-03	1.407E-02	1.033E+07	9.373E-06	1.119E-01	4.338E-02	1.553E-01
5112900	S9	.220	.644	.456	.367	4.200E-03	1.522E-02	1.942E-02	2.177E+07	1.816E-02	4.635E-02	1.679E-01	2.143E-01
5113010	S8	.799	1.908	1.356	.638	1.527E-02	4.246E-02	5.772E-02	2.600E+07	3.081E-03	1.685E-01	4.685E-01	6.370E-01
5113100	S8	.861	1.671	1.377	.723	1.644E-02	3.927E-02	5.566E-02	4.289E+07	3.159E-03	1.814E-01	4.328E-01	6.143E-01
5213100	TE	1.020	.923	.746	.911	1.949E-02	1.227E-02	3.176E-02	5.402E+07	4.326E-03	2.151E-01	1.354E-01	3.505E-01
5313100	I	.333	.567	.443	1.077	6.369E-03	1.336E-02	1.973E-02	6.392E+07	2.370E+00	7.029E-02	1.475E-01	2.178E-01
5213200	TE	.153	.556	.375	1.526	2.920E-03	1.306E-02	1.598E-02	9.052E+07	1.357E+00	3.222E-02	1.441E-01	1.763E-01
5313200	I	1.361	4.723	3.214	1.555	2.600E-02	1.109E-01	1.369E-01	9.224E+07	4.050E-02	2.869E-01	1.223E+00	1.510E+00
5213300	TE	1.289	1.297	1.271	.942	2.462E-02	2.952E-02	5.414E-02	5.589E+07	2.238E-03	2.717E-01	3.258E-01	5.974E-01
5213310	TE	.628	1.729	1.234	.692	1.200E-02	4.056E-02	5.256E-02	4.046E+07	7.179E-03	1.324E-01	4.476E-01	5.800E-01

5313300	I	1.490	1.747	1.428	2.141	2.846E-02	4.086E-02	6.932E-02	1.270E+08	5.077E-01	3.141E-01	4.509E-01	7.650E-01
5413300	XE	.368	.247	.297	2.167	7.035E-03	5.624E-03	1.266E-02	1.286E+08	3.137E+00	7.764E-02	6.206E-02	1.397E-01
5213400	YF	.354	1.464	1.021	1.397	6.769E-03	3.672E-02	4.349E-02	8.286E+07	1.115E-02	7.470E-02	4.052E-01	4.799E-01
5313400	I	2.578	7.972	5.427	2.237	4.925E-02	1.848E-01	2.341E-01	1.327E+08	2.236E-02	5.435E-01	2.039E+00	2.583E+00
5513400	CS	.064	.510	.310	.239	1.222E-03	1.197E-02	1.319E-02	1.410E+07	4.894E+01	1.348E-02	1.321E-01	1.455E-01
5313500	I	1.290	3.882	2.719	1.944	2.464E-02	9.114E-02	1.158E-01	1.165E+08	1.475E-01	2.719E-01	1.006E+00	1.278E+00
5413700	XE	1.797	.155	.822	.585	3.433E-02	3.642E-03	3.797E-02	3.472E+07	4.270E-04	3.788E-01	4.019E-02	4.190E-01
5613800	XE	1.343	1.985	1.627	1.224	2.565E-02	4.660E-02	7.225E-02	7.260E+07	3.302E-03	2.830E-01	5.143E-01	7.973E-01
5513800	CS	3.692	5.532	4.710	1.752	7.049E-02	1.300E-01	2.005E-01	1.039E+08	1.072E-02	7.778E-01	1.435E+00	2.213E+00
5513900	CS	3.367	.489	1.777	1.144	6.431E-02	1.133E-02	7.564E-02	6.788E+07	2.022E-03	7.097E-01	1.250E-01	8.347E-01
5613900	BA	2.750	.130	1.306	1.817	5.253E-02	3.042E-03	5.560E-02	1.090E+08	2.908E-02	5.797E-01	3.378E-02	6.135E-01
5614000	BA	.942	.530	.670	1.801	1.608E-02	1.245E-02	2.853E-02	1.068E+08	6.302E+00	1.775E-01	1.373E-01	3.148E-01
5714000	LA	1.629	5.897	3.992	1.899	3.112E-02	1.384E-01	1.696E-01	1.121E+08	8.664E-01	3.434E-01	1.528E+00	1.871E+00
5614100	BA	2.062	1.629	1.829	1.391	3.940E-02	3.821E-02	7.761E-02	8.011E+07	4.696E-03	4.348E-01	4.217E-01	8.564E-01
5714100	LA	2.834	.076	1.313	1.716	5.413E-02	1.794E-03	5.593E-02	1.018E+08	7.571E-02	5.974E-01	1.980E-02	6.172E-01
5814100	CE	.459	.169	.298	1.724	8.759E-03	3.938E-03	1.270E-02	1.022E+08	1.534E+01	9.666E-02	4.345E-02	1.401E-01
5614200	BA	.748	1.432	1.129	1.047	1.429E-02	3.378E-02	4.807E-02	6.211E+07	2.128E-03	1.577E-01	3.728E-01	5.305E-01
5714200	LA	2.587	5.335	4.102	1.538	4.942E-02	1.253E-01	1.747E-01	9.716E+07	2.875E-02	5.454E-01	1.382E+00	1.928E+00
5714300	LA	1.573	1.757	1.674	1.135	3.005E-02	4.124E-02	7.129E-02	6.730E+07	3.018E-03	3.316E-01	4.551E-01	7.867E-01
5814300	CE	1.090	.624	.834	1.559	2.083E-02	1.470E-02	3.553E-02	9.251E+07	5.866E-01	2.298E-01	1.622E-01	3.920E-01
5914300	PR	.837	0.000	.375	1.550	1.600E-02	0.	1.600E-02	9.193E+07	5.758E+00	1.765E-01	0.	1.765E-01
5814400	CE	.199	.056	.121	1.441	3.809E-03	1.326E-03	5.134E-03	8.547E+07	1.121E+02	4.203E-02	1.463E-02	5.666E-02
5914400	PR	3.055	.061	1.404	1.451	5.837E-02	1.433E-03	5.980E-02	8.605E+07	4.762E-03	6.441E-01	1.582E-02	6.599E-01
5914500	PR	1.253	.020	.573	1.066	2.394E-02	4.682E-04	2.441E-02	6.325E+07	7.269E-02	2.642E-01	5.167E-03	2.694E-01
5814600	CE	.255	.269	.243	.630	4.875E-03	6.313E-03	1.119E-02	3.740E+07	1.701E-03	5.380E-02	6.967E-02	1.235E-01
5914600	PR	1.312	1.881	1.625	.848	2.506E-02	4.415E-02	6.921E-02	5.028E+07	3.897E-03	2.765E-01	4.872E-01	7.638E-01
5914700	PR	.648	.578	.629	.519	1.237E-02	1.356E-02	2.594E-02	3.079E+07	1.183E-03	1.365E-01	1.497E-01	2.862E-01
6014700	ND	.279	.111	.187	.692	5.326E-03	2.616E-03	7.941E-03	4.102E+07	2.079E+00	5.877E-02	2.886E-02	8.763E-02
6114900	PM	.431	.013	.221	.657	8.240E-03	3.114E-04	8.552E-03	4.074E+07	4.157E-01	9.093E-02	3.436E-03	9.437E-02
6215300	SM	.233	.086	.152	.825	4.446E-03	2.014E-03	6.460E-03	3.588E+07	3.220E-01	4.906E-02	2.223E-02	7.129E-02
6315600	EU	.235	.587	.429	.328	4.496E-03	1.377E-02	1.827E-02	1.946E+07	1.364E+00	4.962E-02	1.520E-01	2.016E-01

TABLE B-XXXII

TMT, UNIT 2, 22-STEP POWER HISTORY, FULL CORE CALC., CINDER-10(LASL) 7/79

29=TIME STEP

1.00000E+03=TOTAL TIME SINCE LAST TIME AT POWER(S)
9.34926E+07=TOTAL ELAPSED TIME(S)
6.88811E+19=FISSIONS/S AT LAST TS AT POWER (22)
2.77200E+09=POWER (WATTS) AT LAST TS AT POWER (2.77200E+03 MW)
7.28678E+03=ACCUMULATED FISSIONS (FISSIONS PER BARN-XXXIIC)
1.44045E+04=TOTAL FP IN SIM PER BARN-CM

1.91487E+20=TOTAL ACTIVITY (DTS/S)
5.17533E+09=TOTAL CURIES
1.65560E+01=TOTAL BETA DECAY POWER (MW)
2.16342E+01=TOTAL GAMMA DECAY POWER (MW)
3.81901E+01=TOTAL DECAY POWER (MW)
1.50029E+00=TOTAL BETA MFV/F
1.96046E+00=TOTAL GAMMA MFV/F
3.46074E+00=TOTAL DECAY MFV/F

ID	SYM	-----PERCENT OF ALL FP-----				-----MEV/FISS-----				---DECAY POWER IN MW---			
		ZZAAAS	BETA	GAMMA	TOTAL	CURIES	BETA	GAMMA	TOTAL	CURIES	DENSITY	BETA	GAMMA
3608700	KR	1.106	.503	.754	.447	1.660E-02	9.857E-03	2.645E-02	2.315E+07	5.635E-03	1.831E-01	1.088E-01	2.919E-01
3608800	KR	.318	2.164	1.354	.690	4.769E-03	4.243E-02	4.720E-02	3.572E+07	1.922E-02	5.263E-02	4.683E-01	5.209E-01
370H400	RB	2.831	.701	1.674	.734	4.247E-02	1.374E-02	5.621E-02	3.796E+07	2.152E-03	4.686E-01	1.516E-01	6.203E-01
370H900	RB	.963	1.814	1.445	.559	1.444E-02	3.557E-02	5.001E-02	2.893E+07	1.408E-03	1.594E-01	3.925E-01	5.519E-01
3804900	SR	1.098	0.000	.472	1.079	1.633E-02	0.	1.633E-02	5.223E+07	1.293E+01	1.802E-01	0.	1.802E-01
3809100	SR	1.537	1.294	1.774	1.271	2.306E-02	2.458E-02	4.763E-02	6.580E+07	1.199E-01	2.544E-01	2.712E-01	5.257E-01
3909100	Y	1.511	.009	.659	1.344	2.267E-02	9.951E-05	2.277E-02	6.964E+07	1.882E+01	2.502E-01	1.098E-03	2.513E-01
3909110	Y	0.000	.587	.332	.745	0.	1.150E-02	1.150E-02	3.857E+07	6.139E-03	0.	1.269E-01	1.269E-01
3809200	SR	.469	2.499	1.619	1.316	7.034E-03	4.899E-02	5.601E-02	6.810E+07	3.547E-02	7.762E-02	5.405E-01	6.181E-01
3909200	Y	3.847	.499	1.950	1.419	5.772E-02	9.794E-03	6.750E-02	7.338E+07	4.978E-02	6.369E-01	1.080E-01	7.449E-01
3809300	SR	.757	.696	.722	.352	1.135E-02	1.364E-02	2.499E-02	1.820E+07	4.372E-04	1.253E-01	1.505E-01	2.758E-01
3909300	Y	3.661	.212	1.707	1.669	5.493E-02	4.154E-03	5.909E-02	8.633E+07	1.692E-01	6.062E-01	4.584E-02	6.520E-01
3909400	Y	3.307	1.453	2.257	1.039	4.961E-02	2.849E-02	7.810E-02	5.378E+07	3.273E-03	5.475E-01	3.144E-01	8.619E-01
3909500	Y	2.116	.493	1.174	.654	1.174E-02	8.878E-03	4.062E-02	3.385E+07	1.138E-03	3.503E-01	9.797E-02	4.482E-01
4009500	ZR	.428	2.075	1.351	1.999	6.425E-03	4.067E-02	4.710E-02	1.029E+08	3.107E+01	7.091E-02	4.488E-01	5.197E-01
4107500	NR	.163	2.193	1.313	2.019	2.445E-03	4.299E-02	4.543E-02	1.045E+08	1.691E+01	2.698E-02	4.744E-01	5.013E-01
4007700	ZR	2.638	.519	1.437	2.013	3.958E-02	1.017E-02	4.975E-02	1.042E+08	3.364E-01	4.367E-01	1.123E-01	5.490E-01
4107900	NR	1.783	1.974	1.891	2.056	2.675E-02	3.870E-02	6.544E-02	1.064E+08	2.508E-02	2.952E-01	4.270E-01	7.222E-01
4107710	NR	0.000	1.829	1.035	1.737	0.	3.586E-02	3.586E-02	8.989E+07	2.591E-04	0.	3.958E-01	3.958E-01
4209900	MD	1.586	.587	1.020	2.224	2.379E-02	1.151E-02	3.530E-02	1.151E+08	1.461E+00	2.625E-01	1.270E-01	3.895E-01
4309910	TC	0.000	.390	.221	1.925	0.	7.639E-03	7.639E-03	9.962E+07	1.153E-01	0.	8.429E-02	8.429E-02
4210100	MD	1.048	1.869	1.513	.950	1.572E-02	3.662E-02	5.234E-02	4.919E+07	2.300E-03	1.735E-01	4.042E-01	5.776E-01
4310100	TC	1.499	.804	1.175	1.695	2.249E-02	1.576E-02	3.825E-02	8.724E+07	3.967E-03	2.482E-01	1.739E-01	4.221E-01
4210200	MD	.415	0.070	.190	.720	6.226E-03	0.	6.226E-03	3.725E+07	1.324E-03	6.870E-02	0.	6.870E-02
4310200	TC	2.029	.477	1.150	.726	3.043E-02	9.355E-03	3.979E-02	3.755E+07	1.062E-05	3.359E-01	1.032E-01	4.391E-01
4410300	RU	.264	1.467	.964	2.112	3.964E-03	2.877E-02	2.773E-02	1.093E+08	1.996E+01	4.375E-02	3.174E-01	3.612E-01
4510310	RH	0.000	.119	.057	2.112	0.	2.336E-03	2.336E-03	1.093E+08	1.960E-02	0.	2.577E-02	2.577E-02
4310400	TC	2.166	2.013	2.079	.990	3.250E-02	3.946E-02	7.196E-02	5.072E+07	2.924E-03	3.987E-01	4.354E-01	7.941E-01
4310500	TC	.733	.430	.552	.375	1.100E-02	8.430E-03	1.943E-02	1.944E+07	4.981E-04	1.214E-01	9.303E-02	2.144E-01
4410500	RU	1.110	1.622	1.490	1.457	1.666E-02	3.180E-02	4.845E-02	7.515E+07	6.412E-02	1.838E-01	3.509E-01	5.347E-01
4510500	RH	.393	.155	.258	1.391	5.889E-03	3.046E-03	8.936E-03	7.200E+07	4.912E-01	6.499E-02	3.362E-02	9.861E-02
4410600	RU	.015	0.000	.077	.822	2.279E-04	0.	2.279E-04	4.256E+07	7.243E+01	2.515E-03	0.	2.515E-03
4510600	RH	2.203	.233	1.097	.822	3.305E-02	4.559E-03	3.761E-02	4.256E+07	6.792E-05	3.647E-01	5.031E-02	4.150E-01
4510700	RH	.442	.291	.334	.566	6.631E-03	4.915E-03	1.155E-02	2.931E+07	2.037E-03	7.317E-02	5.424E-02	1.274E-01
5112810	SB	.333	.535	.447	.190	5.001E-03	1.049E-02	1.549E-02	9.829E+06	3.274E-04	5.519E-02	1.157E-01	1.709E-01
5112900	SB	.274	.759	.569	.411	4.104E-03	1.487E-02	1.897E-02	2.128E+07	1.774E-02	4.529E-02	1.641E-01	2.094E-01
5113010	SB	.961	1.891	1.411	.425	1.291E-02	3.591E-02	4.892E-02	2.199E+07	2.606E-03	1.425E-01	3.962E-01	5.387E-01
5113100	SB	.811	1.480	1.170	.613	1.217E-02	2.902E-02	4.114E-02	3.174E+07	2.338E-03	1.343E-01	3.203E-01	4.545E-01
5213100	TE	1.195	.575	.844	.060	1.792E-02	1.128E-02	2.920E-02	4.967E+07	3.977E-03	1.978E-01	1.245E-01	3.222E-01
5313100	I	.424	.582	.370	1.735	6.368E-03	1.336E-02	1.973E-02	6.391E+07	2.370E+00	7.028E-02	1.475E-01	2.178E-01
5213200	TE	.194	.669	.451	1.747	2.916E-03	1.304E-02	1.596E-02	9.039E+07	1.355E+00	3.217E-02	1.439E-01	1.761E-01
5313200	I	1.731	5.590	3.951	1.791	2.597E-02	1.108E-01	1.367E-01	9.215E+07	4.046E-02	2.866E-01	1.222E+00	1.509E+00
5213300	TE	1.021	.937	.973	.672	1.532E-02	1.837E-02	3.369E-02	3.478E+07	1.392E-03	1.691E-01	2.027E-01	3.718E-01
5213310	TF	.706	1.826	1.340	.670	1.059E-02	3.579E-02	4.638E-02	3.571E+07	6.335E-03	1.168E-01	3.950E-01	5.118E-01
5313300	I	1.893	2.087	1.929	2.449	2.840E-02	4.077E-02	6.917E-02	1.267E+08	5.066E-01	3.134E-01	4.499E-01	7.633E-01
5413300	XE	.469	.287	.364	2.494	7.035E-03	5.624E-03	1.266E-02	1.286E+08	3.137E+00	7.764E-02	6.206E-02	1.397E-01
5213400	TE	.383	1.598	1.055	1.357	5.739E-03	3.113E-02	3.697E-02	7.025E+07	9.450E-03	6.333E-02	3.436E-01	4.069E-01
5313400	I	3.115	8.945	6.418	2.433	4.674E-02	1.754E-01	2.221E-01	1.259E+08	2.121E-02	5.157E-01	1.935E+00	2.451E+00
5513400	CS	.081	.410	.391	.272	1.222E-03	1.197E-02	1.319E-02	1.410E+07	4.894E+01	1.348E-02	1.321E-01	1.455E-01
5313500	I	1.614	4.568	3.297	2.213	2.421E-02	8.956E-02	1.138E-01	1.145E+08	1.449E-01	2.672E-01	9.883E-01	1.259E+00
5413900	XE	1.049	1.499	1.291	.851	1.574E-02	2.860E-02	4.435E-02	4.456E+07	2.027E-03	1.737E-01	3.157E-01	4.894E-01
5513900	CS	4.287	6.053	5.297	1.833	6.431E-02	1.187E-01	1.830E-01	9.484E+07	9.781E-03	7.097E-01	1.309E+00	2.019E+00
5513900	CS	2.035	.274	1.037	.423	3.052E-02	5.378E-03	3.590E-02	3.222E+07	9.597E-04	3.368E-01	5.935E-02	3.962E-01
5613900	BA	3.344	.149	1.334	2.011	9.017E-02	2.924E-03	5.310E-02	1.041E+08	2.777E-02	5.537E-01	3.227E-02	5.899E-01
5614000	BA	1.072	.635	.824	2.063	1.609E-02	1.244E-02	2.852E-02	1.068E+08	6.300E+00	1.774E-01	1.373E-01	3.147E-01
5714000	LA	2.074	2.061	4.899	2.155	3.112E-02	1.384E-01	1.695E-01	1.120E+08	8.662E-01	3.434E-01	1.528E+00	1.871E+00
5614100	BA	1.798	1.334	1.535	1.060	2.698E-02	2.616E-02	5.314E-02	5.485E+07	3.215E-03	2.977E-01	2.887E-01	5.864E-01
5714100	LA	3.572	.091	1.600	1.947	5.358E-02	1.776E-03	5.536E-02	1.008E+08	7.494E-02	5.913E-01	1.960E-02	6.109E-01

5814100	CE	.584	.201	.347	1.975	8.759E-03	3.938E-03	1.270E-02	1.022E+08	1.534E+01	9.666E-02	4.345E-02	1.401E-01
5614200	BA	.498	.902	.777	.624	7.475E-03	1.768E-02	2.515E-02	3.249E+07	1.114E-03	8.249E-02	1.951E-01	2.775E-01
5714200	LA	3.168	6.144	4.894	1.875	4.753E-02	1.204E-01	1.680E-01	9.343E+07	2.765E-02	5.245E-01	1.329E+00	1.854E+00
5714300	LA	1.221	1.242	1.254	.793	1.832E-02	2.514E-02	4.345E-02	4.102E+07	1.839E-03	2.021E-01	2.774E-01	4.795E-01
5814300	CE	1.386	.749	1.025	1.785	7.080E-02	1.468E-02	3.547E-02	9.237E+07	5.857E-01	2.295E-01	1.620E-01	3.915E-01
5914300	PR	1.066	0.000	.462	1.774	1.600E-02	0.	1.600E-02	9.193E+07	5.758E+00	1.765E-01	0.	1.769E-01
5814400	CF	.254	.068	.144	1.652	3.809E-03	1.325E-03	5.134E-03	8.547E+07	1.121E+02	4.203E-02	1.463E-02	5.666E-02
5914400	PR	3.882	.073	1.724	1.659	8.824E-02	1.430E-03	5.967E-02	8.586E+07	4.752E-03	6.427E-01	1.578E-02	6.585E-01
5914500	PR	1.569	.023	.673	1.222	2.354E-02	4.603E-04	2.400E-02	6.219E+07	3.491E-03	2.477E-01	4.365E-01	6.842E-01
5914600	PR	1.496	2.019	1.722	.870	2.245E-02	3.955E-02	6.200E-02	4.504E+07	3.491E-03	2.477E-01	4.365E-01	6.842E-01
6014700	ND	.355	.133	.229	.793	5.325E-03	2.615E-03	7.940E-03	4.101E+07	2.079E+00	5.876E-02	2.886E-02	8.762E-02
6114900	PM	.549	.016	.247	.786	8.233E-03	3.111E-04	8.544E-03	4.070E+07	4.153E-01	9.085E-02	3.433E-03	9.428E-02
6215300	SM	.296	.103	.194	.692	4.435E-03	2.009E-03	6.445E-03	3.579E+07	3.212E-01	4.895E-02	2.218E-02	7.112E-02
6315600	EU	.300	.702	.528	.374	4.495E-03	1.377E-02	1.826E-02	1.945E+07	1.364E+00	4.960E-02	1.519E-01	2.015E-01

TABLE B-XXXIII

TMI-2 IF OPERATED 26K HRS AT 2772. MW CONT. CINER-10(LASL) 8/79

30=TIME STEP
 3.60000E+03=TOTAL TIME SINCE LAST TIME AT POWER(S)
 9.34952E+07=TOTAL ELAPSED TIME(S)
 6.88811E+19=FISSIONS/S AT LAST TS AT POWER (22)
 2.77200E+09=POWER (WATTS) AT LAST TS AT POWER (2.77200E+03 MW)
 7.28678E+03=ACCUMULATED FISSIONS (FISSIONS PER BARN-CM)
 1.44045E+04=TOTAL FP IN SUM PER BARN-CM

1.52310E+20=TOTAL ACTIVITY (DYS/S)
 4.11650E+09=TOTAL CURIES
 1.11317E+01=TOTAL BETA DECAY POWER (MW)
 1.50362E+01=TOTAL GAMMA DECAY POWER (MW)
 2.61679E+01=TOTAL DECAY POWER (MW)
 1.00874E+00=TOTAL BETA MEV/F
 1.36256E+00=TOTAL GAMMA MEV/F
 2.37130E+00=TOTAL DECAY MEV/F

ID	SYM	PERCENT OF		ALL FP	CURIES	MEV/FISS			CURIES	DENSITY	DECAY POWER IN MW		
		BETA	GAMMA			TOTAL	BETA	GAMMA			TOTAL		
3604700	KR	1.108	.497	.751	.379	1.118E-02	6.639E-03	1.782E-02	1.559E+07	3.796E-03	1.234E-01	7.326E-02	1.966E-01
3608800	KR	.395	2.604	1.655	.726	3.988E-03	3.549E-02	3.947E-02	2.987E+07	1.607E-02	4.401E-02	3.916E-01	4.356E-01
3708800	RA	3.663	.877	2.042	.802	3.695E-02	1.196E-02	4.890E-02	3.303E+07	1.872E-03	4.077E-01	1.319E-01	5.396E-01
3808900	SR	1.618	0.000	.698	1.258	1.632E-02	0.	1.632E-02	5.221E+07	1.252E+01	1.801E-01	0.	1.801E-01
3807100	SR	2.168	1.711	1.925	1.515	2.187E-02	2.331E-02	4.515E-02	6.242E+07	1.137E-01	2.413E-01	2.573E-01	4.986E-01
3909100	Y	2.247	.007	.960	1.692	2.267E-02	9.950E-05	2.277E-02	6.964E+07	1.882E+01	2.502E-01	1.098E-03	2.513E-01
3904110	Y	0.000	.824	.475	.917	0.	1.126E-02	1.126E-02	3.775E+07	6.008E-03	0.	1.242E-01	1.242E-01
3809200	SR	.580	2.988	1.944	1.375	5.848E-03	4.072E-02	4.656E-02	5.661E+07	2.948E-02	6.453E-02	4.493E-01	5.138E-01
3909200	Y	5.605	.703	2.798	1.744	5.654E-02	9.594E-03	6.612E-02	7.188E+07	4.876E-02	6.239E-01	1.058E-01	7.297E-01
3907300	Y	5.198	.291	2.379	2.022	5.243E-02	3.965E-03	5.640E-02	8.241E+07	1.615E-01	5.786E-01	4.376E-02	6.224E-01
3909400	Y	1.012	.430	.478	.240	1.021E-02	5.863E-03	1.607E-02	1.107E+07	6.735E-04	1.127E-01	6.470E-02	1.774E-01
4009500	ZR	.637	2.984	1.986	2.499	6.424E-03	4.066E-02	4.709E-02	1.028E+08	3.106E+01	7.089E-02	4.487E-01	5.196E-01
4109500	NR	.242	2.155	1.916	2.538	2.445E-03	4.298E-02	4.543E-02	1.045E+08	1.691E+01	2.698E-02	4.743E-01	5.013E-01
4009700	ZR	3.808	.725	2.034	2.497	3.841E-02	9.874E-03	4.829E-02	1.011E+08	3.265E-01	4.239E-01	1.090E-01	5.329E-01
4109700	NB	2.620	2.405	2.727	2.594	2.643E-02	3.824E-02	6.467E-02	1.051E+08	2.478E-02	2.916E-01	4.220E-01	7.136E-01

Table with 15 columns representing various parameters and 60 rows of data points. Columns include alphanumeric codes (e.g., NH, MQ, TC, RU, RH) and numerical values in scientific notation.

TABLE B-XXXIV

TMI-? IF OPERATED 26K HRS AT 2772. MW CONT. CINER-10(LASL) 0/79

31=TIME STEP
7.20000E+03=TOTAL TIME SINCE LAST TIME AT POWER(S)
9.34988E+07=TOTAL ELAPSED TIME(S)

6.88811E+19=FISSIONS/S AT LAST TS AT POWER.(22)
 2.77200E+09=POWER (WATTS) AT LAST TS AT POWER (2.77200E+03 MW)
 7.28678E+03=ACCUMULATED FISSIONS (FISSIONS PER BARN-CM)
 1.44049E+04=TOTAL FP IN SUM PER BARN-CM

1.36000E+20=TOTAL ACTIVITY (DIS/S)
 3.67568E+09=TOTAL CURTES
 9.12636E+00=TOTAL BETA DECAY POWER (MW)
 1.19009E+01=TOTAL GAMMA DECAY POWER (MW)
 2.10272E+01=TOTAL DECAY POWER (MW)
 8.27019E-01=TOTAL BETA MEV/F
 1.07844E+00=TOTAL GAMMA MEV/F
 1.90546E+00=TOTAL DECAY MEV/F

ID ZZAAS	SYM	-----PERCENT OF ALL FP-----				-----MEV/FISS-----			CURIES	DENSITY	---DECAY POWER IN MW---		
		BETA	GAMMA	TOTAL	CURTES	BETA	GAMMA	TOTAL			BETA	GAMMA	TOTAL
3608700	KR	.782	.394	.541	.249	6.467E-03	3.841E-03	1.031E-02	9.022E+06	2.196E-03	7.137E-02	4.239E-02	1.138E-01
3608800	KR	.376	2.569	1.617	.634	3.114E-03	2.770E-02	3.082E-02	2.332E+07	1.255E-02	3.436E-02	3.057E-01	3.401E-01
3708800	RB	3.521	.874	2.023	.778	2.912E-02	9.423E-03	3.854E-02	2.603E+07	1.476E-03	3.213E-01	1.040E-01	4.253E-01
3808900	SR	1.973	0.000	.496	1.420	1.631E-02	0.	1.631E-02	5.218E+07	1.251E+01	1.800E-01	0.	1.800E-01
3809100	SR	2.458	2.000	2.214	1.578	2.033E-02	2.167E-02	4.200E-02	5.801E+07	1.057E-01	2.243E-01	2.391E-01	4.635E-01
3909100	Y	2.741	.009	1.135	1.894	2.267E-02	9.950E-05	2.277E-02	6.964E+07	1.882E+01	2.501E-01	1.098E-03	2.512E-01
3909110	Y	0.000	.992	.551	.976	0.	1.070E-02	1.070E-02	3.587E+07	5.710E-03	0.	1.180E-01	1.180E-01
3809200	SR	.548	2.923	1.822	1.193	4.528E-03	3.153E-02	3.605E-02	4.384E+07	2.283E-02	4.997E-02	3.479E-01	3.979E-01
3909200	Y	6.461	.840	3.290	1.848	5.343E-02	9.058E-03	6.249E-02	6.794E+07	4.608E-02	5.897E-01	9.996E-02	6.896E-01
3909300	Y	5.924	.344	2.756	2.095	4.899E-02	3.705E-03	5.270E-02	7.700E+07	1.509E-01	5.406E-01	4.088E-02	5.815E-01
4009500	ZR	.776	3.749	2.470	2.796	6.421E-03	4.064E-02	4.706E-02	1.028E+08	3.105E+01	7.085E-02	4.485E-01	5.193E-01
4109500	NB	.296	3.986	2.394	2.443	2.445E-03	4.298E-02	4.543E-02	1.045E+08	1.691E+01	2.698E-02	4.743E-01	5.013E-01
4009700	ZR	4.457	.877	2.432	2.640	3.686E-02	9.474E-03	4.634E-02	9.705E+07	3.133E-01	4.068E-01	1.046E-01	5.113E-01
4109700	NB	3.114	3.444	3.378	2.788	2.576E-02	3.727E-02	6.302E-02	1.025E+08	2.416E-02	2.842E-01	4.112E-01	4.635E-01
4109710	NB	0.000	3.097	1.793	2.278	0.	3.340E-02	3.340E-02	8.373E+07	2.413E-04	0.	3.686E-01	3.686E-01
4209900	MO	2.825	1.048	1.819	3.076	2.337E-02	1.130E-02	3.466E-02	1.131E+08	1.434E+00	2.578E-01	1.247E-01	3.825E-01
4309910	TC	0.000	.707	.470	2.729	0.	7.622E-03	7.622E-03	9.941E+07	1.150E-01	0.	8.411E-02	8.411E-02
4410300	RU	.479	2.464	1.716	2.970	3.959E-03	2.873E-02	3.269E-02	1.092E+08	1.993E+01	4.369E-02	3.170E-01	3.607E-01
4510310	RH	0.000	.216	.122	2.972	0.	2.334E-03	2.334E-03	1.092E+08	1.959E-02	0.	2.576E-02	2.576E-02
4410500	RU	1.552	2.271	1.959	1.575	1.283E-02	2.449E-02	3.733E-02	5.789E+07	4.940E-02	1.416E-01	2.703E-01	4.119E-01
4510500	RH	.710	.282	.448	1.953	5.873E-03	3.038E-03	8.911E-03	7.180E+07	4.898E-01	6.481E-02	3.352E-02	9.834E-02
4410600	RU	.028	0.000	.012	1.159	2.279E-04	0.	2.279E-04	4.255E+07	7.242E+01	2.515E-03	0.	2.515E-03
4510600	RH	3.996	.423	1.973	1.158	3.304E-02	4.559E-03	3.760E-02	4.255E+07	6.792E-05	3.646E-01	5.031E-02	4.150E-01
4610900	PD	.465	.000	.272	.535	3.848E-03	2.219E-06	3.850E-03	1.967E+07	5.089E-02	4.246E-02	2.449E-05	4.249E-02
4710910	AG	0.000	.088	.048	.531	0.	9.203E-04	9.203E-04	1.954E+07	4.130E-05	0.	1.016E-02	1.016E-02
5112900	SB	.378	1.049	.758	.441	3.124E-03	1.132E-02	1.444E-02	1.620E+07	1.351E-02	3.447E-02	1.249E-01	1.594E-01
5212900	TE	.642	.067	.317	.504	5.310E-03	7.250E-04	6.035E-03	1.851E+07	4.151E-03	5.860E-02	8.001E-03	6.660E-02
5213110	TE	.111	.700	.444	.256	9.218E-04	7.545E-03	8.466E-03	9.419E+06	5.430E-02	1.017E-02	8.326E-02	9.343E-02
5313100	I	.768	1.236	1.033	1.734	6.349E-03	1.332E-02	1.967E-02	6.372E+07	2.363E+00	7.007E-02	1.470E-01	2.171E-01
5213200	TE	.347	1.191	.825	2.422	2.871E-03	1.284E-02	1.571E-02	8.902E+07	1.334E+00	3.169E-02	1.417E-01	1.734E-01
5313200	I	3.106	10.157	7.077	2.479	2.568E-02	1.095E-01	1.352E-01	9.113E+07	4.002E-02	2.834E-01	1.209E+00	1.492E+00
5213310	TF	.351	.911	.658	.267	2.906E-03	9.824E-03	1.273E-02	9.801E+06	1.739E-03	3.207E-02	1.084E-01	1.405E-01
5313300	I	3.281	3.612	3.450	3.295	2.714E-02	3.896E-02	6.609E-02	1.211E+08	4.840E-01	2.995E-01	4.299E-01	7.294E-01
5413300	XE	.851	.521	.654	3.497	7.034E-03	5.623E-03	1.266E-02	1.285E+08	3.136E+00	7.762E-02	6.205E-02	1.397E-01
5213400	TE	.126	.525	.352	.347	1.043E-03	5.657E-03	6.700E-03	1.277E+07	1.717E-03	1.151E-02	6.243E-02	7.393E-02
5313400	I	2.376	8.838	4.901	1.441	1.965E-02	7.374E-02	9.339E-02	5.295E+07	8.920E-03	2.169E-01	8.138E-01	1.031E+00
5513400	CS	.148	1.110	.622	.384	1.222E-03	1.197E-02	1.319E-02	1.410E+07	4.894E+01	1.348E-02	1.320E-01	1.455E-01
5313500	I	2.442	6.927	4.991	2.599	2.020E-02	7.471E-02	9.491E-02	9.552E+07	1.209E-01	2.229E-01	8.244E-01	1.047E+00
5413500	XE	.703	.455	.552	.950	5.812E-03	4.903E-03	1.071E-02	3.491E+07	6.152E-02	6.414E-02	5.411E-02	1.182E-01
5513800	CS	1.134	1.604	1.400	.374	9.378E-03	1.730E-02	2.668E-02	1.383E+07	1.426E-03	1.035E-01	1.909E-01	2.944E-01
5613900	BA	2.667	.119	1.225	1.245	2.206E-02	1.286E-03	2.334E-02	4.577E+07	1.221E-02	2.434E-01	1.419E-02	2.576E-01

5614000	RA	1.236	1.140	1.471	2.894	1.602E-02	1.239E-02	2.841E-02	1.064E+08	6.275E+00	1.767E-01	1.368E-01	3.135E-01
5714000	LA	3.757	12.818	9.885	3.044	3.107E-02	1.382E-01	1.693E-01	1.119E+08	8.650E-01	3.429E-01	1.525E+00	1.868E+00
5714100	LA	4.975	.125	2.231	2.125	4.114E-02	1.364E-03	4.251E-02	7.738E+07	5.755E-02	4.540E-01	1.505E-02	4.691E-01
5814100	CF	1.059	.765	.655	2.781	4.757E-03	3.937E-03	1.269E-02	1.022E+08	1.534E+01	9.664E-02	4.344E-02	1.401E-01
5714200	LA	2.767	5.379	4.265	1.224	2.289E-02	5.800E-02	8.089E-02	4.499E+07	1.331E-02	2.526E-01	6.400E-01	8.926E-01
5814300	CE	2.433	1.717	1.901	2.431	2.012E-02	1.420E-02	3.432E-02	8.937E+07	5.667E-01	2.220E-01	1.567E-01	3.787E-01
5914300	PR	1.234	0.070	.839	2.571	1.600E-02	0.	1.600E-02	9.193E+07	5.757E+00	1.765E-01	0.	1.765E-01
5814400	CF	.460	.123	.259	2.325	3.808E-03	1.325E-03	5.133E-03	8.546E+07	1.121E+02	4.202E-02	1.462E-02	5.665E-02
5914400	PR	7.010	.132	3.117	2.325	5.797E-02	1.424E-03	5.940E-02	8.547E+07	4.730E-03	6.397E-01	1.571E-02	6.555E-01
5914500	PR	2.332	.035	1.032	1.385	1.929E-02	3.772E-04	1.966E-02	5.095E+07	5.855E-02	2.128E-01	4.162E-03	2.170E-01
6014700	ND	.641	.241	.415	1.111	5.302E-03	2.604E-03	7.907E-03	4.084E+07	2.070E+00	5.851E-02	2.874E-02	8.725E-02
6114800	PM	.666	.433	.534	.375	5.509E-03	4.665E-03	1.017E-02	1.378E+07	3.413E-01	6.079E-02	5.148E-02	1.123E-01
6114900	PM	.282	.029	.442	1.022	8.123E-03	3.069E-04	8.430E-03	4.016E+07	4.097E-01	8.964E-02	3.387E-03	9.302E-02
6215300	SM	.523	.182	.330	.949	4.324E-03	1.959E-03	6.293E-03	3.489E+07	3.131E-01	4.771E-02	2.162E-02	6.933E-02
6315600	EU	.542	1.273	.956	.528	4.481E-03	1.373E-02	1.821E-02	1.939E+07	1.359E+00	4.945E-02	1.515E-01	2.009E-01

TABLE B-XXXV

TMI-2 IF OPERATED 26K HRS AT 2772. MW CONT. CINDER-10(LASL) 8/79

32=TIME STEP
 1.80000E+04=TOTAL TIME SINCE LAST TIME AT POWER(S)
 9.35096E+07=TOTAL ELAPSED TIME(S)
 6.88811E+19=FISSIONS/S AT LAST TS AT POWER (22)
 2.77200E+09=POWER (WATTS) AT LAST TS AT POWER (2.77200E+03 MW)
 7.28678E+03=ACCUMULATED FISSIONS (FISSIONS PER BARN-CM)
 1.44045E+04=TOTAL FP IN SUM PER BARN-CM

1.17988E+20=TOTAL ACTIVITY (DIS/S)
 3.18888E+09=TOTAL CURIES
 7.12957E+00=TOTAL BETA DECAY POWER (MW)
 8.96140E+00=TOTAL GAMMA DECAY POWER (MW)
 1.60910E+01=TOTAL DECAY POWER (MW)
 6.46073E-01=TOTAL BETA MEV/F
 8.12071E-01=TOTAL GAMMA MEV/F
 1.45814E+00=TOTAL DECAY MEV/F

ID	SYM	PERCENT OF ALL FP				MEV/FISS			DECAY POWER IN MW				
		BETA	GAMMA	TOTAL	CURIES	BETA	GAMMA	TOTAL	CURIES	DENSITY	BETA	GAMMA	TOTAL
3608800	KR	.229	1.523	1.076	.348	1.482E-03	1.318E-02	1.466E-02	1.110E+07	5.970E-03	1.635E-02	1.455E-01	1.618E-01
3708800	RB	2.148	.553	1.289	.399	1.387E-02	4.490E-03	1.836E-02	1.240E+07	7.031E-04	1.531E-01	4.955E-02	2.027E-01
3808900	SR	2.521	0.000	1.117	1.634	1.629E-02	0.	1.629E-02	5.210E+07	1.249E+01	1.797E-01	0.	1.797E-01
3909000	Y	.511	.000	.226	.207	3.299E-03	9.921E-07	3.300E-03	6.596E+06	8.123E-02	3.640E-02	1.095E-05	3.641E-02
3809100	SR	2.527	2.143	2.913	1.461	1.632E-02	1.740E-02	3.373E-02	4.659E+07	8.487E-02	1.801E-01	1.920E-01	3.722E-01
3909100	Y	3.507	.012	1.541	2.193	2.266E-02	9.947E-05	2.276E-02	6.961E+07	1.881E+01	2.501E-01	1.098E-03	2.512E-01
3909110	Y	0.000	1.076	.539	.919	0.	8.737E-03	8.737E-03	2.930E+07	4.664E-03	0.	9.641E-02	9.641E-02
3809200	SR	.325	1.902	1.148	.638	2.102E-03	1.464E-02	1.674E-02	2.035E+07	1.080E-02	2.320E-02	1.615E-01	1.847E-01
3909200	Y	6.186	.934	3.206	1.594	3.997E-02	6.775E-03	4.674E-02	5.082E+07	3.447E-02	4.411E-01	7.477E-02	5.158E-01
3909300	Y	6.184	.372	2.967	1.949	3.996E-02	3.021E-03	4.298E-02	6.280E+07	1.231E-01	4.409E-01	3.334E-02	4.743E-01
4009500	ZR	.293	4.998	3.223	3.219	6.412E-03	4.059E-02	4.700E-02	1.027E+08	3.101E+01	7.076E-02	4.479E-01	5.187E-01
4109500	NR	.378	1.293	3.114	3.277	2.445E-03	4.298E-02	4.943E-02	1.045E+08	1.691E+01	2.698E-02	4.743E-01	5.013E-01
4009700	ZR	5.041	1.231	2.839	2.699	3.257E-02	8.371E-03	4.094E-02	8.575E+07	2.768E-01	3.594E-01	9.238E-02	4.518E-01
4109700	NB	3.585	4.127	3.997	2.890	2.316E-02	3.351E-02	5.669E-02	9.215E+07	2.172E-02	2.556E-01	3.698E-01	6.254E-01

4109710	NR	0.000	3.634	2.024	2.329	0.	2.951E-02	2.951E-02	7.398E+07	2.132E-04	0.	3.257E-01	3.257E-01
4209900	NO	3.504	1.344	2.324	3.439	2.264E-02	1.095E-07	3.359E-02	1.096E+08	1.390E+00	2.498E-01	1.208E-01	3.707E-01
4309910	TC	0.000	.929	.517	3.046	0.	7.545E-03	7.545E-03	9.840E+07	1.138E-01	0.	8.326E-02	8.326E-02
4410300	RU	.611	3.430	2.737	3.415	3.951E-03	2.867E-02	3.262E-02	1.089E+08	1.989E+01	4.360E-02	3.164E-01	3.600E-01
4510310	RH	0.000	.287	.140	3.419	0.	2.329E-03	2.329E-03	1.090E+08	1.955E-02	0.	2.571E-02	2.571E-02
4610500	RH	1.243	1.889	1.623	1.137	8.033E-03	1.533E-02	2.337E-02	3.624E+07	3.092E-02	8.865E-02	1.692E-01	2.579E-01
4510500	RU	.890	.366	.529	2.225	5.752E-03	2.976E-03	8.728E-03	7.032E+07	4.797E-01	6.348E-02	3.284E-02	9.632E-02
4410600	RU	.035	0.000	.014	1.334	2.278E-04	0.	2.278E-04	4.254E+07	7.240E+01	2.514E-03	0.	2.514E-03
4510600	RH	5.113	.551	2.578	1.334	3.304E-02	4.558E-03	3.759E-02	4.254E+07	6.790E-05	3.646E-01	5.029E-02	4.149E-01
4610900	PD	.510	.000	.226	.529	3.297E-03	1.902E-06	3.299E-03	1.686E+07	4.360E-02	3.638E-02	2.098E-05	3.640E-02
4710910	AG	0.000	.097	.054	.525	0.	7.886E-04	7.886E-04	1.674E+07	3.538E-05	0.	8.702E-03	8.702E-03
5112900	SR	.299	.963	.613	.315	1.935E-03	7.010E-03	8.944E-03	1.003E+07	8.365E-03	2.135E-02	7.735E-02	9.870E-02
5212900	TE	.605	.066	.325	.427	3.909E-03	5.337E-04	4.443E-03	1.363E+07	3.056E-03	4.314E-02	5.889E-03	4.903E-02
5213110	TE	.133	.867	.542	.276	8.602E-04	7.040E-03	7.900E-03	8.790E+06	5.067E-02	9.492E-03	7.769E-02	8.718E-02
5313100	I	.974	1.624	1.337	1.980	6.293E-03	1.321E-02	1.950E-02	6.315E+07	2.342E+00	6.944E-02	1.457E-01	2.152E-01
5213200	TE	.433	1.540	1.049	2.718	2.796E-03	1.251E-02	1.530E-02	8.668E+07	1.299E+00	3.085E-02	1.380E-01	1.689E-01
5313200	I	3.885	13.182	9.063	2.793	2.510E-02	1.071E-01	1.322E-01	8.906E+07	3.911E-02	2.770E-01	1.181E+00	1.458E+00
5313300	I	3.814	4.354	4.116	3.444	2.464E-02	3.537E-02	6.001E-02	1.100E+08	4.395E-01	2.719E-01	3.903E-01	6.622E-01
5413300	XE	1.047	.691	.847	4.025	7.025E-03	5.615E-03	1.264E-02	1.284E+08	3.132E+00	7.752E-02	6.197E-02	1.395E-01
5313400	I	.405	1.210	.854	.221	2.620E-03	9.830E+03	1.245E-02	7.059E+06	1.189E-03	2.891E-02	1.085E-01	1.374E-01
5513400	CS	.189	1.473	.904	.442	1.222E-03	1.196E-02	1.319E-02	1.410E+07	4.893E+01	1.348E-02	1.320E-01	1.455E-01
5313500	I	2.280	6.709	4.744	2.184	1.473E-02	5.448E-02	6.921E-02	6.966E+07	8.814E-02	1.625E-01	6.012E-01	7.637E-01
5413500	XE	1.145	.765	.935	1.393	7.397E-03	6.240E-03	1.364E-02	4.444E+07	7.830E-02	8.163E-02	6.886E-02	1.505E-01
5613900	BA	.764	.035	.358	.321	4.933E-03	2.875E-04	5.221E-03	1.024E+07	2.731E-03	5.444E-02	3.172E-03	5.761E-02
5614000	BA	2.462	1.516	1.935	3.313	1.591E-02	1.231E-02	2.822E-02	1.057E+08	6.233E+00	1.755E-01	1.358E-01	3.114E-01
5714000	LA	4.797	11.977	11.590	3.499	3.099E-02	1.379E-01	1.689E-01	1.116E+08	8.627E-01	3.420E-01	1.521E+00	1.863E+00
5714100	LA	3.726	.098	1.725	1.420	2.407E-02	7.978E-04	2.487E-02	4.527E+07	3.367E-02	2.656E-01	8.804E-03	2.744E-01
5814100	CE	1.354	.484	.870	3.202	8.748E-03	3.933E-03	1.268E-02	1.021E+08	1.532E+01	9.653E-02	4.340E-02	1.399E-01
5714200	LA	.918	1.851	1.439	.366	5.932E-03	1.503E-02	2.097E-02	1.166E+07	3.451E-03	6.546E-02	1.659E-01	2.314E-01
5814300	CE	2.924	1.642	2.210	2.631	1.889E-02	1.333E-02	3.223E-02	8.391E+07	5.321E-01	2.085E-01	1.471E-01	3.556E-01
5914300	PR	2.475	0.000	1.037	2.882	1.599E-02	0.	1.599E-02	9.189E+07	5.755E+00	1.764E-01	0.	1.764E-01
5814400	CE	.589	.163	.352	2.679	3.807E-03	1.325E-03	5.132E-03	8.543E+07	1.121E+02	4.201E-02	1.462E-02	5.663E-02
5914400	PR	8.970	.175	4.072	2.679	5.795E-02	1.423E-03	5.937E-02	8.543E+07	4.728E-03	6.395E-01	1.570E-02	6.552E-01
5914500	PR	2.108	.033	.952	1.129	1.362E-02	2.664E-04	1.389E-02	3.599E+07	4.136E-02	1.503E-01	2.940E-03	1.533E-01
6014700	NO	.814	.319	.538	1.271	5.261E-03	2.584E-03	7.844E-03	4.052E+07	2.054E+00	5.805E-02	2.851E-02	8.657E-02
6114800	PM	.839	.565	.697	.425	5.421E-03	4.591E-03	1.001E-02	1.356E+07	3.358E-01	5.983E-02	5.067E-02	1.105E-01
6114900	PM	1.217	.037	.550	1.219	7.862E-03	2.971E-04	8.159E-03	3.886E+07	3.966E-01	8.675E-02	3.278E-03	9.003E-02
6215300	SH	.640	.231	.412	1.046	4.135E-03	1.874E-03	6.009E-03	3.337E+07	2.995E-01	4.563E-02	2.068E-02	6.631E-02
6315600	EU	.690	1.681	1.242	.625	4.457E-03	1.365E-02	1.811E-02	1.929E+07	1.352E+00	4.919E-02	1.507E-01	1.999E-01

TABLE B-XXXVI

TMI-2 IF OPERATED 26K HRS AT 2772. MW CONT. C1NER-10(LASL) 8/79

33=TIME STEP
 3.60000E+04=TOTAL TIME SINCE LAST TIME AT POWER(S)
 9.35276E+07=TOTAL ELAPSED TIME(S)
 6.88811E+19=FISSIONS/S AT LAST TS AT POWER.(22)
 2.77200E+09=POWER (WATTS) AT LAST TS AT POWER (2.77200E+03 MW)
 7.28678E+03=ACCUMULATED FISSIONS (FISSIONS PER BARN-CM)
 1.44045E+04=TOTAL FP IN SIM PER BARN-CM

1.04429E+20=TOTAL ACTIVITY (DTS/S)
 2.82240E+09=TOTAL CURIES
 5.80154E+00=TOTAL BETA DECAY POWER (MW)

7.52075E+00=TOTAL GAMMA DECAY POWER (MW)
 1.33223E+01=TOTAL DECAY POWER (MW)
 5.29729E-01=TOTAL BETA MFV/F
 6.81521E-01=TOTAL GAMMA MFV/F
 1.20725E+00=TOTAL DECAY MEV/F

ID ZZAAS	SYM	PERCENT OF ALL FP				MEV/FISS				DECAY POWER IN MW			
		BETA	GAMMA	TOTAL	CURIES	BETA	GAMMA	TOTAL	CURIES	DENSITY	BETA	GAMMA	TOTAL
3608800	KR	.082	.541	.352	.114	4.297E-04	3.823E-03	4.293E-03	3.218E+06	1.732E-03	4.742E-03	4.219E-02	4.693E-02
3708800	RR	.769	.191	.441	.127	4.024E-03	1.302E-03	5.326E-03	3.597E+06	2.039E-04	4.441E-02	1.437E-02	5.878E-02
3808900	SR	3.089	0.000	1.345	1.841	1.624E-02	0.	1.624E-02	5.195E+07	1.246E+01	1.792E-01	0.	1.792E-01
3909000	Y	.626	.000	.273	.233	7.290E-03	9.894E-07	3.291E-03	6.580E+06	8.102E-02	3.631E-02	1.092E-03	3.632E-02
3809100	SR	2.154	1.777	1.938	1.145	1.133E-02	1.207E-02	2.340E-02	3.232E+07	5.888E-02	1.250E-01	1.332E-01	2.582E-01
3909100	Y	4.306	.015	1.893	2.464	2.264E-02	9.937E-05	2.274E-02	6.954E+07	1.890E+01	2.498E-01	1.097E-03	2.509E-01
3909110	Y	0.000	.891	.573	.777	0.	6.073E-03	6.073E-03	2.036E+07	3.242E-03	0.	6.702E-02	6.702E-02
3809200	SR	.111	.599	.396	.231	5.851E-04	4.074E-03	4.659E-03	5.665E+06	2.950E-03	6.457E-03	4.496E-02	5.142E-02
3909200	Y	3.817	.499	1.944	.974	7.007E-02	3.402E-03	2.347E-02	2.551E+07	1.731E-02	2.215E-01	3.754E-02	2.590E-01
3909300	Y	5.411	.316	2.534	1.544	2.845E-02	2.151E-03	3.060E-02	4.471E+07	8.763E-02	3.139E-01	2.374E-02	3.376E-01
4009500	ZR	1.217	5.947	3.845	3.429	6.398E-03	4.050E-02	4.690E-02	1.024E+08	3.094E+01	7.061E-02	4.469E-01	5.175E-01
4104500	NB	.465	6.706	3.753	3.772	7.445E-03	4.298E-02	4.942E-02	1.045E+08	1.691E+01	2.698E-02	4.743E-01	5.013E-01
4004700	ZR	5.040	.999	2.749	2.472	7.650E-02	6.811E-03	3.331E-02	6.976E+07	2.252E-01	2.924E-01	7.516E-02	3.676E-01
4109700	NB	3.600	4.018	3.836	2.649	1.893E-02	2.738E-02	4.631E-02	7.529E+07	1.775E-02	2.088E-01	3.022E-01	5.110E-01
4109710	NB	0.000	3.523	1.949	2.133	0.	2.401E-02	2.401E-02	6.019E+07	1.735E-04	0.	2.650E-01	2.650E-01
4209900	MD	4.086	1.574	2.640	3.643	7.148E-02	1.039E-02	3.187E-02	1.039E+08	1.319E+00	2.371E-01	1.146E-01	3.517E-01
4309910	TC	0.000	1.075	.677	3.345	0.	7.326E-03	7.326E-03	9.554E+07	1.105E-01	0.	8.084E-02	8.084E-02
4410300	RU	.749	4.191	2.672	3.843	3.936E-03	2.856E-02	3.250E-02	1.085E+08	1.982E+01	4.344E-02	3.152E-01	3.586E-01
4510310	RH	0.000	.341	.172	3.449	0.	2.321E-03	2.321E-03	1.086E+08	1.948E-02	0.	2.561E-02	2.561E-02
4410500	RU	.700	1.031	.897	.584	3.680E-03	7.025E-03	1.071E-02	1.660E+07	1.417E-02	4.061E-02	7.753E-02	1.181E-01
4510500	RH	1.028	.410	.690	2.342	5.407E-03	2.797E-03	8.203E-03	6.610E+07	4.509E-01	5.966E-02	3.086E-02	9.052E-02
4410600	RH	.043	0.000	.019	1.507	7.277E-04	0.	2.277E-04	4.253E+07	7.237E+01	2.513E-03	0.	2.513E-03
4510600	RH	6.281	.649	3.113	1.507	3.302E-02	4.556E-03	3.758E-02	4.253E+07	6.787E-05	3.644E-01	5.027E-02	4.147E-01
5213110	TE	.146	.970	.593	.277	7.663E-04	6.272E-03	7.039E-03	7.831E+06	4.514E-02	8.457E-03	6.922E-02	7.767E-02
5313100	I	1.178	1.909	1.530	2.233	6.196E-03	1.300E-02	1.920E-02	6.218E+07	2.306E+00	6.837E-02	1.435E-01	2.118E-01
5213200	TE	.509	1.745	1.212	2.994	7.674E-03	1.196E-02	1.464E-02	8.291E+07	1.243E+00	2.951E-02	1.320E-01	1.615E-01
5313200	I	4.576	15.055	10.472	3.024	2.406E-02	1.026E-01	1.267E-01	8.536E+07	3.748E-02	2.655E-01	1.132E+00	1.398E+00
5313300	I	3.969	4.396	4.210	3.299	2.087E-02	2.996E-02	5.082E-02	9.312E+07	3.722E-01	2.303E-01	3.306E-01	5.609E-01
5413300	XE	1.329	.970	1.942	4.525	6.989E-03	5.587E-03	1.259E-02	1.277E+08	3.116E+00	7.713E-02	6.165E-02	1.388E-01
5513400	CS	.232	1.745	1.092	.499	1.221E-03	1.196E-02	1.318E-02	1.410E+07	4.892E+01	1.348E-02	1.320E-01	1.455E-01
5313500	I	1.655	4.722	3.347	1.454	7.702E-03	3.218E-02	4.089E-02	4.115E+07	5.207E-02	9.602E-02	3.552E-01	4.512E-01
5413500	XE	1.498	.975	1.272	1.674	7.874E-03	6.643E-03	1.452E-02	4.730E+07	8.336E-02	8.689E-02	7.330E-02	1.602E-01
5513600	CS	.038	.575	.312	.109	1.976E-04	3.575E-03	3.772E-03	3.085E+06	1.849E-01	2.180E-03	3.945E-02	4.163E-02
5614000	BA	2.992	1.786	2.311	3.772	1.573E-02	1.217E-02	2.790E-02	1.045E+08	6.163E+00	1.736E-01	1.343E-01	3.079E-01
5714000	LA	5.866	20.131	13.919	3.935	3.084E-02	1.372E-01	1.680E-01	1.111E+08	8.585E-01	3.403E-01	1.514E+00	1.854E+00
5714100	LA	1.870	.048	.841	.655	9.830E-03	3.258E-04	1.016E-02	1.849E+07	1.375E-02	1.085E-01	3.595E-03	1.121E-01
5814100	CE	1.659	.575	1.047	3.604	9.720E-03	3.920E-03	1.264E-02	1.018E+08	1.527E+01	9.623E-02	4.326E-02	1.395E-01
5814300	CE	3.235	1.761	2.473	2.677	1.701E-02	1.200E-02	2.901E-02	7.554E+07	4.791E-01	1.877E-01	1.325E-01	3.202E-01
5914300	PR	3.037	0.000	1.373	3.251	1.597E-02	0.	1.597E-02	9.177E+07	5.747E+00	1.762E-01	0.	1.762E-01
5814400	CE	.774	.194	.425	1.025	3.805E-03	1.324E-03	5.129E-03	8.539E+07	1.120E+02	4.199E-02	1.461E-02	5.660E-02
5914400	PR	11.017	.209	4.916	3.025	5.792E-02	1.422E-03	5.934E-02	8.539E+07	4.726E-03	6.392E-01	1.570E-02	6.549E-01
5914500	PR	1.451	.072	.644	.714	7.630E-03	1.492E-04	7.779E-03	2.016E+07	2.317E-02	8.420E-02	1.647E-03	8.585E-02
6014700	ND	.988	.374	.641	1.417	5.192E-03	2.550E-03	7.742E-03	3.999E+07	2.027E+00	5.730E-02	2.814E-02	8.544E-02
6114800	PM	1.004	.646	.878	.468	5.279E-03	4.471E-03	9.750E-03	1.320E+07	3.270E-01	5.825E-02	4.934E-02	1.076E-01
6114900	PM	1.404	.041	.635	1.233	7.383E-03	2.790E-04	7.662E-03	3.650E+07	3.725E-01	8.148E-02	3.079E-02	8.456E-02
6215300	SM	.730	.255	.442	1.099	7.840E-03	1.740E-03	5.579E-03	3.098E+07	2.781E-01	4.237E-02	1.920E-02	6.157E-02
6315600	EU	.840	1.985	1.447	.677	4.417E-03	1.353E-02	1.795E-02	1.912E+07	1.340E+00	4.875E-02	1.493E-01	1.981E-01

TABLE B-XXXVII

TMT-2 IF OPERATED 26K HRS AT 2772. MW CONT. C1NER-10(LASL) 8/79

34=TIME STEP
 7.20000E+04=TOTAL TIME SINCE LAST TIME AT POWER(S)
 9.35636E+07=TOTAL ELAPSED TIME(S)
 6.88811E+19=FISSIONS/S AT LAST TS AT POWER, (22)
 2.77200E+09=POWER (WATTS) AT LAST TS AT POWER (2.77200E+03 MW)
 7.28679E+03=ACCUMULATED FISSIONS (FISSIONS PER BARN-CM)
 1.44043E+04=TOTAL FP IN SIM PER BARN-CM

9.03368E+19=TOTAL ACTIVITY (DTS/S)
 2.44153E+09=TOTAL CURIES
 4.64695E+00=TOTAL BETA DECAY POWER (MW)
 6.34350E+00=TOTAL GAMMA DECAY POWER (MW)
 1.09905E+01=TOTAL DECAY POWER (MW)
 4.21101E-01=TOTAL BETA MEV/F
 3.74840E-01=TOTAL GAMMA MEV/F
 9.95941E-01=TOTAL DECAY MEV/F

ID ZZAAAS	SYM	-----PERCENT OF ALL FP-----				-----MEV/FISS-----			CURIES	DENSITY	---DECAY POWER IN MW---		
		BETA	GAMMA	TOTAL	CURIES	BETA	GAMMA	TOTAL			BETA	GAMMA	TOTAL
3808900	SR	3.936	0.000	1.622	2.116	1.615E-02	0.	1.615E-02	5.166E+07	1.239E+01	1.782E-01	0.	1.782E-01
3909000	Y	.778	.000	.729	.268	3.275E-03	9.850E-07	3.276E-03	6.549E+06	8.064E-02	3.614E-02	1.087E-05	3.615E-02
3809100	SR	1.295	1.011	1.131	.637	5.451E-03	5.812E-03	1.126E-02	1.556E+07	2.834E-02	6.016E-02	6.413E-02	1.243E-01
3909100	Y	5.359	.017	2.276	2.839	2.256E-02	9.905E-05	2.266E-02	6.932E+07	1.874E+01	2.490E-01	1.093E-03	2.501E-01
3909110	Y	0.000	.539	.234	.402	0.	2.923E-03	2.923E-03	9.803E+06	1.560E-03	0.	3.226E-02	3.226E-02
3909200	Y	.889	.110	.439	.195	3.742E-03	6.344E-04	4.377E-03	4.758E+06	3.228E-03	4.130E-02	7.001E-03	4.830E-02
3909300	Y	3.424	.190	1.557	.928	1.442E-02	1.090E-03	1.551E-02	2.266E+07	4.442E-02	1.591E-01	1.203E-02	1.711E-01
4009500	ZR	1.513	7.014	4.698	4.177	6.370E-03	4.032E-02	4.669E-02	1.020E+08	3.081E+01	7.029E-02	4.449E-01	5.152E-01
4109500	NR	.580	7.475	4.550	4.278	2.444E-03	4.297E-02	4.542E-02	1.045E+08	1.691E+01	2.697E-02	4.742E-01	5.012E-01
4009700	ZR	4.165	.784	2.214	1.891	1.754E-02	4.508E-03	2.205E-02	4.618E+07	1.491E-01	1.936E-01	4.975E-02	2.433E-01
4109700	NR	2.976	3.154	3.079	2.042	1.253E-02	1.813E-02	3.066E-02	4.985E+07	1.175E-02	1.383E-01	2.001E-01	3.384E-01
4109710	NR	0.000	2.755	1.526	1.632	0.	1.589E-02	1.589E-02	3.984E+07	1.148E-04	0.	1.754E-01	1.754E-01
4209900	MP	4.593	1.627	2.891	3.933	1.934E-02	9.354E-03	2.870E-02	9.359E+07	1.187E+00	2.134E-01	1.032E-01	3.167E-01
4309910	TC	0.000	1.172	.678	3.529	0.	6.737E-03	6.737E-03	8.787E+07	1.017E-01	0.	7.435E-02	7.435E-02
4410300	RU	.928	4.933	3.240	4.412	3.908E-03	2.836E-02	3.226E-02	1.077E+08	1.967E+01	4.312E-02	3.129E-01	3.560E-01
4510310	RH	0.000	.401	.231	4.417	0.	2.304E-03	2.304E-03	1.078E+08	1.934E-02	0.	2.543E-02	2.543E-02
4510500	RH	1.084	.411	.626	2.284	4.566E-03	2.362E-03	6.928E-03	5.582E+07	3.808E-01	5.039E-02	2.606E-02	7.645E-02
4410600	RU	.054	0.000	.023	1.740	2.276E-04	0.	2.276E-04	4.249E+07	7.232E+01	2.511E-03	0.	2.511E-03
4510600	RH	7.836	.792	3.770	1.740	3.300E-02	4.552E-03	3.755E-02	4.249E+07	6.782E-05	3.641E-01	5.024E-02	4.144E-01
4711000	AG	.616	.014	.270	1.68	2.593E-03	9.143E-05	2.685E-03	4.092E+06	4.755E+00	2.862E-02	1.009E-03	2.963E-02
5213110	TE	.144	.866	.551	.255	6.082E-04	4.978E-03	5.586E-03	6.215E+06	3.583E-02	6.712E-03	5.494E-02	6.165E-02
5313100	I	1.425	2.191	1.857	2.457	6.002E-03	1.259E-02	1.860E-02	6.023E+07	2.234E+00	6.623E-02	1.390E-01	2.052E-01
5213200	TE	.581	1.904	1.345	3.127	2.447E-03	1.094E-02	1.339E-02	7.586E+07	1.137E+00	2.700E-02	1.208E-01	1.478E-01
5313200	I	5.230	14.340	11.643	3.221	2.202E-02	9.393E-02	1.160E-01	7.815E+07	3.431E-02	2.430E-01	1.037E+00	1.280E+00
5313300	I	3.551	3.734	3.657	2.733	1.495E-02	2.147E-02	3.642E-02	6.673E+07	2.667E-01	1.650E-01	2.369E-01	4.019E-01
5413300	XE	1.628	.954	1.239	5.132	4.857E-03	5.482E-03	1.234E-02	1.253E+08	3.057E+00	7.567E-02	6.049E-02	1.362E-01
5513400	CS	.290	2.088	1.323	.577	1.221E-03	1.196E-02	1.318E-02	1.409E+07	4.890E+01	1.347E-02	1.240E-01	1.575E-01
5313500	I	.721	1.954	1.433	.588	3.037E-03	1.123E-02	1.427E-02	1.436E+07	1.818E-02	3.352E-02	1.240E-01	1.575E-01
5413500	XF	1.380	.857	1.076	1.430	5.812E-03	4.903E-03	1.072E-02	3.492E+07	6.153E-02	6.414E-02	5.411E-02	1.183E-01
5513600	CS	.046	.608	.370	.124	1.932E-04	3.496E-03	3.699E-03	3.017E+06	1.809E-01	2.132E-03	3.858E-02	4.071E-02
5613710	BA	0.000	.511	.275	.339	0.	2.940E-03	2.940E-03	8.265E+06	6.750E-05	0.	3.244E-02	3.244E-02
5614000	BA	3.652	2.070	2.739	4.183	1.538E-02	1.190E-02	2.728E-02	1.021E+08	6.025E+00	1.697E-01	1.313E-01	3.010E-01

5714000	LA	7.243	23.603	16.495	4.499	3.050E-02	1.397E-01	1.662E-01	1.098E+08	8.490E-01	3.366E-01	1.497E+00	1.834E+00
5814100	CE	2.054	.676	1.759	4.135	8.650E-03	3.888E-03	1.254E-02	1.010E+08	1.515E+01	9.545E-02	4.291E-02	1.384E-01
5814300	CE	3.274	1.593	7.351	2.504	1.379E-02	9.730E-03	2.352E-02	6.123E+07	3.883E-01	1.521E-01	1.074E-01	2.395E-01
5914300	PR	3.771	0.900	1.574	3.738	1.588E-02	0.	1.588E-02	9.127E+07	5.716E+00	1.752E-01	0.	1.752E-01
5814400	CE	.903	.230	.414	3.494	3.801E-03	1.323E-03	5.124E-03	8.530E+07	1.119E+02	4.195E-02	1.460E-02	5.655E-02
5914400	PR	13.741	.247	5.953	3.494	5.786E-02	1.421E-03	5.928E-02	8.530E+07	4.721E-03	6.385E-01	1.568E-02	6.542E-01
5914500	PR	.569	.008	.745	.259	2.394E-03	4.682E-05	2.441E-03	6.325E+06	7.269E-03	2.642E-02	5.167E-04	2.694E-02
6014700	ND	1.201	.432	.757	1.594	5.057E-03	2.484E-03	7.541E-03	3.896E+07	1.975E+00	5.581E-02	2.741E-02	8.322E-02
6114800	PM	1.189	.737	.929	.513	5.005E-03	4.239E-03	9.244E-03	1.252E+07	3.101E-01	5.523E-02	4.678E-02	1.020E-01
6114900	PM	1.539	.043	.675	1.313	6.483E-03	2.450E-04	6.727E-03	3.205E+07	3.270E-01	7.154E-02	2.703E-03	7.424E-02
6215300	SM	.786	.261	.493	1.094	3.310E-03	1.500E-03	4.810E-03	2.671E+07	2.397E-01	3.653E-02	1.655E-02	5.307E-02
6315600	EU	1.030	2.311	1.769	.749	4.337E-03	1.328E-02	1.762E-02	1.877E+07	1.316E+00	4.785E-02	1.466E-01	1.944E-01

TABLE B-XXXVIII

TMT-2 IF OPERATED 26K HRS AT 2772. MW CONT. C1NER-10(LASL) 8/79

35=TIME STEP
 1.80000E+05=TOTAL TIME SINCE LAST TIME AT POWER(S)
 9.36716E+07=TOTAL ELAPSED TIME(S)
 6.88811E+19=FISSIONS/S AT LAST TS AT POWER (22)
 2.77200E+09=POWER (WATTS) AT LAST TS AT POWER (2.77200E+03 MW)
 7.28678E+03=ACCUMULATED FISSIONS (FISSIONS PER BARN-CM)
 1.44045E+04=TOTAL FP IN SUM PER BARN-CM

7.24149E+19=TOTAL ACTIVITY (DPS/S)
 1.95716E+09=TOTAL CURIES
 3.55107E+00=TOTAL BETA DECAY POWER (MW)
 5.00204E+00=TOTAL GAMMA DECAY POWER (MW)
 8.55312E+00=TOTAL DECAY POWER (MW)
 3.21794E-01=TOTAL BETA MFV/F
 4.53279E-01=TOTAL GAMMA MFV/F
 7.75073E-01=TOTAL DECAY MFV/F

ID	SYM	PERCENT OF ALL FP				MEV/FISS			CURIES	DENSITY	DECAY POWER IN MW		
		BETA	GAMMA	TOTAL	CURIES	BETA	GAMMA	TOTAL			BETA	GAMMA	TOTAL
3808900	SR	4.936	0.000	2.049	2.596	1.588E-02	0.	1.588E-02	5.081E+07	1.219E+01	1.753E-01	0.	1.753E-01
3909000	Y	1.006	.000	.418	.311	3.238E-03	9.737E-07	3.239E-03	6.474E+06	7.972E-02	3.573E-02	1.074E-03	3.574E-02
3909100	Y	6.919	.022	2.895	3.495	2.227E-02	9.773E-05	2.236E-02	6.840E+07	1.849E+01	2.457E-01	1.079E-03	2.468E-01
3909300	Y	.583	.031	.251	.151	1.877E-03	1.420E-04	2.019E-03	2.950E+06	5.783E-03	2.072E-02	1.566E-03	2.228E-02
4009500	ZR	1.954	8.775	5.945	5.142	6.286E-03	3.979E-02	4.604E-02	1.006E+08	3.040E+01	6.937E-02	4.391E-01	5.085E-01
4109500	NB	.759	9.473	5.855	5.333	2.442E-03	4.294E-02	4.538E-02	1.044E+08	1.690E+01	2.695E-02	4.739E-01	5.008E-01
4009700	ZR	1.581	.285	.825	.484	5.087E-03	1.308E-03	6.395E-03	1.339E+07	4.324E-02	5.614E-02	1.443E-02	7.057E-02
4109700	NB	1.129	1.160	1.147	.739	3.634E-03	5.258E-03	8.893E-03	1.446E+07	3.408E-03	4.011E-02	5.803E-02	9.814E-02
4109710	NB	0.000	1.017	.495	.590	0.	4.610E-03	4.610E-03	1.156E+07	3.331E-05	0.	5.087E-02	5.087E-02
4209900	MD	4.387	1.506	2.732	3.490	1.412E-02	6.826E-03	2.094E-02	6.830E+07	8.665E-01	1.558E-01	7.533E-02	2.311E-01
4309910	TC	0.000	1.097	.641	3.312	0.	4.971E-03	4.971E-03	6.483E+07	7.499E-02	0.	5.485E-02	5.485E-02
4410300	RU	1.188	6.120	4.073	5.384	3.823E-03	2.774E-02	3.157E-02	1.054E+08	1.925E+01	4.219E-02	3.061E-01	3.483E-01
4510310	RH	0.000	.497	.291	5.390	0.	2.254E-03	2.254E-03	1.055E+08	1.892E-02	0.	2.488E-02	2.488E-02
4510500	RH	.797	.293	.912	1.602	2.564E-03	1.326E-03	3.890E-03	3.134E+07	2.138E-01	2.829E-02	1.464E-02	4.293E-02
4410600	RU	.071	0.000	.029	2.166	2.270E-04	0.	2.270E-04	4.239E+07	7.215E+01	2.505E-03	0.	2.505E-03
4510600	RH	10.230	1.002	4.813	2.156	3.292E-02	4.542E-03	3.746E-02	4.239E+07	6.766E-05	3.633E-01	5.012E-02	4.134E-01
4711000	AG	.803	.020	.345	.208	2.585E-03	9.112E-05	2.676E-03	4.078E+06	4.739E+00	2.852E-02	1.005E-03	2.953E-02

5213110	TE	.095	.542	.740	.159	3.041E-04	2.489E-03	2.793E-03	3.108E+06	1.792E-02	3.356E-03	2.747E-02	3.082E-02
5313100	I	1.689	2.516	2.172	2.796	5.434E-03	1.140E-02	1.694E-02	5.454E+07	2.022E+00	5.997E-02	1.258E-01	1.858E-01
5213200	TE	.582	1.850	1.323	2.949	1.874E-03	8.394E-03	1.026E-02	5.811E+07	8.709E-01	2.068E-02	9.252E-02	1.132E-01
5313200	I	5.243	15.974	11.440	3.059	1.687E-02	7.195E-02	8.882E-02	5.986E+07	2.628E-02	1.862E-01	7.940E-01	9.802E-01
5313300	I	1.710	1.743	1.729	1.255	5.503E-03	7.899E-03	1.340E-02	2.455E+07	9.815E-02	6.072E-02	6.717E-02	1.479E-01
5413300	XE	1.925	1.093	1.438	2.793	6.196E-03	4.953E-03	1.115E-02	1.132E+08	2.762E+00	6.837E-02	5.465E-02	1.230E-01
5513400	CS	.379	2.639	1.438	.717	1.220E-03	1.194E-02	1.316E-02	1.408E+07	4.885E+01	1.346E-02	1.318E-01	1.453E-01
5513600	CS	.056	.772	.445	.144	1.808E-04	3.271E-03	3.451E-03	2.822E+06	1.692E-01	1.995E-03	3.609E-02	3.909E-02
5613710	BA	0.000	.469	.379	.422	0.	2.939E-03	2.939E-03	8.264E+06	6.749E-05	0.	3.244E-02	3.244E-02
5614000	BA	4.466	2.453	3.299	4.877	1.437E-02	1.112E-02	2.549E-02	9.545E+07	5.631E+00	1.586E-01	1.227E-01	2.813E-01
5714000	LA	9.082	29.684	20.546	5.377	2.923E-02	1.300E-01	1.592E-01	1.052E+08	8.136E-01	3.225E-01	1.435E+00	1.757E+00
5814100	CF	2.618	.935	1.575	5.024	9.424E-03	3.787E-03	1.221E-02	9.832E+07	1.475E+01	9.296E-02	4.179E-02	1.347E-01
5814300	CE	2.281	1.143	1.416	1.555	7.341E-03	5.182E-03	1.252E-02	3.261E+07	2.068E-01	8.101E-02	5.718E-02	1.382E-01
5814300	PR	4.731	0.000	1.995	4.519	1.539E-02	0.	1.539E-02	8.842E+07	5.538E+00	1.698E-01	0.	1.698E-01
5814400	CE	1.178	.291	.659	4.345	1.790E-03	1.319E-03	5.107E-03	8.504E+07	1.115E+02	4.182E-02	1.455E-02	5.637E-02
5914400	PR	17.927	.313	7.626	4.345	5.769E-02	1.417E-03	5.910E-02	8.505E+07	4.707E-03	6.366E-01	1.563E-02	6.522E-01
6014700	ND	1.452	.506	.829	1.440	4.674E-03	2.296E-03	6.970E-03	3.600E+07	1.825E+00	5.158E-02	2.533E-02	7.691E-02
6114700	PM	.122	.000	.091	.592	3.924E-04	6.228E-07	3.930E-04	1.159E+07	5.123E+01	4.330E-03	6.873E-06	4.337E-03
6114800	PM	1.326	.797	1.017	.545	4.267E-03	3.614E-03	7.881E-03	1.067E+07	2.643E-01	4.709E-02	3.988E-02	8.697E-02
6114810	PM	.052	.505	.317	1.08	1.678E-04	2.288E-03	2.456E-03	2.120E+06	4.038E-01	1.852E-03	2.525E-02	2.711E-02
6114900	PM	1.342	.037	.597	1.107	4.382E-03	1.656E-04	4.548E-03	2.166E+07	2.211E-01	4.836E-02	1.827E-03	5.018E-02
6215300	SM	.659	.212	.328	.874	2.121E-03	9.607E-04	3.081E-03	1.711E+07	1.536E-01	2.340E-02	1.060E-02	3.400E-02
6315600	EU	1.274	2.769	2.148	.906	4.098E-03	1.255E-02	1.665E-02	1.773E+07	1.243E+00	4.522E-02	1.385E-01	1.837E-01

TABLE B-XXXXX

TMI-2 IF OPERATED 26K HRS AT 2772. MW CONT. CINER-10(LASL) 8/79

36=TIME STEP
 3.60000E+05=TOTAL TIME SINCE LAST TIME AT POWER(S)
 9.38516E+07=TOTAL ELAPSED TIME(S)
 6.88811E+19=FISSIONS/S AT LAST TS AT POWER (22)
 2.77200E+09=POWER (WATTS) AT LAST TS AT POWER (2.77200E+03 MW)
 7.28678E+03=ACCUMULATED FISSIONS (FISSIONS PER BARN-CM)
 1.44045E+04=TOTAL FP IN SUM PER BARN-CM

6.03494E+19=TOTAL ACTIVITY (DTS/S)
 1.63106E+09=TOTAL CURIES
 2.97911E+00=TOTAL BETA DECAY POWER (MW)
 4.10425E+00=TOTAL GAMMA DECAY POWER (MW)
 7.08336E+00=TOTAL DECAY POWER (MW)
 2.69963E-01=TOTAL BETA MFV/F
 3.71922E-01=TOTAL GAMMA MFV/F
 6.41885E-01=TOTAL DECAY MFV/F

ID	SYM	PERCENT OF		ALL FP		MEV/FISS			DECAY POWER IN MW				
		BETA	GAMMA	TOTAL	CURIES	BETA	GAMMA	TOTAL	BETA	GAMMA	TOTAL		
3808900	SR	5.723	0.000	2.407	3.030	1.545E-02	0.	1.545E-02	4.942E+07	1.185E+01	1.705E-01	0.	1.705E-01
3909000	Y	1.184	.000	.498	.392	3.197E-03	9.614E-07	3.197E-03	6.392E+06	7.871E-02	3.527E-02	1.061E-05	3.529E-02
3909100	Y	8.048	.026	3.400	4.022	2.173E-02	9.537E-03	2.142E-02	6.675E+07	1.804E+01	2.398E-01	1.052E-03	2.408E-01
4009500	ZR	2.278	10.444	7.022	4.035	6.149E-03	3.892E-02	4.507E-02	9.844E+07	2.974E+01	6.786E-02	4.295E-01	4.974E-01
4109500	NB	.903	11.524	7.057	6.398	2.438E-03	4.286E-02	4.530E-02	1.042E+08	1.687E+01	2.690E-02	4.730E-01	4.999E-01
4209900	MJ	3.093	1.086	1.970	2.477	8.351E-03	4.038E-03	1.239E-02	4.041E+07	5.126E-01	9.215E-02	4.456E-02	1.367E-01

4309910	TC	0.000	.791	.498	2.352	0.	2.942E-03	2.942E-03	3.837E+07	4.439E-02	0.	3.246E-02	3.246E-02
4410300	PU	1.365	7.192	4.742	6.230	3.686E-03	2.675E-02	3.044E-02	1.016E+08	1.856E+01	4.069E-02	2.952E-01	3.359E-01
4510310	RH	0.000	.584	.339	6.237	0.	2.174E-03	2.174E-03	1.017E+08	1.824E-02	0.	2.399E-02	2.399E-02
4510500	RH	.198	.134	.228	.724	9.660E-04	4.997E-04	1.466E-03	1.181E+07	8.057E-02	1.066E-02	5.514E-03	1.617E-02
4410600	RU	.084	0.000	.035	2.592	2.261E-04	0.	2.261E-04	4.223E+07	7.186E+01	2.496E-03	0.	2.496E-03
4510600	RH	12.147	1.216	5.813	2.599	3.279E-02	4.524E-03	3.732E-02	4.223E+07	6.740E-05	3.619E-01	4.992E-02	4.118E-01
4711000	AG	.252	.024	.414	.240	2.570E-03	9.059E-05	2.660E-03	4.034E+06	4.712E+00	2.836E-02	9.997E-04	2.936E-02
5313100	I	1.693	2.579	2.236	2.812	4.571E-03	9.591E-03	1.416E-02	4.587E+07	1.701E+00	5.044E-02	1.058E-01	1.563E-01
5213200	TE	.445	1.445	1.025	2.294	1.202E-03	5.376E-03	6.579E-03	3.726E+07	5.585E-01	1.326E-02	5.933E-02	7.259E-02
5313200	I	4.007	12.406	8.873	2.353	1.082E-02	4.614E-02	5.696E-02	3.839E+07	1.686E-02	1.194E-01	5.092E-01	6.285E-01
5413300	XE	1.817	1.034	1.378	5.495	4.905E-03	3.921E-03	8.826E-03	8.963E+07	2.187E+00	5.413E-02	4.327E-02	9.740E-02
5513400	CS	.451	3.205	2.047	.851	1.217E-03	1.192E-02	1.314E-02	1.405E+07	4.875E+01	1.343E-02	1.316E-01	1.450E-01
5513600	CS	.060	.787	.481	.155	1.618E-04	2.927E-03	3.089E-03	2.526E+06	1.514E-01	1.785E-03	3.230E-02	3.408E-02
5513700	CS	.303	0.000	.128	.536	8.184E-04	0.	8.184E-04	8.735E+06	4.429E+02	9.032E-03	0.	9.032E-03
5613710	BA	0.000	.790	.454	.507	0.	2.939E-03	2.939E-03	8.263E+06	6.748E-05	0.	3.243E-02	3.243E-02
5614000	BA	4.755	2.671	3.947	5.227	1.284E-02	9.932E-03	2.277E-02	8.526E+07	5.029E+00	1.416E-01	1.096E-01	2.513E-01
5714000	LA	9.893	31.947	22.672	5.896	2.671E-02	1.188E-01	1.455E-01	9.617E+07	7.435E-01	2.947E-01	1.311E+00	1.606E+00
5814100	CE	2.985	.974	1.820	5.756	8.058E-03	3.622E-03	1.168E-02	9.405E+07	1.411E+01	8.892E-02	3.997E-02	1.289E-01
5814300	CE	.951	.487	.693	.629	2.568E-03	1.813E-03	4.381E-03	1.141E+07	7.234E-02	2.834E-02	2.000E-02	4.835E-02
5914300	PR	5.254	0.000	2.210	4.998	1.418E-02	0.	1.418E-02	8.152E+07	5.106E+00	1.565E-01	0.	1.565E-01
5814400	CE	1.397	.353	.722	5.198	3.771E-03	1.312E-03	5.083E-03	8.461E+07	1.110E+02	4.161E-02	1.448E-02	5.609E-02
5914400	PR	21.260	.379	9.151	5.198	5.739E-02	1.409E-03	5.880E-02	8.461E+07	4.683E-03	6.334E-01	1.555E-02	6.489E-01
6014700	ND	1.518	.541	.932	1.936	4.099E-03	2.013E-03	6.111E-03	3.157E+07	1.600E+00	4.523E-02	2.221E-02	6.744E-02
6114700	PM	.146	.000	.051	.713	3.935E-04	6.246E-07	3.941E-04	1.163E+07	5.138E+01	4.342E-03	6.893E-06	4.349E-03
6114800	PM	1.212	.745	.942	.502	3.273E-03	2.772E-03	6.044E-03	8.185E+06	2.027E-01	3.611E-02	3.059E-02	6.670E-02
6114810	PM	.060	.594	.370	.126	1.621E-04	2.210E-03	2.372E-03	2.047E+06	3.900E-01	1.789E-03	2.439E-02	2.617E-02
6114900	PM	.845	.023	.359	.691	2.282E-03	8.621E-05	2.368E-03	1.128E+07	1.151E-01	2.518E-02	9.514E-04	2.613E-02
6315600	EU	1.381	3.062	2.359	.989	3.727E-03	1.142E-02	1.514E-02	1.613E+07	1.131E+00	4.113E-02	1.260E-01	1.671E-01

TABLE B-XL

TMT-2 IF OPERATED 26K HRS AT 2772. MW CONT. C1NER-10(LASL) 8/79

37=TIME STEP
7.20000E+05=TOTAL TIME SINCE LAST TIME AT POWER(S)
9.42116E+07=TOTAL ELAPSED TIME(S)
6.88811E+19=FISSIONS/S AT LAST TS AT POWER (22)
2.77200E+09=POWER (WATTS) AT LAST TS AT POWER (2.77200E+03 MW)
7.28678E+03=ACCUMULATED FISSIONS (FISSIONS PER BARN-CM)
1.44044E+04=TOTAL FP IN SUM PER BARN-CM

4.92032E+19=TOTAL ACTIVITY (DPS/S)
1.32982E+09=TOTAL CURIES
2.51011E+00=TOTAL BETA DECAY POWER (MW)
3.21344E+00=TOTAL GAMMA DECAY POWER (MW)
5.72355E+00=TOTAL DECAY POWER (MW)
2.27463E-01=TOTAL BETA MFV/F
2.91198E-01=TOTAL GAMMA MFV/F
5.18661E-01=TOTAL DECAY MFV/F

ID	SYM	PERCENT OF ALL FP				MEV/FISS			DECAY POWER IN MW				
		BETA	GAMMA	TOTAL	CURIES	BETA	GAMMA	TOTAL	CURIES	DENSITY	BETA	GAMMA	TOTAL
3808900	SR	6.425	0.000	2.818	3.915	1.462E-02	0.	1.462E-02	4.675E+07	1.121E+01	1.613E-01	0.	1.613E-01
3904000	Y	1.388	.000	.629	.475	3.158E-03	9.499E-07	3.159E-03	6.315E+06	7.777E-02	3.485E-02	1.048E-05	3.486E-02

3909100	Y	9.093	.031	4.075	4.779	2.068E-02	9.078E-05	2.077E-02	6.354E+07	1.717E+01	2.287E-01	1.002E-03	2.292E-01
4009500	ZR	2.587	17.797	8.715	7.083	5.884E-03	3.724E-02	4.313E-02	9.420E+07	2.846E+01	6.493E-02	4.110E-01	4.759E-01
4109500	NB	1.065	14.631	8.691	7.788	2.423E-03	4.260E-02	4.303E-02	1.036E+08	1.676E+01	2.674E-02	4.701E-01	4.969E-01
4209900	MO	1.285	.485	.874	1.063	2.922E-03	1.413E-03	4.336E-03	1.414E+07	1.794E-01	3.225E-02	1.560E-02	4.785E-02
4309910	TC	0.000	.394	.179	1.010	0.	1.030E-03	1.030E-03	1.343E+07	1.553E-02	0.	1.136E-02	1.136E-02
4410300	RU	1.507	8.547	5.455	7.104	3.427E-03	2.487E-02	2.829E-02	9.447E+07	1.725E+01	3.782E-02	2.744E-01	3.122E-01
4510310	RH	0.000	.694	.390	7.111	0.	2.021E-03	2.021E-03	9.457E+07	1.696E-02	0.	2.230E-02	2.230E-02
4410600	RU	.099	0.077	.043	3.151	2.244E-04	0.	2.244E-04	4.190E+07	7.130E+01	2.476E-03	0.	2.476E-03
4510600	RH	14.304	1.541	7.138	3.151	3.254E-02	4.489E-03	3.702E-02	4.190E+07	6.687E-05	3.590E-01	4.953E-02	4.086E-01
4711000	AG	1.117	.031	.577	.301	2.540E-03	8.956E-05	2.630E-03	4.008E+06	4.658E+00	2.803E-02	9.883E-04	2.902E-02
5313100	I	1.408	2.708	1.913	2.417	3.202E-03	6.720E-03	9.922E-03	3.214E+07	1.192E+00	3.534E-02	7.416E-02	1.095E-01
5213200	TE	.717	.757	.522	1.152	4.942E-04	2.211E-03	2.705E-03	1.532E+07	2.297E-01	5.454E-03	2.440E-02	2.985E-02
5313200	I	1.956	8.515	4.516	1.187	4.449E-03	1.897E-02	2.347E-02	1.578E+07	6.931E-03	4.909E-02	2.094E-01	2.585E-01
5413300	XE	1.274	.796	1.076	3.983	2.899E-03	2.317E-03	5.216E-03	5.297E+07	1.292E+00	3.199E-02	2.557E-02	5.756E-02
5513400	CS	.533	4.078	2.573	1.052	1.213E-03	1.188E-02	1.309E-02	1.400E+07	4.857E+01	1.338E-02	1.311E-01	1.444E-01
5513600	CS	.057	.805	.477	.152	1.295E-04	2.344E-03	2.473E-03	2.023E+06	1.213E-01	1.429E-03	2.586E-02	2.729E-02
5513700	CS	.360	0.000	.158	.657	8.182E-04	0.	8.182E-04	8.732E+06	4.428E+02	9.029E-03	0.	9.029E-03
5613710	BA	0.000	1.009	.567	.621	0.	2.938E-03	2.938E-03	8.261E+06	6.747E-05	0.	3.242E-02	3.242E-02
5614000	BA	4.502	2.771	3.573	5.116	1.024E-02	7.925E-03	1.817E-02	6.803E+07	4.013E+00	1.130E-01	6.745E-02	2.005E-01
5714000	LA	9.516	33.067	22.779	5.861	2.165E-02	9.629E-02	1.179E-01	7.794E+07	6.026E-01	2.389E-01	1.063E+00	1.301E+00
5814100	CE	3.242	1.138	2.061	6.472	7.373E-03	3.315E-03	1.069E-02	8.606E+07	1.291E+01	8.137E-02	3.658E-02	1.179E-01
5914300	PR	5.109	0.000	2.740	5.077	1.162E-02	0.	1.162E-02	6.679E+07	4.183E+00	1.282E-01	0.	1.282E-01
5814400	CE	1.641	.446	.970	6.298	3.732E-03	1.299E-03	5.031E-03	8.376E+07	1.099E+02	4.119E-02	1.433E-02	5.552E-02
5914400	PR	24.977	.479	11.773	8.239	5.681E-02	1.395E-03	5.821E-02	8.376E+07	4.636E-03	6.270E-01	1.540E-02	6.424E-01
6014700	ND	1.385	.531	.906	1.825	3.151E-03	1.548E-03	4.699E-03	2.427E+07	1.230E+00	3.478E-02	1.708E-02	5.186E-02
6114700	PM	.174	.000	.076	.878	3.952E-04	6.273E-07	3.958E-04	1.168E+07	5.160E+01	4.361E-03	6.922E-06	4.368E-03
6114800	PM	.849	.567	.688	.363	1.931E-03	1.635E-03	3.566E-03	4.829E+06	1.196E-01	2.131E-02	1.805E-02	3.935E-02
6114810	PM	.066	.708	.476	.144	1.511E-04	2.061E-03	2.212E-03	1.909E+06	3.636E-01	1.668E-03	2.274E-02	2.441E-02
6315600	EU	1.355	7.747	7.414	1.073	3.082E-03	9.440E-03	1.252E-02	1.334E+07	9.350E-01	3.401E-02	1.042E-01	1.382E-01

TABLE B-XLI

TMI-2 IF OPERATED 26K HRS AT 2772. MW CONT. CINDER-10(LASL) 8/79

38=TIME STEP

1.80000E+06=TOTAL TIME SINCE LAST TIME AT POWER(S)
 9.52916E+07=TOTAL ELAPSED TIME(S)
 6.98811E+19=FISSIONS/S AT LAST TS AT POWER (22)
 2.77200E+09=POWER (WATTS) AT LAST TS AT POWER (2.77200E+03 MW)
 7.28678E+03=ACCUMULATED FISSIONS (FISSIONS PER BARN-CM)
 1.44044E+04=TOTAL FP IN SJM PER BARN-CM

3.59195E+19=TOTAL ACTIVITY (DTS/S)
 9.70797E+08=TOTAL CURTES
 1.94141E+00=TOTAL BETA DECAY POWER (MW)
 2.08489E+00=TOTAL GAMMA DECAY POWER (MW)
 4.02629E+00=TOTAL DECAY POWER (MW)
 1.75928E-01=TOTAL BETA MFV/F
 1.88930E-01=TOTAL GAMMA MFV/F
 3.64858E-01=TOTAL DECAY MFV/F

ID ZZAAAS	SYM	PERCENT OF ALL FP				MEV/FISS			CURIES	DENSITY	---DECAY POWER IN MW---		
		BETA	GAMMA	TOTAL	CURIES	BETA	GAMMA	TOTAL			BETA	GAMMA	TOTAL
3808900	SR	7.032	0.000	3.371	4.074	1.237E-02	0.	1.237E-02	3.957E+07	9.491E+00	1.365E-01	0.	1.365E-01
3809000	SR	.379	0.000	.197	.445	6.669E-04	0.	6.669E-04	6.270E+06	2.968E+02	7.359E-03	0.	7.359E-03
3909000	Y	1.783	.000	.950	.644	3.137E-03	9.435E-07	3.138E-03	6.273E+06	7.725E-02	3.462E-02	1.041E-05	3.463E-02
3909100	Y	10.140	.041	4.911	5.645	1.784E-02	7.831E-05	1.792E-02	5.480E+07	1.481E+01	1.969E-01	8.641E-04	1.977E-01
4009500	ZR	2.930	17.771	10.356	9.571	5.155E-03	3.263E-02	3.778E-02	8.252E+07	2.493E+01	5.689E-02	3.601E-01	4.170E-01
4109500	NB	1.337	21.811	11.936	10.318	2.344E-03	4.121E-02	4.355E-02	1.002E+08	1.621E+01	2.586E-02	4.547E-01	4.806E-01
4410300	RU	1.565	10.576	6.731	7.819	2.754E-03	1.998E-02	2.273E-02	7.591E+07	1.386E+01	3.039E-02	2.205E-01	2.509E-01
4510310	RH	0.000	.959	.445	7.827	0.	1.624E-03	1.624E-03	7.598E+07	1.363E-02	0.	1.792E-02	1.792E-02
4410600	RU	.125	0.000	.040	4.715	7.192E-04	0.	2.192E-04	4.093E+07	6.965E+01	2.419E-03	0.	2.419E-03
4510600	RH	18.065	2.371	9.912	4.216	3.178E-02	4.384E-03	3.617E-02	4.093E+07	6.532E-05	3.507E-01	4.838E-02	3.991E-01
4711000	AG	1.395	.044	.696	.399	2.455E-03	8.654E-05	2.541E-03	3.873E+06	4.501E+00	2.709E-02	9.549E-04	2.804E-02
5313100	I	.620	1.212	.926	1.129	1.091E-03	2.289E-03	3.380E-03	1.095E+07	4.060E-01	1.204E-02	2.526E-02	3.730E-02
5313200	I	.176	.598	.446	.113	3.093E-04	1.319E-03	1.629E-03	1.098E+06	4.819E-04	3.413E-03	1.456E-02	1.797E-02
5413300	XE	.323	.241	.291	1.071	5.688E-04	4.547E-04	1.024E-03	1.039E+07	2.536E-01	6.277E-03	5.018E-03	1.129E-02
5513400	CS	.681	6.714	3.546	1.425	1.199E-03	1.174E-02	1.294E-02	1.383E+07	4.801E+01	1.323E-02	1.295E-01	1.428E-01
5513600	CS	.038	.637	.348	.107	6.652E-05	1.204E-03	1.270E-03	1.039E+06	6.227E-02	7.340E-04	1.328E-02	1.402E-02
5513700	CS	.465	0.000	.224	.899	8.176E-04	0.	8.176E-04	8.725E+06	4.424E+02	9.022E-03	0.	9.022E-03
5613710	BA	0.000	1.554	.875	.950	0.	2.936E-03	2.936E-03	8.254E+06	6.741E-05	0.	3.240E-02	3.240E-02
5614000	BA	2.957	2.131	2.529	3.559	5.202E-03	4.025E-03	9.227E-03	3.455E+07	2.038E+00	5.740E-02	4.442E-02	1.018E-01
5714000	LA	6.277	26.007	16.491	4.096	1.104E-02	4.913E-02	6.017E-02	3.976E+07	3.074E-01	1.219E-01	5.421E-01	6.640E-01
5814100	CE	3.211	1.344	2.244	6.792	5.649E-03	2.540E-03	8.189E-03	6.594E+07	9.893E+00	6.234E-02	2.803E-02	9.037E-02
5914300	PR	3.498	0.000	1.697	3.643	6.154E-03	0.	6.154E-03	3.537E+07	2.215E+00	6.791E-02	0.	6.791E-02
5814400	CE	2.058	.647	1.338	8.349	3.620E-03	1.260E-03	4.880E-03	8.124E+07	1.066E+02	3.995E-02	1.390E-02	5.386E-02
5914400	PR	31.325	.716	15.475	8.349	5.511E-02	1.353E-03	5.646E-02	8.125E+07	4.496E-03	6.081E-01	1.493E-02	6.231E-01
6014700	ND	.814	.372	.585	1.137	1.433E-03	7.036E-04	2.136E-03	1.103E+07	5.593E-01	1.581E-02	7.764E-03	2.357E-02
6114700	PM	.226	.000	.179	1.709	3.968E-04	6.298E-07	3.974E-04	1.173E+07	5.181E+01	4.379E-03	6.931E-06	4.386E-03
6114810	PM	.070	.884	.491	.159	1.225E-04	1.671E-03	1.793E-03	1.548E+06	2.948E-01	1.352E-03	1.844E-02	1.979E-02
6315600	EU	.991	2.826	1.941	.777	1.743E-03	5.339E-03	7.081E-03	7.542E+06	5.287E-01	1.923E-02	5.891E-02	7.815E-02

TABLE B-XLII

TIME-? IF OPERATED 26K HRS AT 2772. MW CONT. CENER-10(LASL) 8/79

39=TIME STEP
3.60000E+06=TOTAL TIME SINCE LAST TIME AT POWER(S)
9.70916E+07=TOTAL ELAPSED TIME(S)
6.88811E+19=FISSIONS/S AT LAST TS AT POWER (22)
2.77200E+09=POWER (WATTS) AT LAST TS AT POWER (2.77200E+03 MW)
7.28678E+03=ACCUMULATED FISSIONS (FISSIONS PER BARN-CM)
1.44042E+04=TOTAL FP IN SUM PER BARN-CM

2.69032E+19=TOTAL ACTIVITY (DIS/S)
7.27113E+09=TOTAL CURIFS
1.54835E+00=TOTAL BETA DECAY POWER (MW)
1.37510E+00=TOTAL GAMMA DECAY POWER (MW)
2.92345E+00=TOTAL DECAY POWER (MW)
1.40310E-01=TOTAL BETA MEV/F
1.24610E-01=TOTAL GAMMA MEV/F
2.64919E-01=TOTAL DECAY MEV/F

ID ZZAAAS	SYM	-----PERCENT OF ALL FP-----				-----MEV/FISS-----				---DECAY POWER IN MW---			
		BETA	GAMMA	TOTAL	CURIES	BETA	GAMMA	TOTAL	CURIES	DENSITY	BETA	GAMMA	TOTAL
3808900	SR	6.680	0.000	3.538	4.123	9.372E-03	0.	9.372E-03	2.998E+07	7.190E+00	1.034E-01	0.	1.034E-01
3809000	SR	.475	0.000	.251	.951	6.659E-04	0.	6.659E-04	6.261E+06	2.964E+02	7.349E-03	0.	7.349E-03
3909000	Y	2.232	.001	1.193	.951	3.132E-03	9.420E-07	3.133E-03	6.263E+06	7.712E-02	3.456E-02	1.040E-05	3.457E-02
3909100	Y	9.938	.049	5.285	5.921	1.394E-02	6.120E-05	1.400E-02	4.284E+07	1.158E+01	1.539E-01	6.754E-04	1.549E-01
4009500	ZR	2.947	21.005	11.441	9.124	4.135E-03	2.617E-02	3.031E-02	6.620E+07	2.000E+01	4.563E-02	2.888E-01	3.345E-01
4109500	NR	1.521	30.104	14.945	12.541	2.134E-03	3.751E-02	3.965E-02	9.119E+07	1.476E+01	2.355E-02	4.140E-01	4.375E-01
4410300	RU	1.363	11.135	5.959	7.250	1.912E-03	1.388E-02	1.579E-02	5.271E+07	9.627E+00	2.110E-02	1.531E-01	1.742E-01
4510310	RH	0.000	.905	.426	7.257	0.	1.127E-03	1.127E-03	5.277E+07	9.464E-03	0.	1.244E-02	1.244E-02
4410600	RU	.150	0.000	.090	5.412	2.108E-04	0.	2.108E-04	3.935E+07	6.698E+01	2.326E-03	0.	2.326E-03
4510600	RH	21.781	3.393	13.127	5.412	3.056E-02	4.216E-03	3.478E-02	3.935E+07	6.281E-05	3.372E-01	4.653E-02	3.838E-01
4711000	AG	1.652	.066	.906	.903	2.318E-03	8.172E-05	2.400E-03	3.657E+06	4.250E+00	2.558E-02	9.018E-04	2.648E-02
5513400	CS	.838	9.242	4.791	1.867	1.176E-03	1.152E-02	1.269E-02	1.357E+07	4.710E+01	1.298E-02	1.271E-01	1.401E-01
5513700	CS	.582	0.000	.379	1.198	8.165E-04	0.	8.165E-04	8.714E+06	4.418E+02	9.010E-03	0.	9.010E-03
5613710	BA	0.000	2.353	1.107	1.134	0.	2.932E-03	2.932E-03	8.243E+06	6.732E-05	0.	3.236E-02	3.236E-02
5614000	BA	1.199	1.049	1.126	1.937	1.682E-03	1.302E-03	2.984E-03	1.117E+07	6.591E-01	1.856E-02	1.436E-02	3.292E-02
5714000	LA	2.545	12.749	7.344	1.758	3.571E-03	1.589E-02	1.946E-02	1.286E+07	9.941E-02	3.941E-02	1.753E-01	2.147E-01
5814100	CE	2.583	1.307	1.993	5.818	3.624E-03	1.629E-03	5.253E-03	4.230E+07	6.346E+00	3.999E-02	1.798E-02	5.797E-02
5914300	PR	1.514	0.000	.802	1.690	2.125E-03	0.	2.125E-03	1.221E+07	7.648E-01	2.345E-02	0.	2.345E-02
5814400	CE	2.453	.961	1.751	10.620	3.441E-03	1.198E-03	4.639E-03	7.722E+07	1.013E+02	3.797E-02	1.322E-02	5.119E-02
5914400	PR	37.333	1.032	20.258	10.521	5.238E-02	1.286E-03	5.367E-02	7.722E+07	4.274E-03	5.780E-01	1.420E-02	5.922E-01
6114700	PM	.281	.001	.149	1.601	3.940E-04	6.254E-07	3.946E-04	1.164E+07	5.145E+01	4.348E-03	6.902E-06	4.355E-03
6114810	PM	.062	.945	.477	.150	8.638E-05	1.178E-03	1.264E-03	1.091E+06	2.078E-01	9.532E-04	1.300E-02	1.395E-02
6315400	EU	.092	.524	.225	.134	1.289E-04	6.524E-04	7.814E-04	9.717E+05	1.407E+01	1.423E-03	7.200E-03	8.622E-03
6315600	EU	.480	1.657	1.034	.401	6.740E-04	2.065E-03	2.739E-03	2.917E+06	2.045E-01	7.438E-03	2.278E-02	3.022E-02

TABLE B-XLIII

TIME, UNIT 2, 22-STEP POWER HISTORY, FULL CORE CALC., CINDER-10(LASL) 7/79

40=TIME STEP
 7.20000E+06=TOTAL TIME SINCE LAST TIME AT POWER(S)
 1.00692E+08=TOTAL ELAPSED TIME(S)
 6.88811E+19=FISSIONS/S AT LAST TS AT POWER (22)
 2.77200E+09=POWER (WATTS) AT LAST TS AT POWER (2.77200E+03 MW)
 7.28678E+03=ACCUMULATED FISSIONS (FISSIONS PER BARN-XLIICH)
 1.44040E+04=TOTAL FP IN SIM PER BARN-CM

1.87185E+19=TOTAL ACTIVITY (DIS/S)
 5.05906E+09=TOTAL CURIES
 1.20708E+00=TOTAL BETA DECAY POWER (MW)
 8.54116E-01=TOTAL GAMMA DECAY POWER (MW)
 2.06120E+00=TOTAL DECAY POWER (MW)
 1.09384E-01=TOTAL BETA MEV/F
 7.73990E-02=TOTAL GAMMA MEV/F
 1.86783E-01=TOTAL DECAY MEV/F

ID ZZAAAS	SYM	-----PERCENT OF ALL FP-----				-----MEV/FISS-----				---DECAY POWER IN MW---			
		BETA	GAMMA	TOTAL	CURIES	BETA	GAMMA	TOTAL	CURIES	DENSITY	BETA	GAMMA	TOTAL
3808900	SR	4.917	0.000	2.879	3.420	5.378E-03	0.	5.378E-03	1.720E+07	4.126E+00	5.935E-02	0.	5.935E-02
3809000	SR	.607	0.000	.396	1.234	6.641E-04	0.	6.641E-04	6.244E+06	2.956E+02	7.328E-03	0.	7.328E-03
3909000	Y	2.955	.001	1.673	1.235	3.123E-03	9.393E-07	3.124E-03	6.245E+06	7.691E-02	3.447E-02	1.037E-05	3.448E-02
3909100	Y	7.787	.049	4.590	5.172	8.518E-03	3.739E-05	8.555E-03	2.617E+07	7.072E+00	9.400E-02	4.126E-04	9.441E-02
4009500	ZR	2.432	21.759	10.441	8.419	2.661E-03	1.684E-02	1.950E-02	4.259E+07	1.287E+01	2.936E-02	1.858E-01	2.152E-01

4109500	NB	1.490	36.779	16.177	13.679	1.619E-03	2.847E-02	3.009E-02	6.920E+07	1.120E+01	1.787E-02	3.141E-01	3.320E-01
4410300	RU	.843	9.649	4.076	5.025	7.221E-04	6.691E-03	7.613E-03	2.542E+07	4.643E+00	1.018E-02	7.384E-02	8.401E-02
4510310	RH	0.000	.702	.271	5.030	0.	5.437E-04	5.437E-04	2.545E+07	4.564E-03	0.	6.000E-03	6.000E-03
4410600	RU	.178	0.000	.174	7.193	1.949E-04	0.	1.949E-04	3.639E+07	6.193E+01	2.151E-03	0.	2.151E-03
4510600	RH	25.836	5.077	17.217	7.193	2.826E-02	3.899E-03	3.216E-02	3.639E+07	5.808E-05	3.119E-01	4.302E-02	3.549E-01
4711000	AG	1.890	.094	1.146	.645	2.067E-03	7.287E-05	2.140E-03	3.261E+06	3.790E+00	2.281E-02	8.041E-04	2.361E-02
5513400	CS	1.035	14.317	6.539	2.587	1.132E-03	1.108E-02	1.221E-02	1.306E+07	4.532E+01	1.249E-02	1.223E-01	1.348E-01
5513700	CS	.744	0.000	.436	1.719	8.144E-04	0.	8.144E-04	8.691E+06	4.407E+02	8.987E-03	0.	8.987E-03
5613710	BA	0.000	3.778	1.556	1.625	0.	2.924E-03	2.924E-03	8.222E+06	6.715E-05	0.	3.227E-02	3.227E-02
5714000	LA	.341	2.146	1.089	.754	3.734E-04	1.661E-03	2.034E-03	1.344E+06	1.039E-02	4.120E-03	1.833E-02	2.245E-02
5814100	CE	1.364	.866	1.147	3.441	1.491E-03	6.705E-04	2.162E-03	1.741E+07	2.612E+00	1.646E-02	7.399E-03	2.386E-02
5814400	CE	2.842	1.398	2.264	13.790	3.109E-03	1.082E-03	4.191E-03	6.976E+07	9.151E+01	3.431E-02	1.194E-02	4.625E-02
5914400	PR	43.263	1.901	25.959	13.790	4.732E-02	1.162E-03	4.849E-02	6.977E+07	3.861E-03	5.222E-01	1.282E-02	5.350E-01
6114700	PM	.350	.001	.206	2.239	3.834E-04	6.085E-07	3.840E-04	1.133E+07	5.006E+01	4.231E-03	6.715E-06	4.237E-03
6114810	PM	.039	.754	.336	.107	4.292E-05	5.852E-04	6.281E-04	5.422E+05	1.033E-01	4.737E-04	6.458E-03	6.932E-03
6315400	EU	.117	.835	.414	.190	1.277E-04	6.465E-04	7.742E-04	9.628E+05	1.394E+01	1.410E-03	7.134E-03	8.543E-03

TABLE B-XLIV

TMT-2 TF OPERATED 26K HRS AT 2772. MW CONT. CINER-10(LASL) 8/79

- 41=TIME STEP
- 1.80000E+07=TOTAL TIME SINCE LAST TIME AT POWER(S)
- 1.11492E+08=TOTAL ELAPSED TIME(S)
- 6.88811E+19=FISSIONS/S AT LAST TS AT POWER (22)
- 2.77200E+09=POWER (WATTS) AT LAST TS AT POWER (2.77200E+03 MW)
- 7.28678E+03=ACCUMULATED FISSIONS (FISSIONS PER BARN-CM)
- 1.44033E+04=TOTAL FP IN SUM PER BARN-CM

- 9.94017E+18=TOTAL ACTIVITY (DIS/S)
- 2.68693E+08=TOTAL CURIES
- 7.92775E-01=TOTAL BETA DECAY POWER (MW)
- 3.66300E-01=TOTAL GAMMA DECAY POWER (MW)
- 1.15908E+00=TOTAL DECAY POWER (MW)
- 7.18403E-02=TOTAL BETA MEV/F
- 3.31937E-02=TOTAL GAMMA MEV/F
- 1.05034E-01=TOTAL DECAY MEV/F

ID ZZAAAS	SYM	-----PERCENT OF ALL FP-----			-----MEV/FISS-----			---DECAY POWER IN MW---					
		BETA	GAMMA	TOTAL	CURIES	BETA	GAMMA	TOTAL	CURIES	DENSITY	BETA	GAMMA	TOTAL
3808900	SR	1.415	0.000	.969	1.710	1.016E-03	0.	1.016E-03	3.251E+06	7.796E-01	1.121E-02	0.	1.121E-02
3809000	SR	.917	0.000	.427	2.305	6.585E-04	0.	6.585E-04	6.191E+06	2.931E+02	7.267E-03	0.	7.267E-03
3909000	Y	4.311	.003	2.950	2.325	3.097E-03	9.314E-07	3.098E-03	6.193E+06	7.626E-02	3.418E-02	1.028E-05	3.419E-02
3909100	Y	2.703	.026	1.857	2.271	1.942E-03	8.524E-06	1.950E-03	5.966E+06	1.612E+00	2.143E-02	9.406E-05	2.152E-02
4009500	ZR	.987	13.516	4.946	4.223	7.088E-04	4.484E-03	5.195E-03	1.135E+07	3.428E+00	7.821E-03	4.951E-02	5.733E-02
4109500	NB	.734	27.939	9.332	9.391	5.275E-04	9.274E-03	9.802E-03	2.254E+07	3.649E+00	5.821E-03	1.023E-01	1.082E-01
4410300	RU	.144	2.261	.813	1.061	1.034E-04	7.504E-04	8.538E-04	2.851E+06	5.206E-01	1.141E-03	8.280E-03	9.422E-03
4510310	RH	0.000	.194	.059	1.062	0.	6.097E-05	6.097E-05	2.854E+06	5.118E-04	0.	6.729E-04	6.729E-04
4410600	RU	.215	0.000	.147	10.711	1.541E-04	0.	1.541E-04	2.878E+07	4.897E+01	1.701E-03	0.	1.701E-03
4510600	RH	31.105	9.297	24.210	10.711	2.235E-02	3.083E-03	2.543E-02	2.878E+07	4.593E-05	2.466E-01	3.402E-02	2.806E-01
4711000	AG	2.040	.156	1.445	.841	1.466E-03	5.167E-05	1.517E-03	2.312E+06	2.687E+00	1.617E-02	5.702E-04	1.674E-02
5513400	CS	1.404	29.757	10.354	4.333	1.009E-03	9.877E-03	1.059E-02	1.164E+07	4.039E+01	1.113E-02	1.090E-01	1.201E-01
5513700	CS	1.125	0.000	.749	3.210	8.080E-04	0.	8.080E-04	8.623E+06	4.372E+02	8.916E-03	0.	8.916E-03
5613710	BA	0.000	9.741	2.742	3.036	0.	2.901E-03	2.901E-03	8.197E+06	6.662E-05	0.	3.202E-02	3.202E-02
5814400	CE	3.191	2.403	2.942	19.148	2.292E-03	7.978E-04	3.090E-03	5.144E+07	6.747E+01	2.530E-02	8.803E-03	3.410E-02

5914400 PR 48.573 2.582 34.038 19.149 3.489E-02 8.569E-04 3.575E-02 9.144E+07 2.847E-03 3.851E-01 9.456E-03 3.945E-01
 6114700 PM .488 .002 .334 3.883 3.503E-04 5.560E-07 3.509E-04 1.035E+07 4.574E+01 3.866E-03 6.136E-06 3.872E-03
 6315400 EU .173 1.895 .717 .349 1.243E-04 6.289E-04 7.531E-04 9.366E+05 1.356E+01 1.371E-03 6.940E-03 8.311E-03

TABLE B-XLV

TMT-2 IF OPERATED 26K HRS AT 2772. MW CONT. CINDER-10(LASL) 8/79

42=TIME STFP
 3.15360E+07=TOTAL TIME SINCE LAST TIME AT POWER(S)
 1.25028E+08=TOTAL ELAPSED TIME(S)
 6.88811E+19=FISSIONS/S AT LAST TS AT POWER (22)
 2.77200E+09=POWER (WATTS) AT LAST TS AT POWER (2.77200E+03 MW)
 7.28678E+03=ACCUMULATED FISSIONS (FISSIONS PER BARN-CM)
 1.44026E+04=TOTAL FP IN SIM PER BARN-CM

6.47132E+18=TOTAL ACTIVITY (DIS/S)
 1.74901E+08=TOTAL CURIFS
 5.49209E-01=TOTAL BETA DECAY POWER (MW)
 2.04227E-01=TOTAL GAMMA DECAY POWER (MW)
 7.53436E-01=TOTAL DECAY POWER (MW)
 4.97686E-02=TOTAL BETA MEV/F
 1.85068E-02=TOTAL GAMMA MEV/F
 6.82754E-02=TOTAL DECAY MEV/F

ID ZZAAAS	SYM	-----PERCENT OF		ALL FP-----		-----MEV/FISS-----			CURIES	DENSITY	---DECAY POWER IN MW---		
		BETA	GAMMA	TOTAL	CURIES	BETA	GAMMA	TOTAL			BETA	GAMMA	TOTAL
3809000	SR	1.309	0.000	.954	3.503	6.516E-04	0.	6.516E-04	6.126E+06	2.900E+02	7.190E-03	0.	7.190E-03
3909000	Y	6.157	.005	4.490	3.504	3.064E-03	9.216E-07	3.065E-03	6.128E+06	7.546E-02	3.382E-02	1.017E-05	3.383E-02
3909100	Y	.612	.007	.444	.534	3.044E-04	1.336E-06	3.057E-04	9.351E+05	2.527E-01	3.359E-03	1.474E-05	3.374E-03
4009500	ZR	.271	4.619	1.450	1.236	1.351E-04	8.548E-04	9.899E-04	2.162E+06	6.531E-01	1.490E-03	9.433E-03	1.092E-02
4109500	NB	.215	10.167	2.913	2.615	1.070E-04	1.882E-03	1.989E-03	4.574E+06	7.404E-01	1.181E-03	2.076E-02	2.194E-02
4410600	RU	.231	0.000	.168	12.258	1.148E-04	0.	1.148E-04	2.144E+07	3.649E+01	1.267E-03	0.	1.267E-03
4510600	RH	33.453	12.411	27.750	12.258	1.665E-02	2.297E-03	1.895E-02	2.144E+07	3.422E-05	1.837E-01	2.535E-02	2.091E-01
4711000	AG	1.914	.181	1.444	.959	9.525E-04	3.358E-05	9.861E-04	1.503E+06	1.746E+00	1.051E-02	3.706E-04	1.088E-02
5112500	SB	.057	.798	.258	.349	2.838E-05	1.477E-04	1.761E-04	6.083E+05	2.797E+00	3.132E-04	1.630E-03	1.943E-03
5513400	CS	1.754	46.199	13.831	5.761	8.730E-04	8.550E-03	9.423E-03	1.008E+07	3.497E+01	9.634E-03	9.435E-02	1.040E-01
5513700	CS	1.408	0.000	1.172	4.882	8.000E-04	0.	8.000E-04	8.538E+06	4.329E+02	8.829E-03	0.	8.829E-03
5613710	BA	0.000	15.523	4.208	4.618	0.	2.873E-03	2.873E-03	8.077E+06	6.597E-05	0.	3.170E-02	3.170E-02
5814400	CE	3.144	2.942	3.089	20.077	1.565E-03	5.446E-04	2.109E-03	3.512E+07	4.606E+01	1.727E-02	6.009E-03	2.328E-02
5914400	PR	47.860	3.161	35.744	20.077	2.382E-02	5.849E-04	2.440E-02	3.512E+07	1.943E-03	2.629E-01	6.455E-03	2.693E-01
6114700	PM	.628	.003	.459	5.284	3.128E-04	4.964E-07	3.133E-04	9.242E+06	4.084E+01	3.451E-03	5.478E-06	3.457E-03
6315400	EU	.241	3.282	1.056	.517	1.200E-04	6.075E-04	7.275E-04	9.047E+05	1.310E+01	1.325E-03	6.704E-03	8.028E-03

TABLE B-XLVI

TMI-2 IF OPERATED 26K HRS AT 2772. MW CONT. CINER-10(LASL) 8/79

43=TIME STEP

3.60000E+07=TOTAL TIME SINCE LAST TIME AT POWER(S)
 1.29492E+08=TOTAL ELAPSED TIME(S)
 6.88811E+19=FISSIONS/S AT LAST TS AT POWER, (22)
 2.77200E+09=POWER (WATTS) AT LAST TS AT POWER (2.77200E+03 MW)
 7.28678E+03=ACCUMULATED FISSIONS (FISSIONS PER BARN-CM)
 1.44023E+04=TOTAL FP IN SIM PER BARN-CM

5.83253E+18=TOTAL ACTIVITY (DIS/S)
 1.57636E+08=TOTAL CURIES
 4.93278E-01=TOTAL BETA DECAY POWER (MW)
 1.82615E-01=TOTAL GAMMA DECAY POWER (MW)
 6.75893E-01=TOTAL DECAY POWER (MW)
 4.47003E-02=TOTAL BETA MEV/F
 1.65483E-02=TOTAL GAMMA MEV/F
 6.12486E-02=TOTAL DECAY MEV/F

ID ZZAAAS	SYM	-----PERCENT OF ALL FP-----			-----MEV/FISS-----			---DECAY POWER IN MW---					
		BETA	GAMMA	TOTAL	CURIES	BETA	GAMMA	TOTAL	CURIES	DENSITY	BETA	GAMMA	TOTAL
3809000	SR	1.453	0.000	1.050	3.873	6.493E-04	0.	6.493E-04	6.105E+06	2.890E+02	7.165E-03	0.	7.165E-03
3909000	Y	6.832	.004	4.947	3.874	3.054E-03	9.184E-07	3.055E-03	6.106E+06	7.519E+02	3.370E-02	1.014E-05	3.371E-02
4009500	ZR	.175	2.990	.933	.794	7.817E-05	4.948E-04	5.730E-04	1.251E+06	3.780E+01	8.626E-04	5.460E-03	6.323E-03
4109500	NB	.140	6.629	1.873	1.692	6.239E-05	1.097E-03	1.159E-03	2.666E+06	4.316E+01	6.885E-04	1.210E-02	1.279E-02
4410600	RU	.233	0.000	.170	12.343	1.042E-04	0.	1.042E-04	1.946E+07	3.311E+01	1.150E-03	0.	1.150E-03
4510600	RH	33.802	12.594	28.072	12.343	1.511E-02	2.084E-03	1.719E-02	1.946E+07	3.105E+05	1.667E-01	2.300E-02	1.897E-01
4711000	AG	1.849	.174	1.377	.927	9.263E-04	2.913E-05	8.554E-04	1.304E+06	1.515E+00	9.118E-03	3.215E-04	9.440E-03
5112500	SB	.061	.861	.277	.372	2.738E-05	1.425E-04	1.699E-04	5.869E+05	2.699E+00	3.022E-04	1.573E-03	1.875E-03
5513400	CS	1.862	49.245	14.670	6.095	8.324E-04	8.153E-03	8.985E-03	9.608E+06	3.334E+01	9.186E-03	8.997E-02	9.915E-02
5513700	CS	1.784	0.000	1.302	5.399	7.974E-04	0.	7.974E-04	8.510E+06	4.315E+02	8.800E-03	0.	8.800E-03
5613710	BA	0.000	17.304	4.675	5.107	0.	2.864E-03	2.864E-03	8.051E+06	6.575E-05	0.	3.160E-02	3.160E-02
5814400	CE	3.086	2.901	3.034	19.640	1.380E-03	4.801E-04	1.860E-03	3.096E+07	4.061E+01	1.522E-02	5.298E-03	2.052E-02
5914400	PR	46.982	3.116	35.130	19.641	2.100E-02	5.157E-04	2.152E-02	3.096E+07	1.714E+03	2.318E-01	5.691E-03	2.374E-01
6114700	PM	.674	.003	.493	5.648	3.013E-04	4.782E-07	3.014E-04	8.903E+06	3.934E+01	3.325E-03	5.277E-06	3.330E-03
6315400	EU	.265	3.629	1.174	.567	1.187E-04	6.006E-04	7.193E-04	8.945E+05	1.295E+01	1.310E-03	6.628E-03	7.937E-03

TABLE B-XLVII

TMI-2 IF OPERATED 26K HRS AT 2772. MW CONT. CINER-10(LASL) 8/79

44=TIME STEP

7.20000E+07=TOTAL TIME SINCE LAST TIME AT POWER(S)
 1.65492E+08=TOTAL ELAPSED TIME(S)
 6.88811E+19=FISSIONS/S AT LAST TS AT POWER, (22)
 2.77200E+09=POWER (WATTS) AT LAST TS AT POWER (2.77200E+03 MW)
 7.28678E+03=ACCUMULATED FISSIONS (FISSIONS PER BARN-CM)
 1.44006E+04=TOTAL FP IN SIM PER BARN-CM

3.12381E+18=TOTAL ACTIVITY (DIS/S)
 8.44272E+07=TOTAL CURIES
 2.28701E-01=TOTAL BETA DECAY POWER (MW)
 1.14504E-01=TOTAL GAMMA DECAY POWER (MW)
 3.43205E-01=TOTAL DECAY POWER (MW)
 2.07246E-02=TOTAL BETA MFV/F
 1.03762E-02=TOTAL GAMMA MFV/F
 3.11008E-02=TOTAL DECAY MFV/F

ID ZZAAAS	SYM	-----PERCENT OF ALL FP-----				-----MEV/FISS-----			CURIES	DENSITY	---DECAY POWER IN MW---		
		BETA	GAMMA	TOTAL	CURIES	BETA	GAMMA	TOTAL			BETA	GAMMA	TOTAL
3608500	KR	.418	.007	.291	.762	9.662E-05	7.709E-07	8.740E-05	6.435E+05	1.163E+01	9.559E-04	8.507E-06	9.644E-04
3809000	SR	3.046	0.000	2.030	7.030	6.313E-04	0.	6.313E-04	5.935E+06	2.810E+02	6.966E-03	0.	6.966E-03
3909000	Y	14.326	.009	9.449	7.032	2.969E-03	8.929E-07	2.970E-03	5.937E+06	7.311E-02	3.276E-02	9.854E-06	3.277E-02
4410600	RU	.230	0.000	.153	10.536	4.764E-05	0.	4.764E-05	8.895E+06	1.514E+01	5.257E-04	0.	5.257E-04
4510600	RH	33.331	9.184	25.275	10.536	6.908E-03	9.530E-04	7.861E-03	8.895E+06	1.420E-05	7.623E-02	1.052E-02	8.674E-02
4711000	AG	1.267	.099	.974	.491	2.627E-04	9.260E-06	2.719E-04	4.144E+05	4.816E-01	2.899E-03	1.022E-04	3.001E-03
5112500	SB	.099	1.078	.479	.470	7.050E-05	1.067E-04	1.272E-04	4.393E+05	2.020E+00	2.262E-04	1.177E-03	1.403E-03
5513400	CS	2.736	59.525	19.491	7.752	5.671E-04	5.554E-03	6.121E-03	6.545E+06	2.271E+01	6.258E-03	6.129E-02	6.755E-02
5513700	CA	3.748	0.000	2.478	9.919	7.768E-04	0.	7.768E-04	8.290E+06	4.203E+02	8.572E-03	0.	8.572E-03
5613710	BS	0.000	26.882	9.949	9.298	0.	2.789E-03	2.789E-03	7.842E+06	6.405E-03	0.	3.078E-02	3.078E-02
5814400	CE	2.411	1.475	2.166	13.283	4.997E-04	1.739E-04	6.736E-04	1.121E+07	1.471E+01	5.515E-03	1.919E-03	7.434E-03
5914400	PR	36.705	1.900	29.059	13.283	7.607E-03	1.868E-04	7.794E-03	1.121E+07	6.207E-04	8.394E-02	2.061E-03	8.601E-02
6114700	PM	1.075	.003	.718	7.801	2.229E-04	3.538E-07	2.232E-04	6.586E+06	2.910E+01	2.459E-03	3.904E-06	2.463E-03
6315400	EU	.522	5.279	2.109	.966	1.082E-04	5.478E-04	6.560E-04	8.158E+05	1.181E+01	1.194E-03	6.045E-03	7.239E-03
6315500	EU	.060	.194	.135	.506	1.252E-05	2.009E-05	3.261E-05	4.273E+05	3.453E+00	1.381E-04	2.217E-04	3.599E-04

TABLE B-XLVIII

TMI-2 IF OPERATED 26K HRS AT 2772. MW CONT. CINDER-10(LASL) 8/79

45=TIME STEP
 1.80000E+08=TOTAL TIME SINCE LAST TIME AT POWER(S)
 2.73492E+08=TOTAL ELAPSED TIME(S)
 6.88811E+19=FISSIONS/S AT LAST TS AT POWER, (22)
 2.77200E+09=POWER (WATTS) AT LAST TS AT POWER (2.77200E+03 MW)
 7.28678E+03=ACCUMULATED FISSIONS (FISSIONS PER BARN-CM)
 1.43963E+04=TOTAL FP IN SUM PER BARN-CM

1.29457E+18=TOTAL ACTIVITY (DIS/S)
 3.49883E+07=TOTAL CURIES
 6.09451E-02=TOTAL BETA DECAY POWER (MW)
 5.42983E-02=TOTAL GAMMA DECAY POWER (MW)
 1.15243E-01=TOTAL DECAY POWER (MW)
 5.52277E-03=TOTAL BETA MFV/F
 4.92045E-03=TOTAL GAMMA MFV/F
 1.04432E-02=TOTAL DECAY MFV/F

ID ZZAAAS	SYM	-----PERCENT OF ALL FP-----				-----MEV/FISS-----			CURIES	DENSITY	---DECAY POWER IN MW---		
		BETA	GAMMA	TOTAL	CURIES	BETA	GAMMA	TOTAL			BETA	GAMMA	TOTAL
3608500	KR	1.257	.013	.671	1.474	6.944E-05	6.180E-07	7.006E-05	5.159E+05	9.325E+00	7.663E-04	6.819E-06	7.731E-04
3809000	SR	10.505	0.000	5.555	15.591	5.802E-04	0.	5.802E-04	5.455E+06	2.582E+02	6.402E-03	0.	6.402E-03

3909000	Y	49.408	.017	26.137	15.595	2.729E-03	8.207E-07	2.730E-03	5.456E+06	6.719E-02	3.011E-02	9.056E-06	3.012E-02
4410600	RU	.082	0.000	.044	2.429	4.552E-06	0.	4.552E-06	8.500E+05	1.447E+00	5.024E-05	0.	5.024E-05
4510600	RH	11.952	1.841	7.193	2.429	6.601E-04	9.106E-05	7.511E-04	8.500E+05	1.357E-06	7.284E-03	1.005E-03	8.289E-03
5112500	SR	.156	.909	.511	.527	8.596E-06	4.474E-05	5.333E-05	1.842E+05	8.473E-01	9.486E-05	4.937E-04	5.886E-04
5513400	CS	3.246	35.687	18.531	5.914	1.793E-04	1.756E-03	1.935E-03	2.069E+06	7.181E+00	1.979E-03	1.938E-02	2.136E-02
5513700	CS	12.999	0.000	6.874	21.897	7.179E-04	0.	7.179E-04	7.661E+06	3.885E+02	7.922E-03	0.	7.922E-03
5613710	BA	0.000	52.392	24.694	20.715	0.	2.578E-03	2.578E-03	7.248E+06	5.919E-05	0.	2.845E-02	2.845E-02
5814400	CE	.430	.148	.397	1.523	2.375E-05	8.264E-06	3.201E-05	5.329E+05	6.990E-01	2.621E-04	9.120E-05	3.533E-04
5914400	PR	6.545	.180	3.546	1.523	3.615E-04	8.877E-06	3.704E-04	5.329E+05	2.949E-05	3.989E-03	9.796E-05	4.087E-03
6114700	PM	1.634	.003	.855	7.620	9.022E-05	1.432E-07	9.036E-05	2.666E+06	1.178E+01	9.956E-04	1.580E-06	9.972E-04
6315400	EU	1.487	8.448	4.757	1.759	8.213E-05	4.157E-04	4.978E-04	6.191E+05	8.962E+00	9.064E-04	4.587E-03	5.493E-03
6315500	EU	.138	.249	.190	.745	7.633E-06	1.225E-05	1.989E-05	2.606E+05	2.105E+00	8.423E-05	1.352E-04	2.195E-04

APPENDIX C

TMI-2 NOBLE GAS AND HALOGENS AND COMPARISON RESULTS FOLLOWING A LONG IRRADIATION

These 58 tables are based on the same CINDER-10 calculations in Appendix B, the first 29 being for the TMI-2 power history and the remainder for 26 000 hours at a constant, full power level of 2772 MW. Comments preceding the tables in Appendix B also apply here and are not repeated. Graphical summaries of the aggregate gas fractions are shown in Figs. C-1 and C-2 for TMI-2.

The tables list data for each noble gas and halogen isotope (isotopes of Kr and Xe for noble gases and of Br and I for halogens). There are >90 isotopes for these four elements. *The tables list density, curies and beta, gamma, and total decay powers as fractions of the total fission product ensemble for the corresponding quantity.* Each noble gas and halogen is listed that exceeds 0.01% of the curies, beta, gamma or beta + gamma decay power of the aggregate noble gases + halogen value. Therefore, only the radioactive isotopes of any significance appear in the tables.

Where quantities are labeled total gas, all gas, etc., the reference is to noble gas + halogens.

Heading and following each table are values for the total core for all fission products, all gases, etc. Quantities labeled total without further identification refer to all fission products; the product of these and the corresponding fractional values in the detailed nuclide tables provide the actual nuclide value for the total core.

Each table is followed by summations over all noble gases, all halogens, noble gas plus halogens, etc., some information being redundant with data preceeding each table. Here, the first three lines are summations of the quantity labeling each tabular column, and the last four are total fractions of all the fission products. Thus at the instant of shutdown, the total gas accounts for ~2.6 of the 11.9 MeV/fiss total decay power or ~21% of the total. Since only radioactive nuclides produce decay energy, the density and fractional density of these are listed. Thus at the instant of shutdown, <1% of the fission products are gases but these account for ~21% of the total fission product decay power. The fractional values of all noble gases and

the net fractional density of the noble gases that are radioactive are listed in the last two lines following each table.

Five tables of summary output from CINDER-10 follow the detailed gas tables for the TMI-2 and 26 000-hour power histories (Tables C-XXV through C-XXIX for TMI-2 and Tables C-LIV through C-LVIII for the 26 000-hour irradiation).

TABLE C-I

TMI, UNIT 2, 22-STEP POWER HISTORY, FULL CORE CALC., CINDER-10(LASL) 7/79

CONTENT OF NOBLE GASES AND HALOGENS
(EXCEEDING 1.00000E-02 PERCENT OF TOTAL GAS)

TIME STEP 22
 ELAPSED TIME=2.9337*E+07 SEC
 COOLING TIME=0. SEC
 TOTAL ACTIVITY=4.61185E+20
 CURIES IN ALL FP= 1.24645E+19
 IN ALL GAS= 2.33797E+09
 IN HALOGENS= 1.15152E+09
 IN NOBLE GAS= 1.19635E+09
 TOTAL BETA MEV/FISS=6.25950E+00
 TOTAL GAMMA MEV/FISS=5.96669E+00
 TOTAL BETA+GAMMA=1.22262E+01
 FRACTION OF TOTALS IN GAS PRODUCTS
 BETA FRACTION=1.92129E-01
 GAMMA FRACTION=2.40121E-01
 TOTAL FRACTION=2.15550E-01
 FRACTIONAL DENSITY ALL GAS=1.55701E-01
 DENSITY OF RADIOACTIVE GAS=9.7079E-03
 FRACTIONAL GAS ACTIVITY=1.87562E-01

DECAY POWER IN MW FOR ALL FP IS
 TOTAL BETA MW=8.29859E+01
 TOTAL GAMMA MW=7.90095E+01
 TOTAL BETA+GAMMA MW=1.61874E+02
 (MULTIPLY MEV/F BY 1.32416E+01 TO GET MW)

TABULAR VALUES ARE GIVEN AS FRACTIONS OF ALL NUCLIDES

NUCLIDE	DENSITY	CURIES	BETA MEV/F	GAMMA MEV/F	B+G MEV/F
Z A S					
35BR 83 0	3.68159E-06	8.90197E-04	2.57104E-04	6.07705E-06	1.34596E-04
35BR 84 0	1.52144E-06	1.56587E-03	1.86474E-03	2.73050E-03	2.28725E-03
35BR 85 0	1.68411E-07	2.04316E-03	1.81202E-03	1.23582E-04	9.88020E-04
36KR 85 1	1.59682E-05	2.04842E-03	4.14849E-04	3.54401E-04	3.86373E-04
35BR 86 0	4.02545E-08	1.52903E-03	2.41959E-03	4.74413E-03	3.55402E-03
35BR 86 1	3.32699E-05	1.54456E-03	4.24922E-03	2.40652E-03	3.34943E-03
35BR 87 0	9.51548E-08	3.56255E-03	5.79197E-03	5.75120E-03	6.27893E-03
36KR 87 0	8.97724E-06	4.11284E-03	4.89259E-03	3.04846E-03	3.99260E-03
35BR 88 0	3.09518E-08	4.05681E-03	1.11192E-02	7.15401E-03	9.18408E-03
36KR 88 0	2.81383E-05	5.83179E-03	1.29225E-03	1.20625E-02	6.54838E-03
35BR 89 0	6.69701E-09	3.10909E-03	7.80170E-03	5.76292E-03	6.80673E-03
36KR 89 0	6.82596E-07	7.52124E-03	8.32171E-03	1.45104E-02	1.13419E-02
35BR 90 0	1.62379E-09	2.12719E-03	6.34703E-03	4.59135E-03	5.49021E-03
36KR 90 0	1.17806E-07	7.61952E-03	8.06245E-03	1.24632E-02	1.02101E-02
35BR 91 0	1.76431E-10	5.83950E-04	1.85873E-03	1.48822E-03	1.68303E-03
36KR 91 0	2.38163E-08	5.71901E-03	1.31416E-02	3.86972E-03	8.61667E-03
35BR 92 0	6.66430E-12	4.64085E-05	1.53247E-04	1.29568E-04	1.41691E-04

36KR 92 0	2.33042E-09	2.64594E-03	5.65924E-03	1.86033E-03	3.80999E-03
36KR 93 0	5.91037E-10	9.72245E-04	2.39710E-03	1.85441E-03	2.12867E-03
36KR 94 0	4.06216E-11	4.04112E-04	7.45793E-04	6.79478E-04	7.13425E-04
53 I131 0	1.70589E-03	5.12968E-03	9.49227E-04	1.86740E-03	1.34561E-03
53 I132 0	3.10281E-05	7.89009E-03	3.69555E-03	1.64899E-02	9.93437E-03

53 I133 0	4.35304E-04	1.21448E-02	4.51640E-03	6.80189E-03	5.63178E-03
54XE133 0	2.62777E-03	1.20116E-02	1.07084E-03	9.14794E-04	1.00493E-03
53 I134 0	2.04392E-05	1.35294E-02	8.33302E-03	3.28028E-02	2.02749E-02
53 I134 1	8.99221E-09	8.49715E-04	0.	2.56765E-04	1.25308E-04
53 I135 0	1.29056E-04	1.13731E-02	3.99087E-03	1.54855E-02	9.60055E-03
54XE135 0	4.17108E-05	2.63963E-03	7.29170E-04	6.45332E-04	6.88255E-04
54XE135 1	9.02236E-07	2.05325E-03	0.	1.01155E-03	4.93662E-04
53 I136 0	2.19267E-07	5.51900E-03	8.90971E-03	1.14241E-02	1.01368E-02
53 I136 1	7.75383E-09	3.37474E-03	5.93308E-03	6.07651E-03	5.95189E-03
53 I137 0	6.90792E-09	5.84644E-03	7.92047E-03	1.11290E-02	9.48632E-03
54XE137 0	1.18500E-06	1.07448E-02	1.76305E-02	1.96199E-03	9.98387E-03
53 I138 0	9.55350E-09	3.07053E-03	5.80703E-03	7.75600E-03	6.75818E-03
54XE138 0	4.46571E-06	1.09500E-02	5.41979E-03	1.22374E-02	9.25893E-03
53 I139 0	1.68997E-09	1.47107E-03	2.29639E-03	3.40164E-03	2.83578E-03
54XE139 0	1.72825E-07	8.93595E-03	1.42343E-02	7.75144E-03	1.10705E-02
53 I140 0	1.93097E-10	4.69074E-04	8.72778E-04	1.28632E-03	1.07460E-03
54XE140 0	4.08582E-08	5.27795E-03	4.92874E-03	7.99833E-03	6.42678E-03
53 I141 0	1.52886E-11	7.98496E-05	1.38649E-04	2.15480E-04	1.76145E-04
54XE141 0	1.83502E-09	2.22892E-03	3.12205E-03	4.73157E-03	3.90753E-03
54XE142 0	4.67976E-10	8.01361E-04	7.83847E-04	1.32299E-03	1.04696E-03
54XE143 0	1.86109E-11	1.29602E-04	2.07824E-04	3.25889E-04	2.65443E-04

TOTAL GAS	2.16424E+02	2.33787E+09	1.20263E+00	1.43272E+00	2.63535E+00
	1.34940E+01	(RADIODACTIVE GAS DENSITY)			

TOTAL FP	1.39000E+03	1.24645E+10	6.25950E+00	5.96669E+00	1.22262E+01
----------	-------------	-------------	-------------	-------------	-------------

TOTAL GAS FRACTIONS	1.55701E-01	1.87562E-01	1.92129E-01	2.40121E-01	2.15550E-01
	9.70789E-03	(RADIODACTIVE FRACTION OF TOTAL FP)			

NOBLE GAS FRACTIONS	1.48384E-01	9.51795E-02	9.41967E-02	8.99751E-02	9.21365E-02
	4.04436E-03	(NOBLE RADIODACTIVE GAS FRACTION OF TOTAL FP)			

TABLE C-II

TMI, UNIT 2, 22-STEP POWER HISTORY, FULL CORE CALC., CINDER-10(LASL) 7/79

CONTENT OF NOBLE GASES AND HALOGENS
(EXCEEDING 1.00000E-02 PERCENT OF TOTAL GAS)

TIME STEP 23
 ELAPSED TIME=2.93378E+07 SEC
 COOLING TIME=1.00000E+00 SEC
 TOTAL ACTIVITY=4.32726E+20
 CURIES IN ALL FP= 1.18845E+10
 IN ALL GAS= 2.24979E+09
 IN HALOGENS= 1.11210E+09
 IN NOBLE GAS= 1.13769E+09
 TOTAL BETA MEV/FISS=5.68773E+00
 TOTAL GAMMA MEV/FISS=5.53358E+00
 TOTAL BETA+GAMMA=1.12213E+01
 FRACTION OF TOTALS IN GAS PRODUCTS
 BETA FRACTION=1.95897E-01
 GAMMA FRACTION=2.45423E-01
 TOTAL FRACTION=2.20315E-01

FRACTIONAL DENSITY ALL GAS=1.55701E-01
 DENSITY OF RADIOACTIVE GAS=9.70796E-03

FRACTIONAL GAS ACTIVITY=1.89305E-01

DECAY POWER IN MW FP ALL FP IS
 TOTAL BETA MW=7.53147E+01
 TOTAL GAMMA MW=7.32734E+01
 TOTAL BETA+GAMMA MW=1.49589E+02
 (MULTIPLY MEV/F BY 1.32416E+01 TO GET MW)

TABULAR VALUES ARE GIVEN AS FRACTIONS OF ALL NUCLIDES

NUCLIDE	DENSITY	CURIES	BETA MEV/F	GAMMA MEV/F	B+G MEV/F
Z A S					
35BR 83 0	3.69159E-06	9.33641E-04	2.82949E-04	6.55269E-06	1.46650E-04
35BR 84 0	1.52143E-06	1.74715E-03	2.05219E-03	2.94419E-03	2.49206E-03
35BR 85 0	1.68306E-07	2.14153E-03	1.99293E-03	1.33172E-04	1.07583E-03
36KR 85 1	1.59692E-05	2.15937E-03	4.59753E-04	3.82140E-04	4.20973E-04
35BR 86 0	4.00893E-09	1.59703E-03	2.65183E-03	5.09433E-03	3.85630E-03
35BR 86 1	3.16709E-09	1.54708E-03	4.45059E-03	2.47016E-03	3.47397E-03
35BR 87 0	9.44957E-09	3.71054E-03	7.41205E-03	6.15839E-03	6.79383E-03
36KR 87 0	8.97706E-06	4.31349E-03	5.38431E-03	3.28699E-03	4.35006E-03
35BR 89 0	2.97869E-09	4.10476E-03	1.17764E-02	7.42363E-03	9.62992E-03
36KR 89 0	2.81377E-05	6.11528E-03	1.42212E-03	1.30063E-02	7.13464E-03
35BR 89 0	5.76504E-09	2.80704E-03	7.39114E-03	5.34923E-03	6.38421E-03
36KR 89 0	6.81062E-07	7.87058E-03	9.13769E-03	1.56109E-02	1.23299E-02
35BR 90 0	1.06144E-09	1.45356E-03	4.56601E-03	3.23618E-03	3.91023E-03
36KR 90 0	1.15871E-07	7.86017E-03	8.72725E-03	1.32181E-02	1.09418E-02
35BR 91 0	6.21091E-11	2.26811E-04	6.50268E-04	5.07388E-04	5.79810E-04
36KR 91 0	2.21226E-09	5.57155E-03	1.34341E-02	3.87586E-03	8.72064E-03
36KR 92 0	1.60240E-09	1.90819E-03	4.28932E-03	1.37929E-03	2.85429E-03
36KR 93 0	3.43151E-10	5.92026E-04	1.52717E-03	1.16092E-03	1.34656E-03
53 I131 0	1.70588E-03	5.38003E-03	9.33497E-04	2.01356E-03	1.46611E-03
53 I132 0	3.10291E-05	8.26466E-03	4.05605E-03	1.77805E-02	1.08240E-02
53 I133 0	4.35304E-04	1.27375E-02	4.97042E-03	7.33427E-03	6.13611E-03
54XE133 0	2.62797E-03	1.25978E-02	1.70052E-03	9.86394E-04	1.09493E-03
53 I134 0	2.04398E-05	1.41998E-02	9.17055E-03	3.53696E-02	2.20901E-02
53 I134 1	8.96340E-08	9.09239E-04	0.	2.75975E-04	1.36092E-04
53 I135 0	1.29054E-04	1.19280E-02	4.39207E-03	1.66973E-02	1.04601E-02
54XE135 0	4.17139E-05	2.76866E-03	8.02529E-04	6.95892E-04	7.49943E-04
54XE135 1	9.02110E-07	2.15316E-03	0.	1.09057E-03	5.37796E-04
53 I136 0	2.18557E-07	5.76960E-03	9.77361E-03	1.22783E-02	1.10088E-02
53 I136 1	7.64267E-09	3.48870E-03	6.32742E-03	6.45818E-03	6.39190E-03
53 I137 0	6.74385E-08	6.07663E-03	8.50967E-03	1.17150E-02	1.00903E-02
54XE137 0	1.18328E-06	1.12529E-02	1.93747E-02	2.11248E-03	1.08622E-02
53 I138 0	8.65354E-09	2.91702E-03	5.79877E-03	7.57524E-03	6.66973E-03
54XE138 0	4.46307E-06	1.14777E-02	7.06097E-03	1.31874E-02	1.00821E-02
53 I139 0	1.27326E-07	1.16243E-03	1.90409E-03	2.76347E-03	2.32788E-03
54XE139 0	1.70298E-07	9.23607E-03	1.54362E-02	8.23595E-03	1.18855E-02
53 I140 0	8.72090E-11	2.22184E-04	4.33796E-04	6.26407E-04	5.28779E-04
54XE140 0	3.89098E-09	5.26879E-03	5.16430E-03	8.21110E-03	6.66677E-03
54XE141 0	1.23501E-09	1.57326E-03	2.31244E-03	3.43369E-03	2.96536E-03
54XE142 0	2.65817E-10	4.77398E-04	4.89993E-04	8.10291E-04	6.47942E-04
TOTAL GAS	2.16424E+02	2.24979E+09	1.11415E+00	1.35807E+00	2.47222E+00
	1.34939E+01	(RADIOACTIVE GAS DENSITY)			
TOTAL FP	1.39000E+03	1.18845E+10	5.69773E+00	5.53358E+00	1.12213E+01
TOTAL GAS FRACTIONS	1.55701E-01	1.89305E-01	1.95987E-01	2.45423E-01	2.20315E-01
	9.70786E-03	(RADIOACTIVE FRACTION OF TOTAL FP)			

NOBLE GAS

FRACTIONS 1.48388E-01 9.57290E-02 9.43172E-02 9.09572E-02 9.36740E-02
 4.04434E-03 (NOBLE RADIOACTIVE GAS FRACTION OF TOTAL FP)

TABLE C-III

TMI, UNIT 2, 22-STEP POWER HISTORY, FULL CORE CALC., CINDER-10(LASL) 7/79

CONTENT OF NOBLE GASES AND HALOGENS
 (EXCEEDING 1.00000E-02 PERCENT OF TOTAL GAS)

TIME STEP 24
 ELAPSED TIME=2.93378E+07 SEC
 COOLING TIME=4.00000E+00 SEC
 TOTAL ACTIVITY=4.09239E+20
 CURIES IN ALL FP= 1.10794E+10
 IN ALL GAS= 2.10997E+09
 IN HALOGENS= 1.04690E+09
 IN NOBLE GAS= 1.06198E+09
 TOTAL BETA MEV/FISS=4.98347E+00
 TOTAL GAMMA MEV/FISS=5.01853E+00
 TOTAL BETA+GAMMA=1.00020E+01
 FRACTION OF TOTALS IN GAS PRODUCTS
 BETA FRACTION=1.96072E-01
 GAMMA FRACTION=2.48520E-01
 TOTAL FRACTION=2.22388E-01
 FRACTIONAL DENSITY ALL GAS=1.55701E-01
 DENSITY OF RADIOACTIVE GAS=9.70779E-03
 FRACTIONAL GAS ACTIVITY=1.90341E-01

DECAY POWER IN MW FOR ALL FP IS
 TOTAL BETA MW=6.59991E+01
 TOTAL GAMMA MW=6.54534E+01
 TOTAL BETA+GAMMA MW=1.32443E+02
 (MULTIPLY MEV/F BY 1.32416E+01 TO GET MW)

TABULAR VALUES ARE GIVEN AS FRACTIONS OF ALL NUCLIDES

NUCLIDE	DENSITY	CURIES	BETA MEV/F	GAMMA MEV/F	B+G MEV/F
Z A S					
358R 83 0	3.68157E-06	1.00148E-03	3.27934E-04	7.22516E-06	1.64526E-04
358R 84 0	1.52138E-06	1.87405E-03	2.34212E-03	3.24625E-03	2.79577E-03
358R 85 0	1.67913E-07	2.29177E-03	2.26926E-03	1.46496E-04	1.20416E-03
36KR 85 1	1.59691E-05	2.32699E-03	5.23553E-04	4.21358E-04	4.72291E-04
358R 86 0	3.95246E-08	1.68999E-03	2.98402E-03	5.53817E-03	4.26558E-03
358R 86 1	2.74561E-09	1.43399E-03	4.40354E-03	2.36120E-03	3.37879E-03
358R 87 0	9.22386E-08	3.88508E-03	8.25745E-03	6.62822E-03	7.43998E-03
36KR 87 0	8.97645E-06	4.62658E-03	6.14480E-03	3.62408E-03	4.88002E-03
358R 88 0	2.63230E-08	3.89098E-03	1.19776E-02	7.23361E-03	9.54748E-03
36KR 89 0	2.81356E-05	6.56019E-03	1.62297E-03	1.43400E-02	8.00379E-03
358R 89 0	3.63586E-09	1.39396E-03	5.32015E-03	3.71985E-03	4.51719E-03
36KR 89 0	6.75756E-07	9.37667E-03	1.03478E-02	1.70790E-02	1.37252E-02
358R 90 0	2.91062E-10	4.27549E-04	1.42901E-03	9.78480E-04	1.20295E-03
36KR 90 0	1.09392E-07	7.95983E-03	2.40359E-03	1.37596E-02	1.15892E-02
36KR 91 0	1.74700E-08	4.71949E-03	1.21090E-02	3.37484E-03	7.72611E-03
36KR 92 0	5.17751E-10	6.61340E-04	1.58178E-03	4.91398E-04	1.03468E-03
36KR 93 0	6.67487E-11	1.23527E-04	3.39041E-04	2.48994E-04	2.93860E-04
53 I131 0	1.70588E-03	5.77095E-03	1.06542E-03	2.22021E-03	1.64484E-03

53 I132 0	3.10291E-05	9.85516E-03	4.62924E-03	1.96052E-02	1.21435E-02
53 I133 0	4.35304E-04	1.36630E-02	5.67293E-03	8.08696E-03	6.88413E-03
54XE133 0	2.62797E-03	1.35132E-02	1.37017E-03	1.08763E-03	1.22841E-03
53 I134 0	2.04377E-05	1.52201E-02	1.04660E-02	3.89974E-02	2.47817E-02
53 I134 1	8.87752E-09	9.65960E-04	0.	3.01382E-04	1.51219E-04
53 I135 0	1.29049E-04	1.27941E-02	5.01244E-03	1.94101E-02	1.17347E-02
54XE135 0	4.17228E-05	2.97049E-03	9.15141E-04	7.67477E-04	8.41548E-04
54XE135 1	9.01734E-07	2.30964E-03	0.	1.20200E-03	6.03104E-04
53 I136 0	2.16249E-07	5.12344E-03	1.11370E-02	1.33955E-02	1.22204E-02
53 I136 1	7.31864E-09	3.58353E-03	6.91544E-03	6.81906E-03	6.86708E-03
53 I137 0	6.25244E-08	5.97359E-03	9.00455E-03	1.19761E-02	1.04955E-02
54XE137 0	1.17788E-06	1.20154E-02	2.20119E-02	2.31865E-03	1.21307E-02
53 I138 0	6.36376E-02	2.30102E-03	4.85862E-03	6.14250E-03	5.50281E-03
54XE138 0	4.45459E-06	1.22882E-02	8.04351E-03	1.45132E-02	1.12897E-02
53 I139 0	5.36389E-10	5.25280E-04	9.15493E-04	1.28365E-03	1.10022E-03
54XE139 0	1.62425E-07	9.44913E-03	1.68031E-02	8.66133E-03	1.27179E-02
54XE140 0	3.34424E-09	5.77937E-03	5.06530E-03	7.78160E-03	6.42851E-03
54XE141 0	3.69564E-10	5.04990E-04	7.89769E-04	1.13295E-03	9.61960E-04
54XE142 0	4.83516E-11	9.31478E-05	1.01725E-04	1.62517E-04	1.32228E-04
TOTAL GAS	2.16424E+02	2.10887E+09	9.77121E-01	1.24721E+00	2.22433E+00
	1.34938E+01	(RADIOACTIVE GAS DENSITY)			
TOTAL FP	1.39000E+03	1.10794E+10	4.98347E+00	5.01853E+00	1.00020E+01
TOTAL GAS FRACTIONS	1.55701E-01	1.90341E-01	1.96072E-01	2.48520E-01	2.22398E-01
	9.70779E-03	(RADIOACTIVE FRACTION OF TOTAL FP)			
NOBLE GAS FRACTIONS	1.48388E-01	9.58511E-02	9.71785E-02	9.11393E-02	9.41483E-02
	4.04430E-03	(NOBLE RADIOACTIVE GAS FRACTION OF TOTAL FP)			

TABLE C-IV

TMI, UNIT 2, 22-STEP POWER HISTORY, FULL CORE CALC., CINDER-10(LASL) 7/79

CONTENT OF NOBLE GASES AND HALOGENS
(EXCEEDING 1.00000E-02 PERCENT OF TOTAL GAS)

TIME STEP 25
 ELAPSED TIME=2.93379E+07 SEC
 COOLING TIME=1.00000E+01 SEC
 TOTAL ACTIVITY=3.80462E+20
 CURIES IN ALL FP= 1.02927E+10
 IN ALL GAS= 1.96710E+09
 IN HALOGENS= 9.79259E+09
 IN NOBLE GAS= 9.87141E+09
 TOTAL BETA MEV/FISS=4.34924E+00
 TOTAL GAMMA MEV/FISS=4.56194E+00
 TOTAL BETA+GAMMA=9.91119E+00
 FRACTION OF TOTALS IN GAS PRODUCTS
 BETA FRACTION=1.96071E-01
 GAMMA FRACTION=2.50597E-01
 TOTAL FRACTION=2.23496E-01
 FRACTIONAL DENSITY ALL GAS=1.55701E-01
 DENSITY OF RADIOACTIVE GAS=9.70779E-03
 FRACTIONAL GAS ACTIVITY=1.91301E-01

DECAY POWER IN MW FOR ALL FP IS

TOTAL BETA MW=5.75910E+01
 TOTAL GAMMA MW=6.74074E+01
 TOTAL BETA+GAMMA MW=1.17999E+02
 (MULTIPLY MEV/F BY 1.32416E+01 TO GET MW)

TABULAR VALUES ARE GIVEN AS FRACTIONS OF ALL NUCLIDES

NUCLIDE	DENSITY	CURIES	BETA MEV/F	GAMMA MEV/F	B+G MEV/F
Z A S					
359R 83 0	3.68153E-06	1.07906E-03	3.70022E-04	7.94821E-06	1.84664E-04
359R 94 0	1.52125E-06	2.01907E-03	2.69343E-03	3.57085E-03	3.13773E-03
359R 85 0	1.66804E-07	2.45303E-03	2.58300E-03	1.60094E-04	1.34263E-03
36KR 85 1	1.59680E-05	2.50727E-03	5.99930E-04	4.63528E-04	5.30101E-04
359R 96 0	3.81512E-08	1.75661E-03	3.30036E-03	5.98078E-03	4.62136E-03
359R 86 1	2.09176E-09	1.17715E-03	3.84409E-03	1.97894E-03	2.88926E-03
359R 87 0	8.69820E-08	3.94753E-03	9.92237E-03	6.87607E-03	7.97480E-03
36KR 87 0	9.97494E-06	4.98421E-03	7.03969E-03	3.98614E-03	5.47647E-03
359R 88 0	2.03175E-08	3.23597E-03	1.05047E-02	6.14211E-02	9.27134E-03
36KR 88 0	2.81300E-05	7.06708E-03	1.85927E-03	1.57722E-02	8.98176E-03
359R 89 0	1.44290E-09	9.11999E-04	2.41220E-03	1.62399E-03	2.01210E-03
36KR 89 0	6.63260E-07	8.85881E-03	1.16375E-02	1.84409E-02	1.51204E-02
359R 90 0	2.16449E-11	3.42593E-05	1.21765E-04	8.00478E-05	1.00409E-04
36KR 90 0	9.64223E-09	7.55971E-03	9.49740E-03	1.33422E-02	1.14657E-02
36KR 91 0	1.08327E-08	3.15317E-03	9.60270E-03	2.30210E-03	5.37721E-03
36KR 92 0	5.40130E-11	7.43380E-05	1.89079E-04	5.63947E-05	1.21153E-04
53 I131 0	1.70588E-03	6.21809E-03	1.22079E-03	2.44242E-03	1.84618E-03
53 I132 0	3.10279E-05	9.55199E-03	5.30429E-03	2.15674E-02	1.36299E-02
53 I133 0	4.35302E-04	1.47216E-02	6.50004E-03	8.89634E-03	7.72679E-03
54XE133 0	2.62797E-03	1.45602E-02	1.56998E-03	1.19648E-03	1.37877E-03
53 I134 0	2.04354E-05	1.63974E-02	1.19909E-02	4.28957E-02	2.78121E-02
53 I134 1	8.70822E-08	1.02095E-03	0.	3.25224E-04	1.66493E-04
53 I135 0	1.29035E-04	1.37939E-02	5.74277E-03	2.02505E-02	1.31698E-02
54XE135 0	4.17409E-05	3.70202E-03	1.05019E-03	8.44658E-04	9.44972E-04
54XE135 1	9.00983E-07	2.48544E-03	0.	1.32120E-03	6.76367E-04
53 I136 0	2.10959E-07	4.43649E-03	1.73371E-02	1.43757E-02	1.33807E-02
53 I136 1	6.71122E-08	3.54071E-03	7.26622E-03	6.87896E-03	7.06797E-03
53 I137 0	5.32477E-08	5.48145E-03	9.79690E-03	1.12200E-02	1.00325E-02
54XE137 0	1.15604E-06	1.29162E-02	2.49591E-02	2.52508E-03	1.34788E-02
53 I138 0	3.37867E-09	1.31632E-03	2.95572E-03	3.58761E-03	3.27921E-03
54XE138 0	4.43598E-06	1.31947E-02	9.17773E-03	1.58987E-02	1.26194E-02
53 I139 0	9.49237E-11	1.00054E-04	1.95443E-04	2.49637E-04	2.18306E-04
54XE139 0	1.46911E-07	9.20977E-03	1.74144E-02	8.61812E-03	1.29113E-02
54XE140 0	2.46357E-08	4.58729E-03	4.27604E-03	6.30613E-03	5.31531E-03
TOTAL GAS	2.16424E+02	1.96710E+09	9.49411E-01	1.14321E+00	1.99162E+00
	1.34936E+01	(RADIOACTIVE GAS DENSITY)			
TOTAL FP	1.39000E+03	1.02927E+10	4.34924E+00	4.56194E+00	8.91119E+00
TOTAL GAS FRACTIONS	1.55701E-01	1.91301E-01	1.95771E-01	2.50597E-01	2.23496E-01
	9.70765E-03	(RADIOACTIVE FRACTION OF TOTAL FP)			
NOBLE GAS FRACTIONS	1.48393E-01	9.59999E-02	9.79937E-02	9.13966E-02	9.46064E-02
	4.04423E-03	(NOBLE RADIOACTIVE GAS FRACTION OF TOTAL FP)			

TABLE C-V

TMI, UNIT 2, 22-STEP POWER HISTORY, FULL CORE CALC., CINDER-10(LASL) 7/79

CONTENT OF NOBLE GASES AND HALOGENS
(EXCEEDING 1.00000E-02 PERCENT OF TOTAL GAS)

TIME STEP 26
 ELAPSED TIME=2.93370E+07 SEC
 COOLING TIME=4.00000E+01 SEC
 TOTAL ACTIVITY=3.25417E+20
 CURIES IN ALL FP= 9.79505E+09
 IN ALL GAS= 1.67208E+09
 IN HALOGENS= 8.49583E+08
 IN NOBLE GAS= 8.23493E+08
 TOTAL BETA MEV/FISS=3.30255E+00
 TOTAL GAMMA MEV/FISS=3.71465E+00
 TOTAL BETA+GAMMA=7.01722E+00
 FRACTION OF TOTALS IN GAS PRODUCTS
 BETA FRACTION=1.84439E-01
 GAMMA FRACTION=2.52049E-01
 TOTAL FRACTION=2.20229E-01
 FRACTIONAL DENSITY ALL GAS=1.55700E-01
 DENSITY OF RADIOACTIVE GAS=9.70705E-03
 FRACTIONAL GAS ACTIVITY=1.90116E-01

DECAY POWER IN MW FOR ALL FP IS
 TOTAL BETA MW=4.37310E+01
 TOTAL GAMMA MW=4.91893E+01
 TOTAL BETA+GAMMA MW=9.29193E+01
 (MULTIPLY MEV/F BY 1.32416E+01 TO GET MW)

TABULAR VALUES ARE GIVEN AS FRACTIONS OF ALL NUCLIDES

NUCLIDE	DENSITY	CURIES	BETA MEV/F	GAMMA MEV/F	B+G MEV/F
Z A S					
35BR 83 0	3.68075E-06	1.26131E-03	4.87191E-04	9.75899E-06	2.34455E-04
35BR 84 0	1.51969E-05	2.35919E-03	3.53029E-03	4.38081E-03	3.98052E-03
35BR 84 1	5.94499E-09	4.89932E-05	5.21994E-05	1.43461E-04	1.00510E-04
35BR 85 0	1.56901E-07	2.69771E-03	3.19971E-03	1.84937E-04	1.60379E-03
36KR 85 1	1.59671E-05	2.93120E-03	7.90022E-04	5.69217E-04	6.73135E-04
35BR 36 0	2.92857E-09	1.57650E-03	1.33634E-03	5.54393E-03	4.50492E-03
35BR 86 1	5.84707E-10	3.94704E-04	1.41509E-03	6.79340E-04	1.02561E-03
35BR 87 0	6.08783E-09	3.23019E-03	8.22391E-03	5.91020E-03	6.99911E-03
36KR 87 0	8.96141E-04	5.81851E-03	9.25683E-03	4.88794E-03	6.94409E-03
35BR 88 0	5.49528E-09	1.02329E-03	3.74169E-03	2.04016E-03	2.84096E-03
36KR 88 0	2.80869E-05	8.24981E-03	2.44479E-03	1.93398E-02	1.13895E-02
36KR 89 0	5.95674E-07	9.30199E-03	1.37641E-02	2.03393E-02	1.72448E-02
36KR 90 0	5.06623E-09	4.54391E-03	6.57179E-03	8.60921E-03	7.65029E-03
36KR 91 0	9.92434E-10	3.37741E-04	1.03792E-03	2.59010E-04	6.25592E-04
53 I131 0	1.70583E-03	7.25999E-03	1.67769E-03	2.99950E-03	2.34447E-03
53 I132 0	3.10274E-05	1.11675E-02	6.99529E-03	2.64861E-02	1.73094E-02
53 I133 0	4.35295E-04	1.77115E-02	8.56200E-03	1.09253E-02	9.81210E-03
54XE133 0	2.62798E-03	1.70231E-02	2.06757E-03	1.46939E-03	1.75091E-03
53 I134 0	2.04229E-05	1.91594E-02	1.57915E-02	5.26475E-02	3.52971E-02
53 I134 1	7.90897E-09	1.08409E-03	0.	3.62745E-04	1.92025E-04
53 I135 0	1.28945E-04	1.61043E-02	7.55761E-03	2.48521E-02	1.67127E-02
54XE135 0	4.18313E-05	3.75175E-03	1.39603E-03	1.03956E-03	1.20262E-03
54XE135 1	8.97271E-07	2.89399E-03	0.	1.61586E-03	8.55381E-04

53 I136 0	1.77671E-07	6.33780E-03	1.36935E-02	1.48688E-02	1.43109E-02
53 I136 1	4.35168E-09	2.69422E-03	6.27482E-03	5.47781E-03	5.81997E-03
53 I137 0	2.29742E-09	2.76506E-03	4.99269E-03	5.94512E-03	5.49688E-03
54XE137 0	1.09289E-06	1.40441E-02	3.09187E-02	2.90649E-03	1.60430E-02
53 I138 0	1.39003E-10	6.29604E-05	1.59991E-04	1.79960E-04	1.70091E-04
54XE138 0	4.33204E-06	1.50541E-02	1.19036E-02	1.90679E-02	1.56491E-02
54XE139 0	8.78587E-08	6.43878E-03	1.37153E-02	6.32954E-03	9.80552E-03
54XE140 0	5.33984E-09	1.16749E-03	1.22059E-03	1.67863E-03	1.46306E-03
TOTAL GAS	2.16424E+02	1.67208E+09	6.09115E-01	9.36279E-01	1.54539E+00
	1.34928E+01	(RADIOACTIVE GAS DENSITY)			
TOTAL FP	1.39000E+03	9.79505E+09	3.30255E+00	3.71468E+00	7.01722E+00
TOTAL GAS FRACTIONS	1.55700E-01	1.90116E-01	1.84438E-01	2.52049E-01	2.20229E-01
	9.70705E-03	(RADIOACTIVE FRACTION OF TOTAL FP)			
NOBLE GAS FRACTIONS	1.48388E-01	9.36314E-02	9.49904E-02	8.83396E-02	9.14179E-02
	4.04388E-03	(NOBLE RADIOACTIVE GAS FRACTION OF TOTAL FP)			

TABLE C-VI

TMI, UNIT 2, 22-STEP POWER HISTORY, FULL CORE CALC., CINDER-10(LASL) 7/79

CONTENT OF NOBLE GASES AND HALOGENS
(EXCEEDING 1.00000E-02 PERCENT OF TOTAL GAS)

TIME STEP 27
 ELAPSED TIME=2.93379E+07 SEC
 COOLING TIME=1.00000E+02 SEC
 TOTAL ACTIVITY=2.97987E+20
 CURIES IN ALL FP= 7.79331E+03
 IN ALL GAS= 1.45754E+03
 IN HALOGENS= 7.54374E+09
 IN NOBLE GAS= 7.03162E+09
 TOTAL BETA MEV/FISS=2.66002E+00
 TOTAL GAMMA MEV/FISS=3.10892E+00
 TOTAL BETA+GAMMA=5.76894E+00
 FRACTION OF TOTALS IN GAS PRODUCTS
 BETA FRACTION=1.59498E-01
 GAMMA FRACTION=2.53515E-01
 TOTAL FRACTION=2.14775E-01
 FRACTIONAL DENSITY ALL GAS=1.55700E-01
 DENSITY OF RADIOACTIVE GAS=9.70503E-03
 FRACTIONAL GAS ACTIVITY=1.87264E-01

DECAY POWER IN MW FOR ALL FP IS
 TOTAL BETA MW=3.52227E+01
 TOTAL GAMMA MW=4.11672E+01
 TOTAL BETA+GAMMA MW=7.63901E+01
 (MULTIPLY MEV/F BY 1.32416E+01 TO GET MW)

TABULAR VALUES ARE GIVEN AS FRACTIONS OF ALL NUCLIDES

NUCLIDE	DENSITY	CURIES	BETA MEV/F	GAMMA MEV/F	B+G MEV/F
Z A S					
35BR 83 0	3.67601E-06	1.42343E-03	6.04094E-04	1.16455E-05	2.94819E-04
35BR 84 0	1.51234E-06	2.65193E-03	4.35182E-03	5.20907E-03	4.81841E-03

359R 84 1	5.29637E-09	4.92210E-05	5.77375E-05	1.52712E-04	1.08920E-04
358R 85 0	1.29760E-07	2.52107E-03	3.29541E-03	1.82747E-04	1.61336E-03
36KR 85 1	1.59506E-05	3.21097E-03	9.87453E-04	6.79848E-04	8.18455E-04
359R 86 0	1.46212E-08	9.89396E-04	2.06807E-03	3.30711E-03	2.73580E-03
359R 86 1	4.77013E-11	3.54644E-05	1.43331E-04	6.62202E-05	1.01776E-04
359R 87 0	2.89033E-09	1.73326E-03	4.94966E-03	3.35331E-03	4.04271E-03
36KR 87 0	9.91199E-06	6.53952E-03	1.14293E-02	5.80804E-03	8.39997E-03
359R 88 0	4.01813E-10	9.45477E-05	3.39677E-04	1.78242E-04	2.52679E-04
36KR 88 0	2.79763E-05	9.28549E-03	3.02338E-03	2.30171E-02	1.37981E-02
36KR 89 0	4.79362E-07	8.44097E-03	1.37233E-02	1.95162E-02	1.68451E-02
36KR 90 0	1.39796E-09	1.44799E-03	2.25139E-03	2.83846E-03	2.56777E-03
53 I131 0	1.70588E-09	9.21490E-03	1.99604E-03	3.58394E-03	2.85177E-03
53 I132 0	3.10263E-05	1.26189E-02	9.67227E-03	3.16457E-02	2.10528E-02
53 I133 0	4.35276E-04	1.94479E-02	1.06272E-02	1.30534E-02	1.19347E-02
54XE133 0	2.62798E-03	1.92359E-02	2.56699E-03	1.75569E-03	2.12977E-03
54XE133 1	4.34798E-05	7.54994E-04	0.	1.96887E-04	1.06104E-04
53 I134 0	2.03934E-05	2.15196E-02	1.95652E-02	6.28144E-02	4.29725E-02
53 I134 1	6.52379E-08	1.01047E-03	0.	3.57514E-04	1.92657E-04
53 I135 0	1.28729E-04	1.91672E-02	9.36742E-03	2.96446E-02	2.02949E-02
54XE135 0	4.20115E-05	4.25770E-03	1.72924E-03	1.24746E-03	1.46914E-03
54XE135 1	9.90052E-07	3.24375E-03	0.	1.91517E-03	1.03210E-03
53 I136 0	1.13399E-07	4.57023E-03	1.09431E-02	1.13391E-02	1.11104E-02
53 I136 1	1.82365E-08	1.27527E-03	3.23995E-03	2.75188E-03	2.97646E-03
53 I137 0	4.23674E-09	5.74197E-04	1.14312E-03	1.30998E-03	1.23304E-03
54XE137 0	9.28227E-07	1.34786E-02	3.24979E-02	2.94955E-03	1.65741E-02
54XE138 0	4.12579E-05	1.62010E-02	1.39570E-02	2.16984E-02	1.81289E-02
54XE139 0	3.13841E-09	2.59998E-03	6.09266E-03	2.70152E-03	4.26054E-03
TOTAL GAS	2.16423E+02	1.45754E+09	4.50869E-01	7.88158E-01	1.23903E+00
	1.34914E+01	(RADIODACTIVE GAS DENSITY)			
TOTAL FP	1.39000E+03	7.78331E+09	2.65002E+00	3.10892E+00	5.76894E+00
TOTAL GAS FRACTIONS	1.55700E-01	1.87264E-01	1.69498E-01	2.53515E-01	2.14775E-01
	9.70603E-03	(RADIODACTIVE FRACTION OF TOTAL FP)			
NOBLE GAS FRACTIONS	1.49388E-01	9.03623E-02	9.83268E-02	8.44963E-02	8.62625E-02
	4.04332E-03	(NOBLE RADIODACTIVE GAS FRACTION OF TOTAL FP)			

TABLE C-VII

TMI, UNIT 2, 22-STEP POWER HISTORY, FULL CORE CALC., CINDER-10(LASL) 7/79

CONTENT OF NOBLE GASES AND HALOGENS
(EXCEEDING 1.00000E-02 PERCENT OF TOTAL GAS)

TIME STEP 29
 ELAPSED TIME=2.93382E+07 SEC
 COOLING TIME=4.00000E+02 SEC
 TOTAL ACTIVITY=2.36930E+20
 CURIES IN ALL FP= 6.40782E+09
 IN ALL GAS= 1.19754E+03
 IN HALOGENS= 6.57455E+08
 IN NOBLE GAS= 5.34091E+08
 TOTAL BETA MEV/FISS=1.99353E+00

TOTAL GAMMA MEV/FISS=2.34725E+00
 TOTAL BETA+GAMMA=4.23079E+00

FRACTION OF TOTALS IN GAS PRODUCTS
 BETA FRACTION=1.49023E-01
 GAMMA FRACTION=2.71311E-01
 TOTAL FRACTION=2.16424E-01
 FRACTIONAL DENSITY ALL GAS=1.55699E-01
 DENSITY OF RADIOACTIVE GAS=9.70226E-03
 FRACTIONAL GAS ACTIVITY=1.87091E-01

DECAY POWER IN MW FOR ALL FP IS
 TOTAL BETA MW=2.49410E+01
 TOTAL GAMMA MW=3.10914E+01
 TOTAL BETA+GAMMA MW=5.60224E+01
 (MULTIPLY MEV/F BY 1.32416E+01 TO GET MW)

TABULAR VALUES ARE GIVEN AS FRACTIONS OF ALL NUCLIDES

NUCLIDE	DENSITY	CURIES	BETA MEV/F	GAMMA MEV/F	B+G MEV/F
Z A S					
353R 83 0	3.62514E-05	1.70692E-03	9.41326E-04	1.52109E-05	3.82994E-04
353R 84 0	1.42329E-05	3.03673E-03	5.79729E-03	6.49314E-03	6.18335E-03
359R 95 0	4.00731E-08	9.46725E-04	1.43289E-03	7.47501E-05	6.79399E-04
36KR 85 1	1.53495E-05	3.99770E-03	1.37497E-03	8.94130E-04	1.10818E-03
358R 87 0	6.75957E-10	5.07401E-05	1.64945E-04	1.06926E-04	1.32711E-04
36KR 87 0	8.54187E-04	7.62064E-03	1.54709E-02	7.37332E-03	1.09783E-02
36KR 89 0	2.74055E-05	1.10606E-02	4.19265E-03	2.98640E-02	1.84307E-02
36KR 89 0	1.59751E-07	3.42774E-03	6.47230E-03	8.63240E-03	7.67073E-03
53 I131 0	1.70597E-03	7.98927E-03	2.81892E-03	4.74694E-03	3.88859E-03
53 I132 0	3.10209E-05	1.53415E-02	1.22453E-02	4.19071E-02	2.87018E-02
53 I133 0	4.35099E-04	2.36398E-02	1.50022E-02	1.72822E-02	1.62671E-02
54XE133 0	2.62800E-03	2.33908E-02	3.62527E-03	2.32542E-03	2.90411E-03
54XE133 1	4.34787E-05	2.18742E-04	0.	2.60770E-04	1.44676E-04
53 I134 0	2.01702E-05	2.50002E-02	2.73286E-02	8.22869E-02	5.78197E-02
53 I134 1	2.49115E-08	4.69194E-04	0.	1.80819E-04	1.00319E-04
53 I135 0	1.27606E-04	2.18987E-02	1.31137E-02	3.89215E-02	2.74320E-02
54XE135 0	4.28995E-05	5.28672E-03	2.49229E-03	1.68717E-03	2.04561E-03
54XE135 1	3.57676E-07	3.90089E-03	0.	2.44435E-03	1.35614E-03
53 I136 0	9.39705E-09	4.60593E-04	1.25896E-03	1.24455E-03	1.25542E-03
54XE137 0	3.78252E-07	6.67885E-03	1.87023E-02	1.59196E-03	9.20942E-03
54XE138 0	3.23229E-04	1.54338E-02	1.54421E-02	2.25155E-02	1.93664E-02
TOTAL GAS	2.16422E+00	1.19754E+09	2.78907E-01	6.36836E-01	9.15642E-01
	1.34861E+01	(RADIOACTIVE GAS DENSITY)			
TOTAL FP	1.39000E+03	6.40097E+09	1.98353E+00	2.34725E+00	4.23079E+00
TOTAL GAS FRACTIONS	1.55699E-01	1.87091E-01	1.49023E-01	2.71311E-01	2.16424E-01
	9.70226E-03	(RADIOACTIVE FRACTION OF TOTAL FP)			
NOBLE GAS FRACTIONS	1.48389E-01	9.34394E-02	6.78235E-02	7.77154E-02	7.33116E-02
	4.04139E-03	(NOBLE RADIOACTIVE GAS FRACTION OF TOTAL FP)			

TABLE C-VIII

THI, UNIT 2, 22-STEP POWER HISTORY, FULL CORE CALC., CINDER-10(LASL) 7/79

CONTENT OF NOBLE GASES AND HALOGENS
(EXCEPTING 1.0000E-02 PERCENT OF TOTAL GAS)

TIME STEP 29
 ELAPSED TIME=2.93399E+07 SEC
 COOLING TIME=1.00007E+03 SEC
 TOTAL ACTIVITY=2.04110E+20
 CURIES IN ALL FP= 5.51649E+09
 IN ALL GAS= 1.07219E+09
 IN HALOGENS= 6.39396E+09
 IN NOBLE GAS= 4.32789E+09
 TOTAL BETA MEV/FISS=1.47043E+00
 TOTAL GAMMA MEV/FISS=1.93313E+00
 TOTAL BETA+GAMMA=3.40356E+00
 FRACTION OF TOTALS IN GAS PRODUCTS
 BETA FRACTION=1.46081E-01
 GAMMA FRACTION=2.97667E-01
 TOTAL FRACTION=2.32178E-01
 FRACTIONAL DENSITY ALL GAS=1.55699E-01
 DENSITY OF RADIOACTIVE GAS=9.69623E-03
 FRACTIONAL GAS ACTIVITY=1.94359E-01

DECAY POWER IN MW FOR ALL FP IS
 TOTAL BETA MW=1.94709E+01
 TOTAL GAMMA MW=2.55977E+01
 TOTAL BETA+GAMMA MW=4.50686E+01
 (MULTIPLY MEV/F BY 1.32416E+01 TO GET MW)

TABULAR VALUES ARE GIVEN AS FRACTIONS OF ALL NUCLIDES

NUCLIDE	DENSITY	CURIES	BETA MEV/F	GAMMA MEV/F	B+G MEV/F
Z A S					
35R 83 0	3.50053E-06	1.91253E-03	1.04067E-03	1.78351E-05	4.59729E-04
35R 84 0	1.17331E-06	2.90399E-03	6.12427E-03	6.50216E-03	6.33890E-03
36KR 85 1	1.54809E-05	4.53007E-03	1.72034E-03	1.06050E-03	1.34556E-03
36KR 87 0	7.79794E-06	9.07219E-03	1.80913E-02	8.17315E-03	1.24591E-02
36KR 88 0	2.62978E-05	1.23150E-02	5.14115E-03	3.47960E-02	2.19843E-02
36KR 89 0	1.78162E-06	4.43567E-04	9.24507E-04	1.16897E-03	1.06340E-03
53 I131 0	1.70587E-03	1.15905E-02	3.61082E-03	5.76380E-03	4.83365E-03
53 I132 0	3.10089E-05	1.77939E-02	1.56793E-02	5.08649E-02	3.56637E-02
53 I133 0	4.34336E-04	2.73902E-02	1.91831E-02	2.09476E-02	2.01853E-02
54XE133 0	2.62805E-03	2.71410E-02	4.64382E-03	2.82364E-03	3.61000E-03
54XE133 1	4.34768E-05	1.06516E-03	0.	3.16620E-04	1.79831E-04
53 I134 0	1.94751E-05	2.91296E-02	3.37997E-02	9.64716E-02	6.93956E-02
53 I135 0	1.25337E-04	2.49669E-02	1.65057E-02	4.64376E-02	3.35062E-02
54XE135 0	4.46148E-05	6.37949E-03	3.32012E-03	2.13052E-03	2.64446E-03
54XE135 1	9.07675E-07	4.15379E-03	0.	2.79497E-03	1.58745E-03
54XE137 0	6.22084E-08	1.27451E-03	3.93994E-03	3.17907E-04	1.88273E-03
54XE138 0	1.98383E-06	1.09914E-02	1.21406E-02	1.67798E-02	1.47756E-02
TOTAL GAS	2.16422E+02	1.07219E+09	2.14802E-01	5.75429E-01	7.90231E-01
	1.34773E+01	(RADIOACTIVE GAS DENSITY)			
TOTAL FP	1.39000E+03	5.51649E+09	1.47043E+00	1.93313E+00	3.40356E+00

TOTAL GAS
FRACTIONS 1.55699E-01 1.94359E-01 1.46081E-01 2.97667E-01 2.32178E-01
9.69623E-03 (RADIOACTIVE FRACTION OF TOTAL FP)

NOBLE GAS
FRACTIONS 1.48392E-01 7.84539E-02 4.99292E-02 7.04828E-02 6.16031E-02
4.03924E-03 (NOBLE RADIOACTIVE GAS FRACTION OF TOTAL FP)

TABLE C-IX

TMI, UNIT 2, 22-STEP POWER HISTORY, FULL CORE CALC., CINDER-10(LASL) 7/79

CONTENT OF NOBLE GASES AND HALOGENS
(EXCEEDING 1.00000E-02 PERCENT OF TOTAL GAS)

TIME STEP 30
ELAPSED TIME=2.93414E+07 SEC
COOLING TIME=3.60000E+03 SEC
TOTAL ACTIVITY=1.57103E+20
CURIES IN ALL FP= 4.24604E+09
IN ALL GAS= 9.20610E+09
IN HALOGENS= 5.77107E+09
IN NOBLE GAS= 3.43503E+09
TOTAL BETA MEV/FISS=9.66806E-01
TOTAL GAMMA MEV/FISS=1.30642E+00
TOTAL BETA+GAMMA=2.27323E+00
FRACTION OF TOTALS IN GAS PRODUCTS
BETA FRACTION=1.68336E-01
GAMMA FRACTION=3.59191E-01
TOTAL FRACTION=2.78020E-01
FRACTIONAL DENSITY ALL GAS=1.55697E-01
DENSITY OF RADIOACTIVE GAS=9.67117E-03
FRACTIONAL GAS ACTIVITY=2.16816E-01

DECAY POWER IN MW FOR ALL FP IS
TOTAL BETA MW=1.28021E+01
TOTAL GAMMA MW=1.72991E+01
TOTAL BETA+GAMMA MW=3.01012E+01
(MULTIPLY MEV/F BY 1.32416E+01 TO GET MW)

TABULAR VALUES ARE GIVEN AS FRACTIONS OF ALL NUCLIDES

NUCLIDE	DENSITY	CURIES	BETA MEV/F	GAMMA MEV/F	B+G MEV/F
Z A S					
358R 83 0	2.92557E-06	2.07660E-03	1.32277E-03	2.20555E-05	5.75250E-04
358R 84 0	4.58489E-07	1.47369E-03	3.63824E-03	3.75807E-03	3.70711E-03
36KR 85 1	1.38474E-05	5.26553E-03	2.34741E-03	1.40365E-03	1.80205E-03
36KR 87 0	5.25219E-06	7.06366E-03	1.85326E-02	8.14567E-03	1.25632E-02
36KR 88 0	2.19924E-05	1.33903E-02	6.53913E-03	4.30586E-02	2.75268E-02
53 I131 0	1.70476E-03	1.50486E-02	5.49819E-03	8.52319E-03	7.23240E-03
53 I132 0	3.09386E-05	2.30657E-02	2.37930E-02	7.50952E-02	5.32763E-02
53 I133 0	4.27733E-04	3.50319E-02	2.87324E-02	3.05253E-02	2.97629E-02
54XE133 0	2.62816E-03	3.52634E-02	7.05317E-03	4.17835E-03	5.40527E-03
54XE133 1	4.34647E-05	1.38348E-03	0.	4.68374E-04	2.69174E-04

53 I134 0	1.49854E-05	2.91702E-02	3.95562E-02	1.09843E-01	7.99500E-02
53 I135 0	1.16209E-04	3.00626E-02	2.32661E-02	6.36842E-02	4.64943E-02
54XE135 0	5.12704E-05	9.52473E-03	5.92293E-03	3.62286E-03	4.55004E-03
54XE135 1	6.97992E-07	4.66297E-03	0.	3.57411E-03	2.05404E-03
54XE138 0	2.39265E-07	1.72224E-03	2.22695E-03	2.99452E-03	2.66807E-03
TOTAL GAS	2.16419E+02	9.20610E+09	1.62749E-01	4.69254E-01	6.32002E-01
	1.34429E+01	(RADIOACTIVE GAS DENSITY)			
TOTAL FP	1.39000E+03	4.24404E+09	9.65906E-01	1.30642E+00	2.27323E+00
TOTAL GAS FRACTIONS	1.55697E-01	2.16914E-01	1.68336E-01	3.59191E-01	2.78020E-01
	9.67117E-03	(RADIOACTIVE FRACTION OF TOTAL FP)			
NOBLE GAS FRACTIONS	1.48412E-01	9.08997E-02	4.25199E-02	6.76202E-02	5.69445E-02
	4.03583E-03	(NOBLE RADIOACTIVE GAS FRACTION OF TOTAL FP)			

TABLE C-Y

TMI, UNIT 2. 22-STEP POWER HISTORY. FULL CORE CALC., CINDER-10(LASL) 7/79

CONTENT OF NOBLE GASES AND HALOGENS
(EXCEPTING 1.00000E-02 PERCENT OF TOTAL GAS)

TIME STEP 31
 ELAPSED TIME=2.93450E+07 SEC
 COOLING TIME=7.20000E+03 SEC
 TOTAL ACTIVITY=1.36500E+20
 CURIES IN ALL FP= 3.69918E+09
 IN ALL GAS= 9.13790E+08
 IN HALOGENS= 5.02752E+08
 IN NOBLE GAS= 3.11728E+08
 TOTAL BETA MEV/FISS=7.49429E-01
 TOTAL GAMMA MEV/FISS=9.99050E-01
 TOTAL BETA+GAMMA=1.76948E+00
 FRACTION OF TOTALS IN GAS PRODUCTS
 BETA FRACTION=1.69912E-01
 GAMMA FRACTION=3.77268E-01
 TOTAL FRACTION=2.97051E-01
 FRACTIONAL DENSITY ALL GAS=1.55697E-01
 DENSITY OF RADIOACTIVE GAS=9.63623E-03
 FRACTIONAL GAS ACTIVITY=2.20585E-01

DECAY POWER IN MW FOR ALL FP IS
 TOTAL BETA MW=1.01895E+01
 TOTAL GAMMA MW=1.32290E+01
 TOTAL BETA+GAMMA MW=2.34175E+01
 (MULTIPLY MEV/F BY 1.32416E+01 TO GET MW)

TABULAR VALUES ARE GIVEN AS FRACTIONS OF ALL NUCLIDES

NUCLIDE	DENSITY	CURIES	BETA MEV/F	GAMMA MEV/F	B+G MEV/F
Z A S					
35SR 83 0	2.21555E-06	1.80999E-03	1.25871E-03	2.18416E-05	5.59977E-04
36KR 83 1	2.51311E-06	2.64915E-03	0.	1.83049E-04	1.03408E-04
35SR 84 0	1.23979E-07	4.58646E-04	1.23619E-03	1.32986E-03	1.28954E-03

36KR 85 1	1.18624E-05	5.19161E-03	2.51923E-03	1.57239E-03	1.99434E-03
36KR 87 0	3.03868E-06	4.70359E-03	1.34726E-02	6.16265E-03	9.34305E-03
36KR 89 0	1.71696E-05	1.70729E-02	5.41476E-03	4.39587E-02	2.76241E-02
53 I131 0	1.70096E-03	1.72815E-02	6.89766E-03	1.11206E-02	9.27591E-03
53 I132 0	3.09017E-05	2.64299E-02	2.97542E-02	9.77647E-02	6.81791E-02
53 I133 0	4.15859E-04	3.92772E-02	3.51007E-02	3.88086E-02	3.71954E-02
54XE133 0	2.62801E-03	4.05939E-02	9.87455E-03	5.46357E-03	6.94762E-03
54XE133 1	4.34355E-05	1.59124E-03	0.	6.12066E-04	3.45769E-04
53 I134 0	8.90370E-04	1.99133E-02	2.95312E-02	8.53423E-02	6.10600E-02
53 I135 0	1.04598E-04	3.11435E-02	2.63137E-02	7.49573E-02	5.37934E-02
54XE135 0	5.87744E-05	1.25449E-02	9.35874E-03	5.43087E-03	6.70473E-03
54XE135 1	6.20726E-07	4.77272E-03	0.	4.15637E-03	2.34802E-03
54XE138 0	1.27915E-08	1.05977E-04	1.49597E-04	2.09346E-04	1.83350E-04
TOTAL GAS	2.16407E+02	9.13799E+08	1.30735E-01	3.76909E-01	5.07644E-01
	1.33944E+01	(RADIOACTIVE GAS DENSITY)			
TOTAL FP	1.39000E+03	3.68918E+09	7.69429E-01	9.99050E-01	1.76848E+00
TOTAL GAS FRACTIONS	1.55689E-01	2.20595E-01	1.69912E-01	3.77268E-01	2.87051E-01
	9.63623E-03	(RADIOACTIVE FRACTION OF TOTAL FP)			
NOBLE GAS FRACTIONS	1.48436E-01	8.43081E-02	3.98035E-02	6.77751E-02	5.56053E-02
	4.03400E-03	(NOBLE RADIOACTIVE GAS FRACTION OF TOTAL FP)			

TABLE C-XI

TMI, UNIT 2, 22-STEP POWER HISTORY, FULL CORE CALC., CINDEP-10(LASL) 7/79

CONTENT OF NOBLE GASES AND HALOGENS
(EXCEEDING 1.00000E-02 PERCENT OF TOTAL GAS)

TIME STEP 32
 ELAPSED TIME=2.93558E+07 SEC
 COOLING TIME=1.80000E+04 SEC
 TOTAL ACTIVITY=1.13087E+20
 CURIES IN ALL FP= 3.05441E+09
 IN ALL GAS= 6.55247E+09
 IN HALOGENS= 3.87166E+09
 IN NOBLE GAS= 2.59981E+09
 TOTAL BETA MEV/FISS=5.61617E-01
 TOTAL GAMMA MEV/FISS=7.01234E-01
 TOTAL BETA+GAMMA=1.26295E+00
 FRACTION OF TOTALS IN GAS PRODUCTS
 BETA FRACTION=1.61867E-01
 GAMMA FRACTION=3.53094E-01
 TOTAL FRACTION=2.68965E-01
 FRACTIONAL DENSITY ALL GAS=1.55654E-01
 DENSITY OF RADIOACTIVE GAS=9.54271E-03
 FRACTIONAL GAS ACTIVITY=2.14395E-01

DECAY POWER IN MW FOR ALL FP IS
 TOTAL BETA MW=7.43671E+00
 TOTAL GAMMA MW=9.28546E+00
 TOTAL BETA+GAMMA MW=1.67222E+01
 (MULTIPLY MEV/F BY 1.32415E+01 TO GET MW)

TABULAR VALUES ARE GIVEN AS FRACTIONS OF ALL NUCLIDES

NUCLIDE	DENSITY	CURIES	BETA MEV/F	GAMMA MEV/F	B+G MEV/F
Z A S					
359R 93 0	9.34165E-07	9.21164E-04	7.27103E-04	1.31205E-05	3.30644E-04
36KR 85 1	7.45746E-06	3.93948E-03	2.16977E-03	1.40832E-03	1.74695E-03
36KR 87 0	5.98462E-07	1.09947E-03	3.57444E-03	1.70030E-03	2.53379E-03
36KR 89 0	8.17012E-06	6.90552E-03	4.19192E-03	2.98014E-02	1.84079E-02
53 I131 0	1.68555E-03	2.06704E-02	9.34128E-03	1.57001E-02	1.28722E-02
53 I132 0	3.02197E-05	3.12289E-02	4.07079E-02	1.36654E-01	9.36728E-02
53 I133 0	3.77866E-04	4.29932E-02	4.36955E-02	5.02394E-02	4.73292E-02
54XE133 0	2.62516E-03	4.89328E-02	1.21451E-02	7.77550E-03	9.71877E-03
54XE133 1	4.32551E-05	1.91270E-03	0.	8.68389E-04	4.82198E-04
53 I134 0	1.23160E-05	3.32478E-03	5.59642E-03	1.68186E-02	1.18279E-02
53 I135 0	7.62745E-05	2.74122E-02	2.62984E-02	7.78746E-02	5.49332E-02
54XE135 0	7.21618E-05	1.86237E-02	1.40601E-02	9.49976E-03	1.15279E-02
54XE135 1	4.52211E-07	4.19688E-03	0.	4.31399E-03	2.39547E-03
TOTAL GAS	2.16359E+02	6.55247E+08	9.09074E-02	2.47595E-01	3.38502E-01
	1.32544E+01	(RADIODACTIVE GAS DENSITY)			
TOTAL FP	1.39000E+03	3.05641E+09	5.61617E-01	7.01234E-01	1.26285E+00
TOTAL GAS FRACTIONS	1.55654E-01	2.14385E-01	1.41867E-01	3.53084E-01	2.68046E-01
	9.54271E-03	(RADIODACTIVE FRACTION OF TOTAL FP)			
NOBLE GAS FRACTIONS	1.48488E-01	9.77112E-02	3.61507E-02	5.55645E-02	4.69307E-02
	4.02826E-03	(NOBLE RADIODACTIVE GAS FRACTION OF TOTAL FP)			

TABLE C-VII

TMI, UNIT 2, 22-STEP POWER HISTORY, FULL CORE CALC., CINDER-10(LASL) 7/79

CONTENT OF NOBLE GASES AND HALOGENS
(EXCEEDING 1.00000E-02 PERCENT OF TOTAL GAS)

TIME STEP 33
 ELAPSED TIME=2.93738E+07 SEC
 COOLING TIME=3.60000E+04 SEC
 TOTAL ACTIVITY=9.59714E+19
 CURIES IN ALL FP= 2.59382E+07
 IN ALL GAS= 5.51608E+08
 IN HALOGENS= 3.15967E+09
 IN NOBLE GAS= 2.35741E+08
 TOTAL BETA MEV/FISS=4.22372E-01
 TOTAL GAMMA MEV/FISS=5.59211E-01
 TOTAL BETA+GAMMA=9.81583E-01
 FRACTION OF TOTALS IN GAS PRODUCTS
 BETA FRACTION=1.72431E-01
 GAMMA FRACTION=3.33985E-01
 TOTAL FRACTION=2.54462E-01
 FRACTIONAL DENSITY ALL GAS=1.55598E-01
 DENSITY OF RADIODACTIVE GAS=9.40726E-03
 FRACTIONAL GAS ACTIVITY=2.12662E-01

DECAY POWER IN MW FOR ALL FP IS
TOTAL BETA MW=5.59289E+00

TOTAL GAMMA MW=7.40494E+00
TOTAL BETA+GAMMA MW=1.29977E+01
(MULTIPLY MEV/F BY 1.32616E+01 TO GET MW)

TABULAR VALUES ARE GIVEN AS FRACTIONS OF ALL NUCLIDES

NUCLIDE	DENSITY	CURIES	BETA MEV/F	GAMMA MEV/F	B+G MEV/F
Z A S					
35SR 83 0	2.20439E-07	2.56139E-04	2.29143E-04	3.88243E-06	1.00381E-04
36KR 85 1	3.44048E-06	2.14160E-03	1.33103E-03	8.14737E-04	1.03690E-03
36KR 87 0	3.81454E-08	9.39900E-05	3.79093E-04	1.38209E-04	2.11310E-04
36KR 89 0	2.36959E-06	2.36000E-03	1.61275E-03	1.08385E-02	6.86869E-03
53 I131 0	1.65905E-03	2.39739E-02	1.22256E-02	1.93779E-02	1.63003E-02
53 I132 0	2.90249E-05	3.54226E-02	5.10931E-02	1.64584E-01	1.15750E-01
53 I133 0	3.20040E-04	4.29990E-02	4.92095E-02	5.33579E-02	5.15729E-02
54XE133 0	2.61271E-03	5.73861E-02	1.60725E-02	9.70401E-03	1.24443E-02
54XE133 1	4.26700E-05	2.22333E-03	0.	1.07421E-03	6.11979E-04
53 I134 0	2.95616E-08	9.40354E-05	1.78613E-04	5.06213E-04	3.65248E-04
53 I135 0	4.50619E-05	1.90820E-02	2.05511E-02	5.76916E-02	4.17532E-02
54XE135 0	7.51339E-05	2.29505E-02	1.94666E-02	1.24039E-02	1.54429E-02
54XE135 1	2.67160E-07	2.92154E-03	0.	3.19592E-03	1.82073E-03
TOTAL GAS	2.16292E+02	5.51609E+09	7.29299E-02	1.86768E-01	2.59598E-01
	1.30761E+01	(RADIOACTIVE GAS DENSITY)			
TOTAL FP	1.39000E+03	2.59382E+09	4.22372E-01	5.59211E-01	9.81583E-01
TOTAL GAS FRACTIONS	1.55598E-01	2.12662E-01	1.72431E-01	3.33985E-01	2.64469E-01
	9.40726E-03	(RADIOACTIVE FRACTION OF TOTAL FP)			
NOBLE GAS FRACTIONS	1.48545E-01	9.09857E-02	3.89166E-02	3.82811E-02	3.85115E-02
	4.00743E-03	(NOBLE RADIOACTIVE GAS FRACTION OF TOTAL FP)			

TABLE C-XTII

TMI, UNIT 2, 22-STEP POWER HISTORY, FULL CORE CALC., CINDER-10(LASL) 7/79

CONTENT OF NOBLE GASES AND HALOGENS
(EXCEEDING 1.00000E-02 PERCENT OF TOTAL GAS)

TIME STEP 34
ELAPSED TIME=2.94009E+07 SEC
COOLING TIME=7.20000E+04 SEC
TOTAL ACTIVITY=7.90342E+19
CURIES IN ALL FP= 2.13606E+09
IN ALL GAS= 4.41153E+09
IN HALOGENS= 2.41504E+08
IN NOBLE GAS= 1.92649E+08
TOTAL BETA MEV/FISS=3.05970E-01
TOTAL GAMMA MEV/FISS=4.50542E-01
TOTAL BETA+GAMMA=7.56512E-01
FRACTION OF TOTALS IN GAS PRODUCTS
BETA FRACTION=1.91559E-01
GAMMA FRACTION=3.10100E-01
TOTAL FRACTION=2.58111E-01

FRACTIONAL DENSITY ALL GAS=1.55499E-01
 DENSITY OF RADIOACTIVE GAS=9.16092E-03

FRACTIONAL GAS ACTIVITY=2.06526E-01

DECAY POWER IN MW FP ALL FP IS
 TOTAL BETA MW=4.05154E+00
 TOTAL GAMMA MW=5.74590E+00
 TOTAL BETA+GAMMA MW=1.00174E+01
 (MULTIPLY MEV/F BY 1.32416E+01 TO GET MW)

TABULAR VALUES ARE GIVEN AS FRACTIONS OF ALL NUCLIDES

NUCLIDE			DENSITY	CURIES	BETA MEV/F	GAMMA MEV/F	B+G MEV/F
Z	A	S					
36	89	1	7.32280E-07	5.53505E-04	3.91076E-04	2.15237E-04	2.86355E-04
36	89	0	1.99327E-07	2.41063E-04	1.87272E-04	1.13162E-03	7.49691E-04
53	131	0	1.60635E-03	2.91966E-02	1.63404E-02	2.32877E-02	2.04779E-02
53	132	0	2.65874E-05	3.94015E-02	6.46077E-02	1.87127E-01	1.37574E-01
53	133	0	2.29343E-04	3.73374E-02	4.85794E-02	4.74592E-02	4.79527E-02
54	133	0	2.56465E-03	6.94021E-02	2.17789E-02	1.18230E-02	1.58497E-02
54	133	1	4.06992E-05	2.57509E-03	0.	1.27172E-03	7.57374E-04
53	135	0	1.57278E-05	8.09791E-03	9.94999E-03	2.49927E-02	1.89097E-02
54	135	0	5.46506E-05	2.01814E-02	1.95450E-02	1.11977E-02	1.45738E-02
54	135	1	9.32461E-08	1.23826E-03	0.	1.38451E-03	8.24549E-04
TOTAL GAS			2.16143E+02	4.41153E+08	5.55513E-02	1.39713E-01	1.95264E-01
			1.27337E+01	(RADIOACTIVE GAS DENSITY)			
TOTAL FP			1.39000E+03	2.13606E+09	3.05970E-01	4.50542E-01	7.56512E-01
TOTAL GAS FRACTIONS			1.55499E-01	2.06526E-01	1.81558E-01	3.10100E-01	2.58111E-01
			9.16092E-03	(RADIOACTIVE FRACTION OF TOTAL FP)			
NOBLE GAS FRACTIONS			1.48613E-01	9.34656E-02	4.19395E-02	2.70885E-02	3.30950E-02
			3.93186E-03	(NOBLE RADIOACTIVE GAS FRACTION OF TOTAL FP)			

TABLE C-XIV

TMI, UNIT 2, 22-STEP POWER HISTORY, FULL CORE CALC., CINDER-10(LASL) 7/79

CONTENT OF NOBLE GASES AND HALOGENS
 (EXCEEDING 1.00000E-02 PERCENT OF TOTAL GAS)

TIME STEP 35
 ELAPSED TIME=2.95178E+07 SEC
 COOLING TIME=1.90000E+05 SEC
 TOTAL ACTIVITY=5.90702E+19
 CURIES IN ALL FP= 1.59649E+09
 IN ALL GAS= 2.93163E+08
 IN HALOGENS= 1.49035E+09
 IN NOBLE GAS= 1.44128E+08
 TOTAL BETA MEV/FISS=7.05996E-01
 TOTAL GAMMA MEV/FISS=7.34879E-01
 TOTAL BETA+GAMMA=5.40866E-01
 FRACTION OF TOTALS IN GAS PRODUCTS
 BETA FRACTION=1.56938E-01

GAMMA FRACTION=2.64569E-01
 TOTAL FRACTION=2.23540E-01

FRACTIONAL DENSITY ALL GAS=1.55272E-01
 DENSITY OF RADIOACTIVE GAS=3.54867E-03
 FRACTIONAL GAS ACTIVITY=1.83630E-01

DECAY POWER IN MW FOR ALL FP IS
 TOTAL BETA MW=2.72759E+00
 TOTAL GAMMA MW=4.43436E+00
 TOTAL BETA+GAMMA MW=7.16193E+00
 (MULTIPLY MEV/F BY 1.32416E+01 TO GET MW)

TABULAR VALUES ARE GIVEN AS FRACTIONS OF ALL NUCLIDES

NUCLIDE	DENSITY	CURIES	BETA MEV/F	GAMMA MEV/F	B+G MEV/F
Z A S					
53 I131 0	1.45301E-03	3.41131E-02	2.19552E-02	2.83403E-02	2.59085E-02
53 I132 0	2.03657E-05	4.03836E-02	7.35142E-02	1.92854E-01	1.47404E-01
53 I133 0	8.43931E-05	1.83823E-02	2.65079E-02	2.34957E-02	2.46809E-02
54XE133 0	2.31820E-03	9.27254E-02	2.92415E-02	1.43780E-02	2.00387E-02
54XE133 1	3.20043E-05	2.70933E-03	0.	1.34543E-03	8.33027E-04
53 I135 0	6.68725E-07	4.60104E-04	6.28405E-04	1.42968E-03	1.12452E-03
54XE135 0	9.08101E-06	4.48691E-03	4.82411E-03	2.50331E-03	3.38718E-03
TOTAL GAS	2.15823E+02	2.93163E+08	3.23065E-02	8.85986E-02	1.20905E-01
	1.18827E+01	(RADIOACTIVE GAS DENSITY)			
TOTAL FP	1.39000E+03	1.59649E+09	2.05986E-01	3.34879E-01	5.40866E-01
TOTAL GAS FRACTIONS	1.55272E-01	1.83630E-01	1.56839E-01	2.64569E-01	2.23540E-01
	3.54867E-03	(RADIOACTIVE FRACTION OF TOTAL FP)			
NOBLE GAS FRACTIONS	1.48688E-01	9.02779E-02	3.41240E-02	1.83878E-02	2.43809E-02
	3.62996E-03	(NOBLE RADIOACTIVE GAS FRACTION OF TOTAL FP)			

TABLE C-XV

TMI, UNIT 2, 22-STEP POWER HISTORY, FULL CORE CALC., CINDER-10(LASL) 7/79

CONTENT OF NOBLE GASES AND HALOGENS
 (EXCEEDING 1.00000E-02 PERCENT OF TOTAL GAS)

TIME STEP 36
 ELAPSED TIME=2.96978E+07 SEC
 COOLING TIME=3.60000E+05 SEC
 TOTAL ACTIVITY=4.66281E+12
 CURIES IN ALL FP= 1.25022E+09
 IN ALL GAS= 2.00311E+08
 IN HALOGENS= 9.25675E+07
 IN NOBLE GAS= 1.07641E+08
 TOTAL BETA MEV/FISS=1.59870E-01
 TOTAL GAMMA MEV/FISS=2.63655E-01
 TOTAL BETA+GAMMA=4.23525E-01
 FRACTION OF TOTALS IN GAS PRODUCTS
 BETA FRACTION=1.21051E-01
 GAMMA FRACTION=2.08622E-01

TOTAL FRACTION=1.75566E-01
 FRACTIONAL DENSITY ALL GAS=1.54971E-01

DENSITY OF RADIOACTIVE GAS=7.74794E-03
 FRACTIONAL GAS ACTIVITY=1.59949E-01

DECAY POWER IN MW FOR ALL FP IS
 TOTAL BETA MW=2.11493E+00
 TOTAL GAMMA MW=3.49121E+00
 TOTAL BETA+GAMMA MW=5.60615E+00
 (MULTIPLY MEV/F BY 1.32416E+01 TO GET MW)

TABULAR VALUES ARE GIVEN AS FRACTIONS OF ALL NUCLIDES

NUCLIDE	DENSITY	CURIES	BETA MEV/F	GAMMA MEV/F	B+G MEV/F
Z A S					
53 I131 0	1.22120E-03	3.63211E-02	2.37753E-02	3.02534E-02	2.78080E-02
53 I132 0	1.30632E-05	3.28762E-02	5.07377E-02	1.57076E-01	1.20712E-01
53 I133 0	1.59469E-05	4.40052E-03	6.47814E-03	5.63912E-03	5.95583E-03
54XE133 0	1.83435E-03	8.29241E-02	2.98129E-02	1.44505E-02	2.02494E-02
54XE133 1	1.84977E-05	1.78379E-03	0.	9.87696E-04	6.14866E-04
54XE135 0	2.49451E-07	1.56139E-04	1.70742E-04	8.73411E-05	1.18823E-04
TOTAL GAS	2.15410E+02 1.07695E+01 (RADIOACTIVE GAS DENSITY)	2.00311E+08	1.93523E-02	5.50042E-02	7.43565E-02
TOTAL FP	1.39000E+03	1.26022E+09	1.59970E-01	2.63655E-01	4.23525E-01
TOTAL GAS FRACTIONS	1.54971E-01 7.74794E-03 (RADIOACTIVE FRACTION OF TOTAL FP)	1.59949E-01	1.21051E-01	2.08622E-01	1.75566E-01
NOBLE GAS FRACTIONS	1.48671E-01 3.12308E-03 (NOBLE RADIOACTIVE GAS FRACTION OF TOTAL FP)	8.54149E-02	3.00513E-02	1.56238E-02	2.10698E-02

TABLE C-XVI

TMI, UNIT 2, 22-STEP POWER HISTORY, FULL CORE CALC., CINDER-10(LASL) 7/79

CONTENT OF NOBLE GASES AND HALOGENS
 (EXCEPTING 1.00000E-02 PERCENT OF TOTAL GAS)

TIME STEP 37
 ELAPSED TIME=3.00579E+07 SEC
 COOLING TIME=7.20000E+05 SEC
 TOTAL ACTIVITY=3.54130E+19
 CURIES IN ALL FP= 9.57109E+09
 IN ALL GAS= 1.12071E+09
 IN HALOGENS= 4.02555E+07
 IN NOBLE GAS= 6.28153E+07
 TOTAL BETA MEV/FISS=1.24099E-01
 TOTAL GAMMA MEV/FISS=1.95620E-01
 TOTAL BETA+GAMMA=3.19720E-01
 FRACTION OF TOTALS IN GAS PRODUCTS
 BETA FRACTION=7.66977E-02
 GAMMA FRACTION=1.27884E-01
 TOTAL FRACTION=1.08014E-01
 FRACTIONAL DENSITY ALL GAS=1.54487E-01

DENSITY OF RADIOACTIVE GAS=6.61871E-03
 FRACTIONAL GAS ACTIVITY=1.17093E-01

DECAY POWER IN MW FOR ALL FP IS
 TOTAL BETA MW=1.54313E+00
 TOTAL GAMMA MW=2.59033E+00
 TOTAL BETA+GAMMA MW=4.23346E+00
 (MULTIPLY MEV/F BY 1.32416E+01 TO GET MW)

TABULAR VALUES ARE GIVEN AS FRACTIONS OF ALL NUCLIDES

NUCLIDE	DENSITY	CURIES	BETA MEV/F	GAMMA MEV/F	B+G MEV/F
Z A S					
53 I131 0	8.55257E-04	3.34929E-02	2.14521E-02	2.85565E-02	2.57991E-02
53 I132 0	5.37046E-04	1.77623E-02	3.21797E-02	8.70546E-02	6.57557E-02
53 I133 0	5.69398E-07	2.06884E-04	2.99004E-04	2.71376E-04	2.81712E-04
54XE133 0	1.08273E-03	6.44484E-02	2.24712E-02	1.14958E-02	1.58333E-02
54XE133 1	5.30132E-04	7.48589E-04	0.	3.81514E-04	2.33437E-04
TOTAL GAS	2.14738E+02	1.12071E+08	9.51605E-03	2.50171E-02	3.45331E-02
	9.20001E+00	(RADIOACTIVE GAS DENSITY)			
TOTAL FP	1.39000E+03	9.57109E+08	1.24099E-01	1.95620E-01	3.19709E-01
TOTAL GAS FRACTIONS	1.54487E-01	1.17093E-01	7.66877E-02	1.27886E-01	1.08014E-01
	6.61871E-03	(RADIOACTIVE FRACTION OF TOTAL FP)			
NOBLE GAS FRACTIONS	1.48536E-01	6.56302E-02	2.27584E-02	1.19998E-02	1.61756E-02
	2.35612E-03	(NOBLE RADIOACTIVE GAS FRACTION OF TOTAL FP)			

TABLE C-XVII

THI, UNIT 2, 22-STEP POWER HISTORY, FULL CORE CALC., CINDER-10(LASL) 7/79

CONTENT OF NOBLE GASES AND HALOGENS
 (EXCEEDING 1.00000E-02 PERCENT OF TOTAL GAS)

TIME STEP 38
 ELAPSED TIME=3.11378E+07 SEC
 COOLING TIME=1.30000E+06 SEC
 TOTAL ACTIVITY=2.24734E+19
 CURIES IN ALL FP= 5.07389E+09
 IN ALL GAS= 2.45126E+07
 IN HALOGENS= 1.21006E+07
 IN NOBLE GAS= 1.24120E+07
 TOTAL BETA MEV/FISS=8.10989E-02
 TOTAL GAMMA MEV/FISS=1.11905E-01
 TOTAL BETA+GAMMA=1.93095E-01
 FRACTION OF TOTALS IN GAS PRODUCTS
 BETA FRACTION=2.15356E-02
 GAMMA FRACTION=3.16783E-02
 TOTAL FRACTION=2.74155E-02
 FRACTIONAL DENSITY ALL GAS=1.53357E-01
 DENSITY OF RADIOACTIVE GAS=5.23441E-03
 FRACTIONAL GAS ACTIVITY=4.03573E-02

DECAY POWER IN MW FPD ALL FP IS

TOTAL BETA MW=1.07388E+00
 TOTAL GAMMA MW=1.48182E+00
 TOTAL BETA+GAMMA MW=2.55570E+00
 (MULTIPLY MEV/F BY 1.32416E+01 TO GET MW)

TABULAR VALUES ARE GIVEN AS FRACTIONS OF ALL NUCLIDES

NUCLIDE	DENSITY	CURIES	BETA MEV/F	GAMMA MEV/F	B+G MEV/F
Z A S					
53 I131 0	2.91304E-04	1.79742E-02	1.11798E-02	1.70026E-02	1.45559E-02
53 I132 0	3.73415E-07	1.04614E-03	3.47345E-03	1.05811E-02	7.57354E-03
54Xe133 0	2.12215E-04	1.99051E-02	6.79905E-03	3.93875E-03	5.14062E-03
TOTAL GAS	2.13861E+02 7.27583E+00 (RADIOACTIVE GAS DENSITY)	2.45174E+07	1.74651E-03	3.54500E-03	5.29151E-03
TOTAL FP	1.39000E+02	6.07399E+08	9.10989E-02	1.11906E-01	1.93005E-01
TOTAL GAS FRACTIONS	1.53957E-01 5.23441E-03 (RADIOACTIVE FRACTION OF TOTAL FP)	4.03573E-02	2.15354E-02	3.16783E-02	2.74165E-02
NOBLE GAS FRACTIONS	1.48392E-01 1.47333E-03 (NOBLE RADIOACTIVE GAS FRACTION OF TOTAL FP)	2.04349E-02	6.93230E-03	4.09457E-03	5.28694E-03

TABLE C-VVIII

TMI, UNIT 2, 22-STEP POWER HISTORY, FULL CORE CALC., CINDER-10(LASL) 7/79

CONTENT OF NOBLE GASES AND HALOGENS
 (EXCEEDING 1.00000E-02 PERCENT OF TOTAL GAS)

TIME STEP 39
 ELAPSED TIME=3.29379E+07 SEC
 COOLING TIME=3.60007E+06 SEC
 TOTAL ACTIVITY=1.46129E+19
 CURIES IN ALL FP= 2.94940E+08
 IN ALL GAS= 2.79250E+06
 IN HALOGENS= 1.82619E+06
 IN NOBLE GAS= 9.46321E+05
 TOTAL BETA MEV/FISS=5.29149E-02
 TOTAL GAMMA MEV/FISS=6.35475E-02
 TOTAL BETA+GAMMA=1.16562E-01
 FRACTION OF TOTALS IN GAS PRODUCTS
 BETA FRACTION=3.78950E-03
 GAMMA FRACTION=5.72967E-03
 TOTAL FRACTION=4.94895E-03
 FRACTIONAL DENSITY ALL GAS=1.53757E-01
 DENSITY OF RADIOACTIVE GAS=4.86341E-03
 FRACTIONAL GAS ACTIVITY=7.07069E-03

DECAY POWER IN MW FPD ALL FP IS
 TOTAL BETA MW=7.00670E-01
 TOTAL GAMMA MW=9.42795E-01
 TOTAL BETA+GAMMA MW=1.54347E+00
 (MULTIPLY MEV/F BY 1.32416E+01 TO GET MW)

TABULAR VALUES ARE GIVEN AS FRACTIONS OF ALL NUCLIDES

NUCLIDE	DENSITY	CURIES	BETA MEV/F	GAMMA MEV/F	B+G MEV/F
Z A S					
53 I131 0	4.83513E-05	4.59874E-03	2.84402E-03	4.96190E-03	4.00047E-03
53 I132 0	4.39027E-09	3.51992E-05	6.15978E-05	2.18728E-04	1.47438E-04
54XE133 0	1.38568E-05	1.99997E-03	6.90409E-04	4.52185E-04	5.55790E-04
TOTAL GAS	2.13722E+02 6.76012E+00 (RADIOACTIVE GAS DENSITY)	2.79250E+06	2.00526E-04	3.64679E-04	5.65205E-04
TOTAL FP	1.39000E+03	3.94940E+03	5.29149E-02	6.36475E-02	1.16562E-01
TOTAL GAS FRACTIONS	1.53757E-01 4.36341E-03 (RADIOACTIVE FRACTION OF TOTAL FP)	7.07069E-03	3.79259E-03	5.72967E-03	4.84895E-03
NOBLE GAS FRACTIONS	1.48444E-01 1.26515E-03 (NOBLE RADIOACTIVE GAS FRACTION OF TOTAL FP)	2.44675E-03	9.83977E-04	5.49039E-04	7.01043E-04

TABLE C-VIX

TMI, UNIT 2, 22-STEP POWER HISTORY, FULL CORE CALC., CINDER-10(LASL) 7/79

CONTENT OF NOBLE GASES AND HALOGENS
(EXCEEDING 1.00000E-02 PERCENT OF TOTAL GAS)

TIME STEP 40
 ELAPSED TIME=3.65379E+07 SEC
 COOLING TIME=7.20000E+06 SEC
 TOTAL ACTIVITY=8.49797E+18
 CURIES IN ALL FP= 2.29675E+03
 IN ALL GAS= 1.57207E+05
 IN HALOGENS= 4.99302E+04
 IN NOBLE GAS= 1.07276E+05
 TOTAL BETA MEV/FISS=3.20401E-02
 TOTAL GAMMA MEV/FISS=3.39143E-02
 TOTAL BETA+GAMMA=6.59543E-02
 FRACTION OF TOTALS IN GAS PRODUCTS
 BETA FRACTION=4.67764E-04
 GAMMA FRACTION=2.82135E-04
 TOTAL FRACTION=3.72312E-04
 FRACTIONAL DENSITY ALL GAS=1.53937E-01
 DENSITY OF RADIOACTIVE GAS=4.87676E-03
 FRACTIONAL GAS ACTIVITY=6.84675E-04

DECAY POWER IN MW FOR ALL FP IS
 TOTAL BETA MW=4.24262E-01
 TOTAL GAMMA MW=4.49080E-01
 TOTAL BETA+GAMMA MW=8.73342E-01
 (MULTIPLY MEV/F BY 1.32416E+01 TO GET MW)

TABULAR VALUES ARE GIVEN AS FRACTIONS OF ALL NUCLIDES

NUCLIDE	DENSITY	CURIES	BETA MEV/F	GAMMA MEV/F	B+G MEV/F
---------	---------	--------	------------	-------------	-----------

Z	A	S					
36KR	85	0	1.23891E-03	4.14815E-04	3.33564E-04	2.80436E-06	1.63486E-04
53	1131	0	1.33208E-06	7.17386E-04	1.29401E-04	2.56547E-04	1.94781E-04
TOTAL GAS			2.13833E+02	1.57207E+05	1.49872E-05	9.56841E-06	2.45556E-05
			6.77866E+00	(RADIOACTIVE GAS DENSITY)			
TOTAL FP			1.38999E+03	7.29675E+08	3.20401E-02	3.39143E-02	6.59543E-02
TOTAL GAS FRACTIONS			1.53837E-01	6.84475E-04	4.67764E-04	2.82135E-04	3.72312E-04
			4.87676E-03	(RADIOACTIVE FRACTION OF TOTAL FP)			
NOBLE GAS FRACTIONS			1.48469E-01	4.67079E-04	3.38349E-04	2.55310E-05	1.77495E-04
			1.23931E-03	(NOBLE RADIOACTIVE GAS FRACTION OF TOTAL FP)			

TABLE C-XX

TMI, UNIT 2, 22-STEP POWER HISTORY, FULL CORE CALC., CINDER-10(LASL) 7/79

CONTENT OF NOBLE GASES AND HALOGENS
(EXCEEDING 1.00000E-02 PERCENT OF TOTAL GAS)

TIME STEP 41
 ELAPSED TIME=4.73378E+07 SEC
 COOLING TIME=1.80000E+07 SEC
 TOTAL ACTIVITY=2.93655E+18
 CURIES IN ALL FP= 7.93662E+07
 IN ALL GAS= 9.31976E+04
 IN HALOGENS= 1.23586E+00
 IN NOBLE GAS= 9.31964E+04
 TOTAL BETA MEV/FISS=1.41514E-02
 TOTAL GAMMA MEV/FISS=9.96273E-03
 TOTAL BETA+GAMMA=2.41142E-02
 FRACTION OF TOTALS IN GAS PRODUCTS
 BETA FRACTION=7.38715E-04
 GAMMA FRACTION=9.40677E-06
 TOTAL FRACTION=4.37403E-04
 FRACTIONAL DENSITY ALL GAS=1.53897E-01
 DENSITY OF RADIOACTIVE GAS=4.90599E-03
 FRACTIONAL GAS ACTIVITY=1.17427E-03

DECAY POWER IN MW FOR ALL FP IS
 TOTAL BETA MW=1.97398E-01
 TOTAL GAMMA MW=1.71923E-01
 TOTAL BETA+GAMMA MW=3.17311E-01
 (MULTIPLY MEV/F BY 1.32416E+01 TO GET MW)

TABULAR VALUES ARE GIVEN AS FRACTIONS OF ALL NUCLIDES

NUCLIDE	DENSITY	CURIES	BETA MEV/F	GAMMA MEV/F	B+G MEV/F		
Z	A	S					
36KR	85	0	1.21183E-03	1.17417E-03	7.38709E-04	9.33763E-06	4.37370E-04
TOTAL GAS			2.13915E+02	9.31976E+04	1.04539E-05	9.37172E-08	1.05476E-05
			6.81927E+00	(RADIOACTIVE GAS DENSITY)			
TOTAL FP			1.38999E+03	7.93662E+07	1.41514E-02	9.96273E-03	2.41142E-02

TOTAL GAS
 FRACTIONS 1.53897E-01 1.17427E-03 7.39715E-04 9.40677E-06 4.37403E-04
 4.90599E-03 (RADIOACTIVE FRACTION OF TOTAL FP)

NOBLE GAS
 FRACTIONS 1.48444E-01 1.17425E-03 7.38709E-04 9.38816E-06 4.37391E-04
 1.21193E-03 (NOBLE RADIOACTIVE GAS FRACTION OF TOTAL FP)

TABLE C-XXI

THI, UNIT 2, 22-STEP POWER HISTORY, FULL CORE CALC., CINDER-10(LASL) 7/79

CONTENT OF NOBLE GASES AND HALOGENS
 (EXCEEDING 1.00000E-02 PERCENT OF TOTAL GAS)

TIME STEP 42
 ELAPSED TIME=6.08738E+07 SEC
 COOLING TIME=3.15360E+07 SEC
 TOTAL ACTIVITY=1.31440E+19
 CURIES IN ALL FP= 3.55244E+07
 IN ALL GAS= 9.06432E+04
 IN HALOGENS= 1.92084E-01
 IN NOBLE GAS= 9.06430E+04
 TOTAL BETA MEV/FISS=7.96629E-03
 TOTAL GAMMA MEV/FISS=2.48154E-03
 TOTAL BETA+GAMMA=1.04478E-02
 FRACTION OF TOTALS IN GAS PRODUCTS
 BETA FRACTION=1.27640E-03
 GAMMA FRACTION=3.64650E-05
 TOTAL FRACTION=9.81890E-04
 FRACTIONAL DENSITY ALL GAS=1.53894E-01
 DENSITY OF RADIOACTIVE GAS=4.87740E-03
 FRACTIONAL GAS ACTIVITY=2.55159E-03

DECAY POWER IN MW FOR ALL FP IS
 TOTAL BETA MW=1.05496E-01
 TOTAL GAMMA MW=3.28596E-02
 TOTAL BETA+GAMMA MW=1.38346E-01
 (MULTIPLY MEV/F BY 1.32416E+01 TO GET MW)

TABULAR VALUES ARE GIVEN AS FRACTIONS OF ALL NUCLIDES

NUCLIDE	DENSITY	CURIES	BETA MEV/F	GAMMA MEV/F	B+G MEV/F
Z A S					
36KR 85 0	1.17872E-03	2.55157E-03	1.27640E-03	3.64636E-05	9.81889E-04
TOTAL GAS	2.13996E+02	9.06432E+04	1.01691E-05	9.04895E-08	1.02596E-05
	6.77950E+00				(RADIOACTIVE GAS DENSITY)
TOTAL FP	1.38998E+03	3.55244E+07	7.96629E-03	2.48154E-03	1.04478E-02
TOTAL GAS FRACTIONS	1.53894E-01	2.55159E-03	1.27640E-03	3.64650E-05	9.81890E-04
	4.87740E-03				(RADIOACTIVE FRACTION OF TOTAL FP)

NOBLE GAS
FRACTIONS 1.48411E-01 2.55157E-03 1.27640E-03 3.64636E-05 9.81889E-04

1.17872E-03 (NOBLE RADIOACTIVE GAS FRACTION OF TOTAL FP)

TABLE C-XXII

TMI, UNIT 2, 22-STEP POWER HISTORY, FULL CORE CALC., CINDER-10(LASL) 7/79

CONTENT OF NOBLE GASES AND HALOGENS
(EXCEEDING 1.00000E-02 PERCENT OF TOTAL GAS)

TIME STEP 43
ELAPSED TIME=6.53378E+07 SEC
COOLING TIME=3.60000E+07 SEC
TOTAL ACTIVITY=1.10763E+18
CURIES IN ALL FP= 2.99009E+07
 IN ALL GAS= 8.99197E+04
 IN HALOGENS= 1.92099E-01
 IN NOBLE GAS= 9.99195E+04
TOTAL BETA MEV/FISS=6.92002E-03
TOTAL GAMMA MEV/FISS=1.68930E-03
TOTAL BETA+GAMMA=8.60932E-03
FRACTION OF TOTALS IN GAS PRODUCTS
 BETA FRACTION=1.45601E-03
 GAMMA FRACTION=5.30790E-05
 TOTAL FRACTION=1.18073E-03
 FRACTIONAL DENSITY ALL GAS=1.53876E-01
 DENSITY OF RADIOACTIVE GAS=4.96680E-03
 FRACTIONAL GAS ACTIVITY=3.01395E-03

DECAY POWER IN MW FOR ALL FP IS
 TOTAL BETA MW=9.15321E-02
 TOTAL GAMMA MW=2.23491E-02
 TOTAL BETA+GAMMA MW=1.14001E-01
(MULTIPLY MEV/F BY 1.32416E+01 TO GET MW)

TABULAR VALUES ARE GIVEN AS FRACTIONS OF ALL NUCLIDES

NUCLIDE	DENSITY	CURIES	BETA MEV/F	GAMMA MEV/F	B+G MEV/F
Z A S					
36KR 85 0	1.16799E-03	3.01395E-03	1.45601E-03	5.30769E-05	1.18073E-03
TOTAL GAS	2.13885E+02 6.76476E+00 (RADIOACTIVE GAS DENSITY)	8.99197E+04	1.00756E-05	8.96664E-08	1.01653E-05
TOTAL FP	1.38998E+03	2.99009E+07	6.92002E-03	1.68930E-03	8.60932E-03
TOTAL GAS FRACTIONS	1.53876E-01 4.96680E-03 (RADIOACTIVE FRACTION OF TOTAL FP)	3.01395E-03	1.45601E-03	5.30790E-05	1.18073E-03
NOBLE GAS FRACTIONS	1.48401E-01 1.16799E-03 (NOBLE RADIOACTIVE GAS FRACTION OF TOTAL FP)	3.01395E-03	1.45601E-03	5.30769E-05	1.18073E-03

TABLE C-XXIII

TMI, UNIT 2, 22-STEP POWER HISTORY, FULL CORE CALC., CINDER-10(LASL) 7/79

CONTENT OF NOBLE GASES AND HALOGENS
(EXCEEDING 1.00000E-02 PERCENT OF TOTAL GAS)

TIME STEP 44
 ELAPSED TIME=1.01339E+08 SEC
 COOLING TIME=7.20000E+07 SEC
 TOTAL ACTIVITY=4.67316E+17
 CURIES IN ALL FP= 1.24302E+07
 IN ALL GAS= 9.34378E+04
 IN HALOGENS= 1.92792E-01
 IN NOBLE GAS= 9.34376E+04
 TOTAL BETA MEV/FISS=2.79614E-03
 TOTAL GAMMA MEV/FISS=4.29909E-04
 TOTAL BETA+GAMMA=3.22604E-03
 FRACTION OF TOTALS IN GAS PRODUCTS
 BETA FRACTION=3.34742E-03
 GAMMA FRACTION=1.93754E-04
 TOTAL FRACTION=2.92715E-03
 FRACTIONAL DENSITY ALL GAS=1.53800E-01
 DENSITY OF RADIOACTIVE GAS=4.79393E-03
 FRACTIONAL GAS ACTIVITY=6.60622E-03

DECAY POWER IN MW FOR ALL FP IS
 TOTAL BETA MW=3.70252E-02
 TOTAL GAMMA MW=5.49269E-03
 TOTAL BETA+GAMMA MW=4.27190E-02
 (MULTIPLY MEV/F BY 1.32416E+01 TO GET MW)

TABULAR VALUES ARE GIVEN AS FRACTIONS OF ALL NUCLIDES

NUCLIDE	DENSITY	CURIES	BETA MEV/F	GAMMA MEV/F	B+G MEV/F
Z A S					
36KR 85 0	1.08503E-03	6.60621E-03	3.34742E-03	1.93746E-04	2.92715E-03
TOTAL GAS	2.13778E+02	9.34378E+04	9.35983E-06	8.32965E-08	9.44313E-06
	6.64951E+00	(RADIOACTIVE GAS DENSITY)			
TOTAL FP	1.38997E+03	1.26302E+07	2.79614E-03	4.29909E-04	3.22604E-03
TOTAL GAS FRACTIONS	1.53800E-01	6.60622E-03	3.34742E-03	1.93754E-04	2.92715E-03
	4.79393E-03	(RADIOACTIVE FRACTION OF TOTAL FP)			
NOBLE GAS FRACTIONS	1.48319E-01	6.60621E-03	3.34742E-03	1.93746E-04	2.92715E-03
	1.08503E-03	(NOBLE RADIOACTIVE GAS FRACTION OF TOTAL FP)			

TABLE C-XXIV

TMI, UNIT 2, 22-STEP POWER HISTORY, FULL CORE CALC., CINDER-10(LASL) 7/79

CONTENT OF NOBLE GASES AND HALOGENS
(EXCEEDING 1.00000E-02 PERCENT OF TOTAL GAS)

TIME STEP 45

ELAPSED TIME=2.09338E+08 SEC
 COOLING TIME=1.80000E+09 SEC
 TOTAL ACTIVITY=1.51657E+17
 CURIES IN ALL FP= 4.09864E+06
 IN ALL GAS= 5.6884E+04
 IN HALOGENS= 1.02092E-01
 IN NOBLE GAS= 5.6884E+04
 TOTAL BETA MEV/FISS=5.6886E-04
 TOTAL GAMMA MEV/FISS=2.35494E-04
 TOTAL BETA+GAMMA=8.04460E-04
 FRACTION OF TOTALS IN GAS PRODUCTS
 BETA FRACTION=1.31877E-02
 GAMMA FRACTION=2.83556E-04
 TOTAL FRACTION=9.41022E-03
 FRACTIONAL DENSITY ALL GAS=1.53589E-01
 DENSITY OF RADIOACTIVE GAS=4.56881E-03
 FRACTIONAL GAS ACTIVITY=1.63197E-02

DECAY POWER IN MW FOR ALL FP IS
 TOTAL BETA MW=7.53402E-03
 TOTAL GAMMA MW=9.11832E-03
 TOTAL BETA+GAMMA MW=1.06523E-02
 (MULTIPLY MEV/F BY 1.32416E+01 TO GET MW)

TABULAR VALUES ARE GIVEN AS FRACTIONS OF ALL NUCLIDES

NUCLIDE	DENSITY	CURIES	BETA MEV/F	GAMMA MEV/F	B+G MEV/F
Z A S					
36KR 85 0	8.69835E-04	1.63196E-02	1.31877E-02	2.83541E-04	9.41020E-03
TOTAL GAS	2.13479E+02 6.35038E+00 (RADIOACTIVE GAS DENSITY)	4.68884E+04	7.50337E-06	6.67758E-08	7.57014E-06
TOTAL FP	1.38994E+03	4.09864E+06	5.6886E-04	2.35494E-04	8.04460E-04
TOTAL GAS FRACTIONS	1.53589E-01 4.56881E-03 (RADIOACTIVE FRACTION OF TOTAL FP)	1.63197E-02	1.31877E-02	2.83556E-04	9.41022E-03
NOBLE GAS FRACTIONS	1.48107E-01 8.69835E-04 (NOBLE RADIOACTIVE GAS FRACTION OF TOTAL FP)	1.63196E-02	1.31877E-02	2.83541E-04	9.41020E-03

TABLE C-XXV

TMI, UNIT 2, 22-STEP POWER HISTORY, FULL CORE CALC., CINDER-10(LASL) 7/79

SUMMARY OF PROBLEM OUTPUT

POWER, TOTAL CONTENT, FISS DENSITY, ACTIVITY

TS	ELAPSED TIME (S)	BARNS/FISSION (LAST 4 GROUPS)			
1	2.2320E+05	4.2670E-02	1.9407E-01	1.8209E+01	2.3692E+04
2	1.2937E+07	5.1250E-02	2.5627E-01	2.3247E+01	1.0754E+03
3	1.4072E+07	4.7297E-02	2.2595E-01	1.8429E+01	4.7082E+03
4	1.4468E+07	4.7016E-02	2.2243E-01	1.7806E+01	4.2004E+03
5	1.5109E+07	4.8949E-02	2.3672E-01	1.8907E+01	7.8369E+02
6	1.6423E+07	4.8299E-02	2.2756E-01	1.7598E+01	1.9211E+03
7	1.6801E+07	4.9264E-02	2.3460E-01	1.8168E+01	5.0712E+02
8	1.7010E+07	4.8708E-02	2.2966E-01	1.7925E+01	1.8624E+03
9	1.7105E+07	4.9196E-02	2.3263E-01	1.8193E+01	1.7356E+03
10	1.7289E+07	4.8903E-02	2.3042E-01	1.7924E+01	1.6423E+03
11	1.9580E+07	5.1755E-02	2.4459E-01	1.9947E+01	4.5269E+02
12	2.0646E+07	4.9725E-02	2.3427E-01	1.8474E+01	1.1044E+03
13	2.1182E+07	5.0477E-02	2.3996E-01	1.8948E+01	3.3503E+02
14	2.2021E+07	4.9909E-02	2.3492E-01	1.8412E+01	8.7503E+02
15	2.3173E+07	5.0104E-02	2.3584E-01	1.8356E+01	6.8214E+02
16	2.4666E+07	5.1256E-02	2.4360E-01	1.9398E+01	2.4581E+02
17	2.4700E+07	5.1257E-02	2.4367E-01	1.9414E+01	2.5185E+02
18	2.7119E+07	5.0780E-02	2.3966E-01	1.8859E+01	4.7701E+02
19	2.7607E+07	5.0806E-02	2.3972E-01	1.8857E+01	4.5321E+02
20	2.7667E+07	5.0917E-02	2.4043E-01	1.8935E+01	6.2907E+02
21	2.7724E+07	5.0907E-02	2.4046E-01	1.8887E+01	3.7198E+02
22	2.9338E+07	5.1757E-02	2.4111E-01	1.8957E+01	3.7779E+02
23	2.9338E+07	5.1057E-02	2.4111E-01	1.8957E+01	3.7780E+02
24	2.9338E+07	5.1057E-02	2.4111E-01	1.8957E+01	3.7786E+02
25	2.9338E+07	5.1757E-02	2.4111E-01	1.8957E+01	3.7797E+02
26	2.9338E+07	5.1057E-02	2.4112E-01	1.8958E+01	3.7851E+02
27	2.9338E+07	5.1059E-02	2.4112E-01	1.8958E+01	3.7961E+02
28	2.9338E+07	5.1059E-02	2.4112E-01	1.8959E+01	3.8501E+02
29	2.9339E+07	5.1062E-02	2.4114E-01	1.8962E+01	3.9543E+02
30	2.9341E+07	5.1070E-02	2.4119E-01	1.8971E+01	4.3592E+02
31	2.9345E+07	5.1072E-02	2.4123E-01	1.8982E+01	4.8165E+02
32	2.9356E+07	5.1100E-02	2.4135E-01	1.9005E+01	5.6374E+02
33	2.9374E+07	5.1124E-02	2.4152E-01	1.9019E+01	5.8378E+02
34	2.9410E+07	5.1150E-02	2.4180E-01	1.9017E+01	4.6389E+02
35	2.9518E+07	5.1237E-02	2.4243E-01	1.9015E+01	1.9742E+02
36	2.9698E+07	5.1341E-02	2.4322E-01	1.9085E+01	1.5254E+02
37	3.0058E+07	5.1512E-02	2.4438E-01	1.9256E+01	1.5791E+02
38	3.1138E+07	5.1832E-02	2.4646E-01	1.9655E+01	1.6091E+02
39	3.2938E+07	5.2057E-02	2.4821E-01	2.0044E+01	1.6138E+02
40	3.6539E+07	5.2230E-02	2.5002E-01	2.0428E+01	1.6151E+02
41	4.7338E+07	5.2480E-02	2.5182E-01	2.0688E+01	1.6168E+02
42	6.0874E+07	5.2714E-02	2.5216E-01	2.0564E+01	1.6203E+02
43	6.5338E+07	5.2777E-02	2.5216E-01	2.0505E+01	1.6214E+02
44	1.0134E+08	5.3076E-02	2.5175E-01	2.0047E+01	1.6292E+02
45	2.0934E+08	5.3174E-02	2.5045E-01	1.9246E+01	1.6479E+02

TABLE C-XXVI

TMI, UNIT 2, 22-STEP POWER HISTORY, FULL CORE CALC., CINDER-10(LASL) 7/79

SUMMARY OF PROBLEMS OUTPUT

POWER, TOTAL CONTENT, FISSION DENSITY, ACTIVITY

TS	ELAPSED TIME (S)	COOLING TIME (S)	TOTAL NUC	FISSION DENS	ACTIVITY	POWER
1	2.23200E+05	0.	9.37137E+00	4.18487E+00	9.37567E+19	6.11500E+08
2	1.29366E+07	1.27134E+07	9.37175E+00	4.18487E+00	4.61989E+16	0.
3	1.40724E+07	0.	4.49117E+01	2.24508E+01	8.59513E+19	5.24520E+08
4	1.44684E+07	0.	7.18462E+01	3.59149E+01	1.78202E+20	1.10900E+09
5	1.51092E+07	6.40807E+05	7.18471E+01	3.59149E+01	5.70238E+18	0.
6	1.64232E+07	0.	1.91823E+02	9.58909E+01	2.46449E+20	1.48894E+09
7	1.68012E+07	3.78000E+05	1.21874E+02	9.58909E+01	1.59692E+19	0.
8	1.70100E+07	0.	2.22507E+02	1.11231E+02	3.76507E+20	2.39780E+09
9	1.71054E+07	9.54000E+04	2.22509E+02	1.11231E+02	3.23746E+19	0.
10	1.72890E+07	0.	2.45405E+02	1.22679E+02	3.25770E+20	2.03410E+09
11	1.95304E+07	2.29140E+04	2.45407E+02	1.22679E+02	5.75479E+18	0.
12	2.06460E+07	0.	3.82770E+02	1.91357E+02	3.45392E+20	2.10409E+09
13	2.11324E+07	5.36400E+05	3.82772E+02	1.91357E+02	1.80575E+19	0.
14	2.20212E+07	0.	5.09515E+02	2.54733E+02	4.05876E+20	2.46730E+09
15	2.31732E+07	0.	6.70906E+02	3.35397E+02	3.85618E+20	2.28180E+09
16	2.46660E+07	1.49291E+06	6.70907E+02	3.35397E+02	1.61236E+19	0.
17	2.46995E+07	0.	6.70975E+02	3.35431E+02	2.04580E+19	3.34000E+07
18	2.71189E+07	0.	1.02539E+03	5.17777E+02	4.17448E+20	2.46214E+09
19	2.76075E+07	0.	1.11750E+03	5.58856E+02	4.62845E+20	2.74350E+09
20	2.76669E+07	5.94000E+04	1.11750E+03	5.58856E+02	7.85243E+19	0.
21	2.77236E+07	0.	1.12339E+03	5.61806E+02	3.00661E+20	1.69760E+09
22	2.93378E+07	0.	1.39700E+03	6.95228E+02	4.61196E+20	2.69970E+09
23	2.93378E+07	1.00000E+00	1.39700E+03	6.95228E+02	4.39726E+20	0.
24	2.93379E+07	4.00000E+00	1.39700E+03	6.95228E+02	4.09939E+20	0.
25	2.93379E+07	1.00000E+01	1.39700E+03	6.95228E+02	3.80462E+20	0.
26	2.93379E+07	4.00000E+01	1.39700E+03	6.95228E+02	3.25417E+20	0.
27	2.93379E+07	1.00000E+02	1.39700E+03	6.95228E+02	2.87992E+20	0.
28	2.93382E+07	4.00000E+02	1.39700E+03	6.95228E+02	2.36830E+20	0.
29	2.93388E+07	1.00000E+03	1.39700E+03	6.95228E+02	2.04110E+20	0.
30	2.93414E+07	3.60000E+03	1.39700E+03	6.95228E+02	1.57103E+20	0.
31	2.93450E+07	7.20000E+03	1.39700E+03	6.95228E+02	1.36500E+20	0.
32	2.93558E+07	1.80000E+04	1.39700E+03	6.95228E+02	1.13087E+20	0.
33	2.93738E+07	3.60000E+04	1.39700E+03	6.95228E+02	9.59714E+19	0.
34	2.94098E+07	7.20000E+04	1.39700E+03	6.95228E+02	7.90343E+19	0.
35	2.95178E+07	1.80000E+05	1.39700E+03	6.95228E+02	5.90702E+19	0.
36	2.96978E+07	3.60000E+05	1.39700E+03	6.95228E+02	4.66281E+19	0.
37	3.00578E+07	7.20000E+05	1.39700E+03	6.95228E+02	3.54130E+19	0.
38	3.11378E+07	1.80000E+06	1.39700E+03	6.95228E+02	2.24734E+19	0.
39	3.29378E+07	3.60000E+06	1.39700E+03	6.95228E+02	1.46128E+19	0.
40	3.65379E+07	7.20000E+06	1.39799E+03	6.95228E+02	8.49797E+18	0.
41	4.73379E+07	1.80000E+07	1.39999E+03	6.95228E+02	2.93655E+18	0.
42	6.08739E+07	3.15360E+07	1.39999E+03	6.95228E+02	1.31440E+18	0.
43	6.53379E+07	3.60000E+07	1.39999E+03	6.95228E+02	1.10263E+18	0.
44	1.01338E+08	7.20000E+07	1.39999E+03	6.95228E+02	4.67316E+17	0.
45	2.09338E+08	1.90000E+08	1.39994E+03	6.95228E+02	1.51650E+17	0.

TABLE CXXVII

THI, UNIT 2, 22-STEP POWER HISTORY, FULL CORE CALC., CINDER-10(LASL) 7/79

SUMMARY OF PROBLEM OUTPUT

ENERGY DATA (MEV/F) ALL NUCLIDES

TS	COOLING TIME (S)	TOTAL DENS	ACTIVITY	BETA MEV/F	GAMMA MEV/F	TOTAL MEV/F
1	0.	9.37137E+00	9.37567E+19	5.21458E+00	5.80503E+00	1.20196E+01
2	1.27134E+07	8.37176E+00	4.61989E+15	7.85868E-04	8.18572E-04	1.60444E-03
3	0.	4.49112E+01	8.59513E+19	5.30776E+00	5.97155E+00	1.22793E+01
4	0.	7.18462E+01	1.78202E+20	5.27471E+00	5.91864E+00	1.21933E+01
5	6.40800E+05	7.18471E+01	5.70239E+19	4.66826E-02	8.51404E-02	1.31823E-01
6	0.	1.91823E+02	2.46449E+20	5.31017E+00	5.93993E+00	1.23001E+01
7	3.78000E+05	1.91824E+02	1.50692E+19	9.70929E-02	1.74116E-01	2.71209E-01
8	0.	2.22507E+02	3.76507E+20	5.22379E+00	5.84975E+00	1.20735E+01
9	9.54000E+04	2.22509E+02	3.23746E+19	1.46697E-01	2.12227E-01	3.59925E-01
10	0.	2.45406E+02	3.25770E+20	5.24960E+00	5.89508E+00	1.21447E+01
11	2.29140E+06	2.45407E+02	5.75479E+18	2.78111E-02	3.90360E-02	6.68471E-02
12	0.	3.82770E+02	3.45392E+20	5.27945E+00	5.94626E+00	1.22257E+01
13	5.36400E+05	3.82772E+02	1.80575E+19	7.82079E-02	1.34679E-01	2.12887E-01
14	0.	5.09515E+02	4.05976E+20	5.27053E+00	5.94075E+00	1.22113E+01
15	0.	6.70806E+02	3.85518E+20	5.29620E+00	5.99549E+00	1.22917E+01
16	1.49281E+06	6.70807E+02	1.61236E+19	6.87215E-02	1.01924E-01	1.70646E-01
17	0.	6.70875E+02	2.04580E+19	1.05191E+01	1.23084E+01	2.28275E+01
18	0.	1.03532E+03	4.17448E+20	6.28042E+00	5.98059E+00	1.22510E+01
19	0.	1.11750E+03	4.62845E+20	5.25354E+00	5.94884E+00	1.22024E+01
20	5.94000E+04	1.11750E+03	7.85243E+19	3.12430E-01	4.43888E-01	7.56368E-01
21	0.	1.12339E+03	3.00561E+20	6.27578E+00	6.06708E+00	1.23629E+01
22	0.	1.39000E+03	4.61186E+20	6.25950E+00	5.96669E+00	1.22262E+01
23	1.00000E+00	1.39000E+03	4.39726E+20	5.68773E+00	5.53358E+00	1.12213E+01
24	4.00000E+00	1.39000E+03	4.09939E+20	4.98347E+00	5.01853E+00	1.00020E+01
25	1.00000E+01	1.39000E+03	3.80462E+20	4.34924E+00	4.56194E+00	8.91119E+00
26	4.00000E+01	1.39000E+03	3.25417E+20	3.30255E+00	3.71468E+00	7.01722E+00
27	1.00000E+02	1.39000E+03	2.87392E+20	2.65002E+00	3.10892E+00	5.76894E+00
28	4.00000E+02	1.39000E+03	2.36330E+20	1.88353E+00	2.34725E+00	4.23079E+00
29	1.00000E+03	1.39000E+03	2.04110E+20	1.47043E+00	1.93313E+00	3.40356E+00
30	3.60000E+03	1.39000E+03	1.57103E+20	2.66806E-01	1.30642E+00	2.27323E+00
31	7.20000E+03	1.39000E+03	1.35507E+20	7.59429E-01	9.99050E-01	1.76848E+00
32	1.80000E+04	1.39000E+03	1.13087E+20	5.61617E-01	7.01234E-01	1.26285E+00
33	3.60000E+04	1.39000E+03	9.59714E+19	4.22372E-01	5.59211E-01	9.81583E-01
34	7.20000E+04	1.39000E+03	7.90343E+19	2.05970E-01	4.50542E-01	7.56512E-01
35	1.30000E+05	1.39000E+03	5.90702E+19	2.05986E-01	3.34879E-01	5.40866E-01
36	3.60000E+05	1.39000E+03	4.64281E+19	1.59870E-01	2.63655E-01	4.23525E-01
37	7.20000E+05	1.39000E+03	3.54130E+19	1.24088E-01	1.95620E-01	3.19709E-01
38	1.80000E+06	1.39000E+03	2.74734E+19	9.10989E-02	1.11906E-01	1.93005E-01
39	3.60000E+06	1.39000E+03	1.46128E+19	5.29149E-02	6.36475E-02	1.16562E-01
40	7.20000E+06	1.39000E+03	8.42797E+18	3.20401E-02	3.39143E-02	6.59543E-02
41	1.80000E+07	1.33999E+03	2.93555E+18	1.41514E-02	9.96273E-03	2.41142E-02
42	3.60000E+07	1.39999E+03	1.31440E+18	7.95528E-03	2.48154E-03	1.04478E-02
43	3.60000E+07	1.38999E+03	1.12263E+18	4.22002E-03	1.68930E-03	8.60932E-03
44	7.20000E+07	1.38997E+03	4.67316E+17	2.72614E-03	4.29909E-04	3.22604E-03
45	1.80000E+08	1.38994E+03	1.51550E+17	5.68956E-04	2.35494E-04	8.04460E-04

TABLE C-XXVII

TMI, UNIT 2, 22-STEP POWER HISTORY, FULL CORE CALC., CINDER-10(LASL) 7/79

SUMMARY OF PROGRAM OUTPUT

TOTAL GAS FRACTIONS

GAS FRACTIONS OF TOTAL NUCLIDE VALUES

TS	COOLING TIME (S)	DENSITY	ρ-DENSITY	ACTIVITY	BETA	GAMMA	TOTAL
1	0.	1.6319E-01	5.934E-02	1.792E-01	2.0144E-01	2.4566E-01	2.2280E-01
2	1.2713E+07	1.4063E-01	4.479E-03	4.707E-04	3.7932E-04	1.4857E-05	1.9337E-04
3	0.	1.5244E-01	2.953E-02	2.025E-01	2.0193E-01	2.4968E-01	2.2515E-01
4	0.	1.5513E-01	3.009E-02	1.992E-01	2.0116E-01	2.4803E-01	2.2391E-01
5	6.4080E+05	1.4915E-01	1.479E-02	2.204E-01	1.6107E-01	2.4923E-01	2.1801E-01
6	0.	1.5578E-01	2.194E-02	1.985E-01	2.0024E-01	2.4785E-01	2.2343E-01
7	3.7800E+05	1.5297E-01	1.440E-02	2.195E-01	1.7318E-01	2.7912E-01	2.4119E-01
8	0.	1.5446E-01	1.849E-02	1.933E-01	1.9891E-01	2.4344E-01	2.2049E-01
9	9.5400E+04	1.5346E-01	1.614E-02	2.409E-01	2.1494E-01	3.5139E-01	2.9562E-01
10	0.	1.5427E-01	1.790E-02	1.947E-01	1.9895E-01	2.4447E-01	2.2105E-01
11	2.2914E+06	1.4985E-01	5.177E-03	3.913E-02	1.9629E-02	2.6944E-02	2.3901E-02
12	0.	1.5482E-01	1.552E-02	1.957E-01	1.9883E-01	2.4677E-01	2.2215E-01
13	5.3640E+05	1.5265E-01	9.725E-03	1.900E-01	1.4221E-01	2.3689E-01	2.0211E-01
14	0.	1.5519E-01	1.438E-02	1.941E-01	1.9770E-01	2.4532E-01	2.2087E-01
15	0.	1.5561E-01	1.312E-02	1.933E-01	1.9656E-01	2.4425E-01	2.1982E-01
16	1.4928E+06	1.5250E-01	5.788E-03	6.949E-02	3.8068E-02	5.5343E-02	4.8386E-02
17	0.	1.5248E-01	5.749E-03	9.417E-02	1.2681E-01	1.3305E-01	1.3018E-01
19	0.	1.5550E-01	1.054E-02	1.904E-01	1.9457E-01	2.4248E-01	2.1794E-01
19	0.	1.5567E-01	1.043E-02	1.895E-01	1.9349E-01	2.4150E-01	2.1690E-01
20	5.9400E+04	1.5546E-01	1.007E-02	2.189E-01	1.8919E-01	3.3347E-01	2.7387E-01
21	0.	1.5542E-01	9.992E-03	1.893E-01	1.9331E-01	2.4072E-01	2.1658E-01
22	0.	1.5570E-01	9.703E-03	1.974E-01	1.9213E-01	2.4012E-01	2.1555E-01
23	1.0000E+00	1.5570E-01	9.708E-03	1.893E-01	1.9589E-01	2.4542E-01	2.2031E-01
24	4.0000E+00	1.5570E-01	9.703E-03	1.903E-01	1.9607E-01	2.4852E-01	2.2239E-01
25	1.0000E+01	1.5570E-01	9.708E-03	1.913E-01	1.9507E-01	2.5060E-01	2.2350E-01
26	4.0000E+01	1.5570E-01	9.707E-03	1.901E-01	1.8444E-01	2.5205E-01	2.2023E-01
27	1.0000E+02	1.5570E-01	9.704E-03	1.873E-01	1.6950E-01	2.5351E-01	2.1478E-01
28	4.0000E+02	1.5570E-01	9.702E-03	1.871E-01	1.4802E-01	2.7131E-01	2.1642E-01
29	1.0000E+03	1.5570E-01	9.696E-03	1.944E-01	1.4608E-01	2.9767E-01	2.3218E-01
30	3.6000E+03	1.5570E-01	9.671E-03	2.168E-01	1.6834E-01	3.5919E-01	2.7802E-01
31	7.2000E+03	1.5569E-01	9.634E-03	2.204E-01	1.6991E-01	3.7727E-01	2.8705E-01
32	1.8000E+04	1.5555E-01	9.543E-03	2.144E-01	1.6187E-01	3.5308E-01	2.6805E-01
33	3.6000E+04	1.5560E-01	9.407E-03	2.127E-01	1.7243E-01	3.3399E-01	2.6447E-01
34	7.2000E+04	1.5550E-01	9.161E-03	2.065E-01	1.8156E-01	3.1010E-01	2.5811E-01
35	1.8000E+05	1.5527E-01	8.542E-03	1.834E-01	1.5684E-01	2.6457E-01	2.2354E-01
36	3.6000E+05	1.5497E-01	7.748E-03	1.589E-01	1.2105E-01	2.0862E-01	1.7557E-01
37	7.2000E+05	1.5449E-01	6.619E-03	1.171E-01	7.6688E-02	1.2789E-01	1.0801E-01
38	1.8000E+06	1.5336E-01	5.234E-03	4.036E-02	2.1536E-02	3.1678E-02	2.7416E-02
39	3.6000E+06	1.5374E-01	4.943E-03	7.071E-03	3.7896E-03	5.7297E-03	4.8489E-03
40	7.2000E+06	1.5384E-01	4.877E-03	6.345E-04	4.6775E-04	8.214E-04	3.7231E-04
41	1.8000E+07	1.5390E-01	4.904E-03	1.174E-03	7.3872E-04	9.4068E-04	4.3740E-04
42	3.1536E+07	1.5388E-01	4.877E-03	2.552E-03	1.2764E-03	3.6465E-03	9.8189E-04
43	3.6000E+07	1.5388E-01	4.867E-03	3.014E-03	1.4560E-03	5.3079E-03	1.1807E-03
44	7.2000E+07	1.5380E-01	4.784E-03	6.606E-03	3.3474E-03	1.9375E-04	2.9272E-03
45	1.8000E+08	1.5359E-01	4.569E-03	1.632E-02	1.3188E-02	2.8356E-04	9.4102E-03

TABLE C-XXIX

TMI, UNIT 2, 22-STEP POWER HISTORY, FULL CORE CALC., CINDER-10(LASL) 7/79

SUMMARY OF PROBLEM OUTPUT

NORLE GAS FRACTIONS

NORLE GAS FRACTIONS OF TOTAL NUCLIDE VALUES

TS	COOLING TIME (S)	DENSITY	ρ-DENSITY	ACTIVITY	BETA	GAMMA	TOTAL
1	0.	1.2747E-01	2.471E-02	1.040E-01	1.0069E-01	9.8800E-02	9.9776E-02
2	1.2713E+07	1.3540E-01	1.297E-03	4.933E-04	3.7504E-04	6.2312E-06	1.8688E-04
3	0.	1.3767E-01	1.517E-02	1.059E-01	9.9893E-02	9.6671E-02	9.8326E-02
4	0.	1.3899E-01	1.534E-02	1.070E-01	9.9457E-02	9.6649E-02	9.8094E-02
5	5.4090E+05	1.4071E-01	7.884E-03	1.265E-01	4.5449E-02	2.0964E-02	2.9635E-02
6	0.	1.4248E-01	1.122E-02	1.073E-01	9.8584E-02	9.5151E-02	9.6912E-02
7	3.7900E+05	1.4466E-01	7.922E-03	1.202E-01	4.3143E-02	2.0647E-02	2.8701E-02
8	0.	1.4282E-01	9.341E-03	1.001E-01	9.8752E-02	9.6243E-02	9.7536E-02
9	9.5400E+04	1.4406E-01	9.270E-03	1.055E-01	5.1137E-02	3.2464E-02	4.0096E-02
10	0.	1.4333E-01	9.455E-03	1.075E-01	9.8509E-02	9.5640E-02	9.7117E-02
11	2.2914E+06	1.4365E-01	1.599E-03	1.921E-02	6.0665E-03	3.5729E-03	4.6103E-03
12	0.	1.4527E-01	7.491E-03	1.001E-01	9.7804E-02	9.4549E-02	9.6220E-02
13	5.3640E+05	1.4595E-01	4.609E-03	1.075E-01	3.8413E-02	1.8897E-02	2.6067E-02
14	0.	1.4601E-01	6.739E-03	9.899E-02	9.7221E-02	9.3870E-02	9.5591E-02
15	0.	1.4704E-01	6.120E-03	9.897E-02	9.6513E-02	9.2623E-02	9.4616E-02
16	1.4928E+06	1.4695E-01	1.894E-03	3.756E-02	1.2710E-02	6.9985E-03	9.2986E-03
17	0.	1.4634E-01	1.857E-03	5.117E-02	6.1943E-02	4.7227E-02	5.4009E-02
18	0.	1.4788E-01	4.639E-03	9.717E-02	9.5480E-02	9.1478E-02	9.3528E-02
19	0.	1.4801E-01	4.599E-03	9.629E-02	9.4940E-02	9.0963E-02	9.3001E-02
20	5.9400E+04	1.4827E-01	4.507E-03	9.694E-02	4.3547E-02	3.1063E-02	3.6221E-02
21	0.	1.4820E-01	4.400E-03	9.764E-02	9.4703E-02	8.9189E-02	9.1997E-02
22	0.	1.4839E-01	4.044E-03	9.519E-02	9.4197E-02	8.9975E-02	9.2136E-02
23	1.0000E+00	1.4939E-01	4.044E-03	9.573E-02	9.6317E-02	9.0957E-02	9.3674E-02
24	4.0000E+00	1.4839E-01	4.044E-03	9.589E-02	9.7178E-02	9.1139E-02	9.4148E-02
25	1.0000E+01	1.4839E-01	4.044E-03	9.607E-02	9.7994E-02	9.1387E-02	9.4606E-02
26	4.0000E+01	1.4839E-01	4.044E-03	9.363E-02	9.4880E-02	8.8340E-02	9.1418E-02
27	1.0000E+02	1.4839E-01	4.043E-03	9.034E-02	8.8327E-02	8.4496E-02	8.6263E-02
28	4.0000E+02	1.4839E-01	4.041E-03	9.344E-02	6.7824E-02	7.7715E-02	7.3312E-02
29	1.0000E+03	1.4939E-01	4.039E-03	7.845E-02	4.9929E-02	7.0483E-02	6.1603E-02
30	3.6000E+03	1.4841E-01	4.036E-03	9.070E-02	4.2519E-02	6.7520E-02	5.6945E-02
31	7.2000E+03	1.4844E-01	4.034E-03	9.431E-02	3.9804E-02	6.7775E-02	5.5605E-02
32	1.8000E+04	1.4849E-01	4.028E-03	9.771E-02	3.6151E-02	5.5564E-02	4.6931E-02
33	3.6000E+04	1.4855E-01	4.007E-03	9.092E-02	3.8817E-02	3.8291E-02	3.8512E-02
34	7.2000E+04	1.4861E-01	3.932E-03	9.347E-02	4.1940E-02	2.7089E-02	3.3095E-02
35	1.8000E+05	1.4869E-01	3.630E-03	9.029E-02	3.4124E-02	1.8389E-02	2.4381E-02
36	3.6000E+05	1.4867E-01	3.123E-03	9.541E-02	3.0051E-02	1.5624E-02	2.1070E-02
37	7.2000E+05	1.4954E-01	2.356E-03	6.563E-02	2.2759E-02	1.2000E-02	1.6176E-02
38	1.8000E+06	1.4839E-01	1.473E-03	2.043E-02	6.9323E-03	4.0946E-03	5.2870E-03
39	3.6000E+06	1.4944E-01	1.265E-03	2.447E-03	8.8388E-04	5.4904E-04	7.0104E-04
40	7.2000E+06	1.4847E-01	1.239E-03	4.671E-04	3.3835E-04	2.5531E-05	1.7750E-04
41	1.8000E+07	1.4844E-01	1.212E-03	1.174E-03	7.3871E-04	9.3882E-06	4.3739E-04
42	3.1536E+07	1.4841E-01	1.179E-03	2.552E-03	1.2764E-03	3.6464E-05	9.8189E-04
43	3.6000E+07	1.4840E-01	1.168E-03	3.014E-03	1.4560E-03	5.3077E-05	1.1807E-03
44	7.2000E+07	1.4932E-01	1.085E-03	6.604E-03	3.3474E-03	1.9375E-04	2.9272E-03
45	1.8000E+08	1.4811E-01	8.499E-04	1.632E-02	1.3188E-02	2.8354E-04	9.4102E-03

TABLE C-XXX

TMI-2 IF OPERATED 26K HRS AT 2772. MW CONT. CINDER-10(LASL)8/79

CONTENT OF NOBLE GASES AND HALOGENS
(EXCEEDING 1.00000E-02 PERCENT OF TOTAL GAS)

TIME STEP 22
 ELAPSED TIME=9.34916E+07 SEC
 COOLING TIME=0. SEC
 TOTAL ACTIVITY=3.08026E+09
 CURIES IN ALL FP= 1.07818E+10
 IN ALL GAS= 1.65495E+09
 IN HALOGENS= 8.71078E+08
 IN NOBLE GAS= 7.93876E+08
 TOTAL BETA MEV/FISS=5.91497E+00
 TOTAL GAMMA MEV/FISS=5.54930E+00
 TOTAL BETA+GAMMA=1.14643E+01
 FRACTION OF TOTALS IN GAS PRODUCTS
 BETA FRACTION=1.53027E-01
 GAMMA FRACTION=2.10133E-01
 TOTAL FRACTION=1.80669E-01
 FRACTIONAL DENSITY ALL GAS=1.55526E-01
 DENSITY OF RADIOACTIVE GAS=6.21837E-03
 FRACTIONAL GAS ACTIVITY=1.53495E-01

DECAY POWER IN MW FOR ALL FP IS
 TOTAL BETA MW=6.52732E+01
 TOTAL GAMMA MW=6.12379E+01
 TOTAL BETA+GAMMA MW=1.26511E+02
 (MULTIPLY MEV/F BY 1.10352E+01 TO GET MW)

TABULAR VALUES ARE GIVEN AS FRACTIONS OF ALL NUCLIDES

NUCLIDE		DENSITY	CURIES	BETA MEV/F	GAMMA MEV/F	B+G MEV/F
Z	A S					
35BR	83 0	2.21179E-07	6.40709E-04	2.03257E-04	4.88132E-06	1.07233E-04
35BR	84 0	8.33663E-08	1.09256E-03	1.34457E-03	2.00039E-03	1.66202E-03
35BR	85 0	9.01849E-09	1.31079E-03	1.27689E-03	8.84820E-05	7.01641E-04
36KR	85 1	8.59493E-07	1.33381E-03	2.95255E-04	2.55048E-04	2.75792E-04
35BR	86 0	1.99145E-09	9.06229E-04	1.57516E-03	3.13797E-03	2.33164E-03
35BR	86 1	1.63852E-10	9.11316E-04	2.75318E-03	1.58462E-03	2.18753E-03
35BR	87 0	4.77709E-09	2.14269E-03	4.49040E-03	3.86035E-03	4.18026E-03
36KR	87 0	4.50399E-07	2.47208E-03	3.23014E-03	2.04490E-03	2.65642E-03
35BR	88 0	1.40258E-09	2.21892E-03	6.46353E-03	4.35601E-03	5.54657E-03
36KR	88 0	1.42764E-08	3.54477E-03	8.62769E-04	8.18262E-03	4.40596E-03
35BR	89 0	2.65277E-10	1.47932E-03	4.07737E-03	3.06014E-03	3.58498E-03
36KR	89 0	3.24897E-08	4.28882E-03	5.21222E-03	9.23416E-03	7.15905E-03
35BR	90 0	5.83240E-11	9.12347E-04	2.92996E-03	2.20492E-03	2.61512E-03
36KR	90 0	5.44883E-09	4.22213E-03	4.90719E-03	7.70735E-03	6.26262E-03
35BR	91 0	7.32512E-12	3.05599E-04	9.17071E-04	7.42007E-04	8.32306E-04
36KR	91 0	1.07880E-09	3.10351E-03	7.83324E-03	2.34359E-03	5.17597E-03
35BR	92 0	5.05561E-13	4.21774E-05	1.52982E-04	1.31418E-04	1.42544E-04
36KR	92 0	1.16454E-10	1.58405E-03	3.72734E-03	1.24293E-03	2.52476E-03
36KR	93 0	3.08608E-11	6.08192E-04	1.64224E-03	1.29459E-03	1.47396E-03
36KR	94 0	1.79923E-12	2.14434E-04	4.34681E-04	4.02385E-04	4.19048E-04
53 I130	0	3.75752E-07	2.10665E-04	6.08492E-05	4.66104E-04	2.57014E-04

53 I131 0	1.64553E-04	5.92810E-03	1.07471E-03	2.40842E-03	1.72133E-03
53 I132 0	2.81355E-05	9.56043E-03	4.39774E-03	1.99918E-02	1.19461E-02
53 I133 0	3.52704E-05	1.17889E-02	4.91546E-03	7.36857E-03	6.05130E-03
54XE133 0	2.17750E-04	1.19235E-02	1.19941E-03	1.01344E-03	1.10423E-03
53 I134 0	1.59170E-04	1.26228E-02	8.53943E-03	3.41542E-02	2.09383E-02
53 I134 1	1.21999E-08	1.41343E-03	0.	4.65761E-04	2.25452E-04
54XE134 1	1.31370E-12	1.13395E-04	0.	2.36689E-04	1.14570E-04
53 I135 0	1.03546E-05	1.09320E-02	4.21356E-03	1.66117E-02	1.02149E-02
54XE135 0	2.81263E-05	2.13242E-03	5.47025E-04	5.81813E-04	6.15459E-04
54XE135 1	8.84982E-08	2.41280E-03	0.	1.32659E-03	6.42141E-04
53 I136 0	1.63631E-09	4.93422E-03	9.74952E-03	1.13986E-02	1.00318E-02
53 I136 1	5.52184E-09	2.87321E-03	5.46629E-03	5.78572E-03	5.62091E-03
53 I137 0	4.73707E-09	4.81953E-03	7.14730E-03	1.02036E-02	8.62673E-03
54XE137 0	9.35926E-08	1.01669E-02	1.83239E-02	2.07184E-03	1.04570E-02
53 I138 0	6.32246E-10	2.43444E-03	5.05715E-03	6.86273E-03	5.93114E-03
54XE138 0	3.16728E-07	9.30417E-03	5.99164E-03	1.16044E-02	8.70849E-03
53 I139 0	1.12598E-10	1.17422E-03	2.01339E-03	3.03024E-03	2.50559E-03
54XE139 0	1.13585E-09	7.03671E-03	1.23106E-02	6.81135E-03	9.64866E-03
53 I140 0	1.24565E-11	3.62517E-04	7.40888E-04	1.10944E-03	9.19289E-04
54XE140 0	2.45286E-09	4.51404E-03	3.89271E-03	6.41836E-03	5.11525E-03
53 I141 0	1.10131E-12	4.89470E-05	1.31499E-04	2.07644E-04	1.68357E-04
54XE141 0	1.09904E-10	1.59924E-03	2.46060E-03	3.78891E-03	3.10357E-03
54XE142 0	3.13877E-11	4.42917E-04	6.91823E-04	1.18639E-03	9.31218E-04
54XE143 0	1.44972E-12	1.20946E-04	2.13029E-04	3.39407E-04	2.74203E-04

TOTAL GAS 2.24027E+03 1.65495E+09 9.05151E-01 1.16609E+00 2.07124E+00
8.95723E+01 (RADIOACTIVE GAS DENSITY)

TOTAL FP 1.44045E+04 1.07919E+10 5.91497E+00 5.54930E+00 1.14643E+01

TOTAL GAS FRACTIONS 1.55526E-01 1.53495E-01 1.53027E-01 2.10133E-01 1.80669E-01
6.21837E-03 (RADIOACTIVE FRACTION OF TOTAL FP)

NOBLE GAS FRACTIONS 1.48297E-01 7.27037E-02 7.40230E-02 6.84145E-02 7.13082E-02
1.16532E-03 (NOBLE RADIOACTIVE GAS FRACTION OF TOTAL FP)

TABLE C-XXXI

TMI-2 IF OPERATED 26K HRS AT 2772. MW CONT. CINDER-10(LASL)8/79

CONTENT OF NOBLE GASES AND HALOGENS
(EXCEEDING 1.00000E-02 PERCENT OF TOTAL GAS)

TIME STEP 23
ELAPSED TIME=9.34916E+07 SEC
COOLING TIME=1.00000E+00 SEC
TOTAL ACTIVITY=3.83449E+20
CURIES IN ALL FP= 1.03634E+10
IN ALL GAS= 1.60556E+09
IN HALOGENS= 8.50323E+03
TOTAL BETA MEV/FISS=5.43328E+00
TOTAL GAMMA MEV/FISS=5.18148E+00

TOTAL BETA+GAMMA=1.06149E+01
 FRACTION OF TOTALS IN GAS PRODUCTS
 BETA FRACTION=1.56400E-01
 GAMMA FRACTION=2.15243E-01
 TOTAL FRACTION=1.85123E-01
 FRACTIONAL DENSITY ALL GAS=1.55526E-01
 DENSITY OF RADIOACTIVE GAS=5.21934E-03
 FRACTIONAL GAS ACTIVITY=1.54926E-01

DECAY POWER IN MW FOR ALL FD IS
 TOTAL BETA MW=5.92574E+01
 TOTAL GAMMA MW=5.71799E+01
 TOTAL BETA+GAMMA MW=1.17136E+02
 (MULTIPLY MEV/F BY 1.10352E+01 TO GET MW)

TABULAR VALUES ARE GIVEN AS FRACTIONS OF ALL NUCLIDES

NUCLIDE	DENSITY	CURIES	BETA MEV/F	GAMMA MEV/F	B+G MEV/F
Z A S					
35BR 83 0	2.21178E-07	6.66570E-04	2.21276E-04	5.22782E-06	1.15814E-04
35BR 84 0	8.33649E-08	1.13769E-03	1.44374E-03	2.14235E-03	1.79500E-03
35BR 84 1	7.69720E-10	5.56733E-05	5.10829E-05	1.65587E-04	1.06977E-04
35BR 85 0	9.00986E-09	1.34739E-03	1.39877E-03	9.46725E-05	7.57069E-04
36KR 85 1	8.59498E-07	1.3976E-03	3.21430E-04	2.73153E-04	2.97864E-04
35BR 86 0	1.98106E-09	9.37892E-04	1.70586E-03	3.34319E-03	2.50511E-03
35BR 86 1	1.54025E-10	8.91245E-04	2.91751E-03	1.59533E-03	2.22092E-03
35BR 87 0	4.74345E-09	2.21349E-03	4.84326E-03	4.10528E-03	4.48302E-03
36KR 87 0	4.50390E-07	2.57187E-03	3.51644E-03	2.19001E-03	2.96876E-03
35BR 88 0	1.35704E-09	2.22234E-03	6.98392E-03	4.49136E-03	5.76720E-03
36KR 88 0	1.42760E-06	3.68777E-03	9.39233E-04	8.76326E-03	4.75844E-03
35BR 89 0	2.29256E-10	1.32656E-03	3.92602E-03	2.82490E-03	3.33734E-03
36KR 89 0	3.24092E-08	4.45089E-03	5.64225E-03	9.86516E-03	7.71293E-03
35BR 90 0	3.81832E-11	6.21398E-04	2.13812E-03	1.54598E-03	1.64907E-03
36KR 90 0	5.35352E-09	4.31573E-03	5.24980E-03	8.11010E-03	6.84551E-03
35BR 91 0	2.31895E-12	1.00637E-04	3.16044E-04	2.51577E-04	2.84575E-04
36KR 91 0	1.00110E-09	2.29623E-03	7.91349E-03	2.32917E-03	5.18757E-03
36KR 92 0	8.01644E-11	1.13444E-03	2.79329E-03	9.16344E-04	1.87709E-03
36KR 93 0	1.79264E-11	3.57541E-04	1.02951E-03	8.05383E-04	9.24713E-04
53 I130 0	3.75750E-07	2.19168E-04	6.62434E-05	4.99189E-04	2.77581E-04
53 I131 0	1.64553E-04	6.16740E-03	1.17217E-03	2.57939E-03	1.85909E-03
53 I132 0	2.81354E-06	9.90598E-03	4.78762E-03	2.14109E-02	1.29021E-02
53 I133 0	3.52704E-05	1.22648E-02	5.24237E-03	7.89164E-03	6.53559E-03
54XE133 0	2.17750E-04	1.24048E-02	1.27486E-03	1.08538E-03	1.19260E-03
53 I134 0	1.59153E-05	1.31317E-02	9.29606E-03	3.65771E-02	2.26130E-02
53 I134 1	1.21608E-08	1.46598E-03	0.	4.97226E-04	2.42715E-04
53 I135 0	1.03544E-05	1.13731E-02	4.58704E-03	1.77907E-02	1.10322E-02
54XE135 0	2.81289E-05	2.21871E-03	7.04454E-04	6.23173E-04	6.64777E-04
54XE135 1	8.34759E-08	2.50957E-03	0.	1.42041E-03	6.93358E-04
53 I136 0	1.62941E-08	5.11174E-03	9.49501E-03	1.21562E-02	1.07889E-02
53 I136 1	5.44267E-09	2.95249E-03	5.86559E-03	6.10760E-03	5.98372E-03
53 I137 0	4.62664E-09	4.89720E-03	7.52956E-03	1.06732E-02	9.09994E-03
54XE137 0	9.34376E-08	1.05598E-02	1.99153E-02	2.21524E-03	1.12752E-02
53 I138 0	5.74131E-10	2.29902E-03	4.92244E-03	6.67431E-03	5.91701E-03
54XE138 0	3.16536E-07	9.67389E-03	6.51987E-03	1.24206E-02	9.39974E-03
53 I139 0	8.50658E-11	2.22915E-04	1.45592E-03	2.45180E-03	2.04442E-03
54XE139 0	1.11928E-08	7.21396E-03	1.32064E-02	7.18844E-03	1.02688E-02
53 I140 0	5.56676E-12	1.71575E-04	3.64929E-04	5.40541E-04	4.51676E-04
54XE140 0	2.33568E-09	4.47199E-03	4.03536E-03	6.54558E-03	5.26070E-03
54XE141 0	7.40735E-11	1.12138E-03	1.90544E-03	2.73495E-03	2.25917E-03
54XE142 0	1.78541E-11	3.81062E-04	4.28414E-04	7.22754E-04	5.72093E-04

TOTAL GAS 2.24027E+02 1.60556E+09 9.49763E-01 1.11528E+00 1.96504E+00
 8.95722E+01 (RADIOLACTIVE GAS DENSITY)

TOTAL FP 1.44045E+04 1.03534E+10 5.43329E+00 5.18148E+00 1.06148E+01

TOTAL GAS
 FRACTIONS 1.55526E-01 1.54026E-01 1.56400E-01 2.15243E-01 1.85123E-01
 6.21836E-03 (RADIOLACTIVE FRACTION OF TOTAL FP)

NOBLE GAS
 FRACTIONS 1.48297E-01 7.28755E-02 7.54494E-02 6.85263E-02 7.20695E-02
 1.16532E-03 (NOBLE RADIOLACTIVE GAS FRACTION OF TOTAL FP)

TABLE G-XXVII

TMI-2 IF OPERATED 26K HRS AT 2772. MW CONT. CINDER-10(LASL)8/79

CONTENT OF NOBLE GASES AND HALOGENS
 (EXCEEDING 1.00000E-02 PERCENT OF TOTAL GAS)

TIME STEP 24
 ELAPSED TIME=9.34916E+07 SEC
 COOLING TIME=4.00000E+00 SEC
 TOTAL ACTIVITY=3.61232E+20
 CURIES IN ALL FP= 9.76303E+09
 IN ALL GAS= 1.52444E+09
 IN HALOGENS= 8.14380E+09
 IN NOBLE GAS= 7.12055E+09
 TOTAL BETA MEV/FISS=4.92391E+00
 TOTAL GAMMA MEV/FISS=6.73208E+00
 TOTAL BETA+GAMMA=9.55599E+00
 FRACTION OF TOTALS IN GAS PROJECTS
 BETA FRACTION=1.58157E-01
 GAMMA FRACTION=2.19798E-01
 TOTAL FRACTION=1.99682E-01
 FRACTIONAL DENSITY ALL GAS=1.55526E-01
 DENSITY OF RADIOLACTIVE GAS=6.21836E-03
 FRACTIONAL GAS ACTIVITY=1.56349E-01

DECAY POWER IN MW FOR ALL FP IS
 TOTAL BETA MW=5.32319E+01
 TOTAL GAMMA MW=5.22197E+01
 TOTAL BETA+GAMMA MW=1.05452E+02
 (MULTIPLY MEV/F BY 1.10352E+01 TO GET MW)

TABULAR VALUES ARE GIVEN AS FRACTIONS OF ALL NUCLIDES

NUCLIDE	DENSITY	CURIES	BETA MEV/F	GAMMA MEV/F	B+G MEV/F
Z A S					
35BR 83 0	2.21176E-07	7.07557E-04	2.49231E-04	5.72424E-06	1.28646E-04
35BR 84 0	8.33600E-08	1.20758E-03	1.64952E-03	2.34567E-03	1.99378E-03
35BR 84 1	7.65287E-10	5.87569E-05	5.72057E-05	1.80268E-04	1.18146E-04
35BR 85 0	8.98028E-09	1.44143E-03	1.55917E-03	1.03323E-04	8.38197E-04
36KR 85 1	8.59496E-07	1.47299E-03	3.62041E-04	2.99093E-04	3.30869E-04

358R 86 0	1.94732E-09	9.78616E-04	1.89867E-03	3.59835E-03	2.73530E-03
358R 86 1	1.29336E-10	7.04410E-04	2.4441E-03	1.46683E-03	2.07157E-03
358R 87 0	4.62884E-09	2.29295E-03	5.32339E-03	4.38654E-03	4.85947E-03
36KR 87 0	4.50359E-07	2.72280E-03	3.96044E-03	2.39783E-03	3.18654E-03
358R 88 0	1.19995E-09	2.08577E-03	6.95512E-03	4.34823E-03	5.66419E-03
36KR 88 0	1.42747E-06	3.91422E-03	1.05781E-03	9.59463E-03	5.28525E-03
358R 89 0	1.44636E-10	9.88394E-04	2.71978E-03	1.95146E-03	2.33891E-03
36KR 89 0	3.21401E-08	4.68532E-03	6.32247E-03	1.07124E-02	8.49634E-03
358R 90 0	1.04817E-11	1.81071E-04	6.61096E-04	4.64692E-04	5.63837E-04
36KR 90 0	5.04655E-09	4.31847E-03	5.57297E-03	8.37111E-03	6.95861E-03
36KR 91 0	7.90163E-10	2.51035E-03	7.03525E-03	2.01299E-03	4.54822E-03
36KR 92 0	2.59069E-11	3.89165E-04	1.01677E-03	3.24260E-04	6.73837E-04
36KR 93 0	3.48708E-12	7.58919E-05	2.27539E-04	1.71543E-04	1.99809E-04
53 I130 0	3.75743E-07	2.32443E-04	7.46117E-05	5.46586E-04	3.08334E-04
53 I131 0	1.64553E-04	6.54449E-03	1.32027E-03	2.82434E-03	2.06509E-03
53 I132 0	2.81353E-06	9.45344E-03	5.39249E-03	2.34442E-02	1.43317E-02
53 I133 0	3.52703E-05	1.30191E-02	5.90471E-03	8.64107E-03	7.25976E-03
54XE133 0	2.17750E-04	1.31577E-02	1.45844E-03	1.18845E-03	1.32475E-03
53 I134 0	1.59140E-06	1.39374E-02	1.04691E-02	4.00451E-02	2.51152E-02
53 I134 1	1.20443E-08	1.54123E-03	0.	5.39230E-04	2.67027E-04
53 I135 0	1.03538E-05	1.20713E-02	5.16631E-03	1.94791E-02	1.22540E-02
54XE135 0	2.81369E-06	2.35583E-03	7.93684E-04	6.82548E-04	7.38649E-04
54XE135 1	8.84093E-08	2.66190E-03	0.	1.55413E-03	7.69607E-04
53 I136 0	1.60776E-08	5.35401E-03	1.05415E-02	1.31338E-02	1.18252E-02
53 I136 1	5.21192E-09	3.00110E-03	6.32659E-03	6.40409E-03	6.36497E-03
53 I137 0	4.29364E-09	4.87421E-03	7.96365E-03	1.08457E-02	9.38073E-03
54XE137 0	9.29570E-08	1.11514E-02	2.23162E-02	2.41314E-03	1.24602E-02
53 I138 0	4.23928E-10	1.80266E-03	4.15790E-03	5.39621E-03	4.77111E-03
54XE138 0	3.15924E-07	1.02490E-02	7.32831E-03	1.35739E-02	1.04211E-02
53 I139 0	3.58492E-11	4.13993E-04	7.86466E-04	1.13202E-03	9.57593E-04
54XE139 0	1.06750E-08	7.30405E-03	1.41882E-02	7.50769E-03	1.08809E-02
54XE140 0	2.00775E-09	4.08044E-03	3.90707E-03	6.16092E-03	5.02318E-03
54XE141 0	2.21770E-11	3.56379E-04	6.08928E-04	8.96583E-04	7.51324E-04
54XE142 0	3.24794E-12	7.35842E-05	8.77821E-05	1.43967E-04	1.15605E-04
TOTAL GAS	2.24027E+03	1.52644E+09	7.62921E-01	1.04010E+00	1.80302E+00
	8.95722E+01	(RADIOACTIVE GAS DENSITY)			
TOTAL FP	1.44045E+04	2.76303E+09	4.82381E+00	4.73208E+00	9.55589E+00
TOTAL GAS FRACTIONS	1.55526E-01	1.56348E-01	1.59157E-01	2.19798E-01	1.88682E-01
	6.21836E-03	(RADIOACTIVE FRACTION OF TOTAL FP)			
NOBLE GAS FRACTIONS	1.48297E-01	7.29338E-02	7.52481E-02	6.82082E-02	7.22768E-02
	1.16532E-03	(NOBLE RADIOACTIVE GAS FRACTION OF TOTAL FP)			

TABLE C-VXXIII

TMI-2 IF OPERATED 26K HRS AT 2772. MW CONT. CINDER-10(LASL)8/79

CONTENT OF NOBLE GASES AND HALOGENS
(EXCEEDING 1.00000E-02 PERCENT OF TOTAL GAS)

TIME STEP 25
ELAPSED TIME=9.34917E+07 SEC

COOLING TIME=1.00000E+01 SEC
TOTAL ACTIVITY=3.39753E+20
CURIES IN ALL FP= 9.15549E+09
 IN ALL GAS= 1.46663E+09
 IN HALOGENS= 7.74744E+09
 IN NOBLE GAS= 4.62985E+09
TOTAL BETA MEV/FISS=4.76562E+00
TOTAL GAMMA MEV/FISS=4.32949E+00
TOTAL BETA+GAMMA=9.59516E+00
FRACTION OF TOTALS IN GAS PRODUCTS
 BETA FRACTION=1.52071E-01
 GAMMA FRACTION=2.23519E-01
 TOTAL FRACTION=1.21534E-01
 FRACTIONAL DENSITY ALL GAS=1.55526E-01
 DENSITY OF RADIOACTIVE GAS=6.21935E-03
 FRACTIONAL GAS ACTIVITY=1.57799E-01

DECAY POWER IN MW FOR ALL FP IS
 TOTAL BETA MW=4.70729E+01
 TOTAL GAMMA MW=4.77769E+01
 TOTAL BETA+GAMMA MW=9.48497E+01
(MULTIPLY MEV/F BY 1.10352E+01 TO GET MW)

TABULAR VALUES ARE GIVEN AS FRACTIONS OF ALL NUCLIDES

NUCLIDE	DENSITY	CURIES	BETA MEV/F	GAMMA MEV/F	B+G MEV/F
Z A S					
35BR 83 0	2.21171E-07	7.54491E-04	2.91834E-04	6.25640E-06	1.43023E-04
35BR 84 0	8.33481E-09	1.28753E-03	1.86402E-03	2.56343E-03	2.21632E-03
35BR 84 1	7.56497E-10	6.19362E-05	6.39475E-05	1.94769E-04	1.29844E-04
35BR 85 0	8.90574E-09	1.52432E-03	1.74846E-03	1.11994E-04	9.24152E-04
36KR 85 1	8.59490E-07	1.57073E-03	4.09409E-04	3.26904E-04	3.67850E-04
35BR 86 0	1.87029E-09	1.00228E-03	2.75130E-03	3.77739E-03	2.92075E-03
35BR 86 1	9.44661E-11	6.18734E-04	2.27102E-03	1.17099E-03	1.68218E-03
35BR 87 0	4.36358E-09	2.30488E-03	5.67493E-03	4.51970E-03	5.09303E-03
36KR 87 0	4.50284E-07	2.91046E-03	4.47789E-03	2.62037E-03	3.54224E-03
35BR 88 0	9.26284E-10	1.71707E-03	6.07189E-03	3.66899E-03	4.96152E-03
36KR 89 0	1.42716E-06	4.17304E-03	1.13595E-03	1.04846E-02	5.87472E-03
35BR 89 0	5.73994E-11	3.75955E-04	1.22013E-03	8.46464E-04	1.03191E-03
36KR 89 0	3.15289E-08	4.90129E-03	7.01374E-03	1.14859E-02	9.26640E-03
36KR 90 0	4.44574E-09	4.05578E-03	5.55185E-03	8.06026E-03	6.81536E-03
36KR 91 0	4.89950E-10	1.65986E-03	4.93305E-03	1.36425E-03	3.13541E-03
53 I130 0	3.75729E-07	2.48071E-04	8.43709E-05	5.97393E-04	3.42796E-04
53 I131 0	1.64553E-06	4.99112E-03	1.42301E-03	3.08699E-03	2.29591E-03
53 I132 0	2.81350E-06	1.00909E-02	6.09799E-03	2.56240E-02	1.59335E-02
53 I133 0	3.52700E-05	1.38929E-02	6.67725E-03	9.44456E-03	8.07117E-03
54XE133 0	2.17750E-06	1.40415E-02	1.64929E-03	1.29897E-03	1.47283E-03
53 I134 0	1.59095E-06	1.48590E-02	1.19356E-02	4.37567E-02	2.79146E-02
53 I134 1	1.18146E-09	1.61216E-03	0.	5.78135E-04	2.91213E-04

53 I135 0	1.03526E-05	1.29714E-02	5.94159E-03	2.12890E-02	1.36221E-02
54XE135 0	2.81528E-06	2.51358E-03	8.99039E-04	7.46442E-04	8.21677E-04
54XE135 1	8.82765E-08	2.83428E-03	0.	1.69510E-03	8.54345E-04
53 I136 0	1.56096E-09	5.54313E-03	1.15739E-02	1.39373E-02	1.27643E-02
53 I136 1	4.77935E-09	2.93472E-03	6.56759E-03	6.41868E-03	6.48910E-03
53 I137 0	3.65991E-09	4.39505E-03	7.65714E-03	1.01046E-02	8.88995E-03
54XE137 0	9.19293E-08	1.17607E-02	2.49547E-02	2.60835E-03	1.36995E-02
53 I133 0	2.25554E-10	1.02277E-03	2.50170E-03	3.13809E-03	2.82225E-03
54XE138 0	3.14584E-07	1.08927E-02	8.25201E-03	1.47732E-02	1.15368E-02
53 I139 0	6.34112E-12	7.78745E-05	1.57224E-04	2.18733E-04	1.88208E-04
54XE139 0	9.65671E-09	7.04510E-03	1.45129E-02	7.42239E-03	1.09413E-02
54XE140 0	1.47905E-09	3.20542E-03	3.25482E-03	4.96064E-03	4.11406E-03
TOTAL GAS	2.24027E+03	1.44463E+09	6.78546E-01	9.67721E-01	1.64627E+00
	8.95720E+01	(RADIODACTIVE GAS DENSITY)			
TOTAL FP	1.44045E+04	9.15549E+09	4.25559E+00	4.32948E+00	8.59516E+00
TOTAL GAS FRACTIONS	1.55526E-01	1.57789E-01	1.59071E-01	2.23519E-01	1.91534E-01
	6.21835E-03 (RADIODACTIVE FRACTION OF TOTAL FP)				
NOBLE GAS FRACTIONS	1.48297E-01	7.31474E-02	7.73234E-02	6.82010E-02	7.27284E-02
	1.16532E-03 (NOBLE RADIODACTIVE GAS FRACTION OF TOTAL FP)				

TABLE C-XXXIV

TMI-2 IF OPERATED 26K MWS AT 2772, MW CONT. CINDER-10(LASL)8/79

CONTENT OF NOBLE GASES AND HALOGENS
(EXCEEDING 1.00000E-02 PERCENT OF TOTAL GAS)

TIME STEP 26
 ELAPSED TIME=9.34917E+07 SEC
 COOLING TIME=4.00000E+01 SEC
 TOTAL ACTIVITY=2.95022E+20
 CURIES IN ALL FP= 7.97356E+09
 IN ALL GAS= 1.26643E+03
 IN HALOGENS= 6.91978E+08
 IN NOBLE GAS= 5.74549E+08
 TOTAL BETA MEV/FISS=3.30204E+00
 TOTAL GAMMA MEV/FISS=3.57884E+00
 TOTAL BETA+GAMMA=6.88089E+00
 FRACTION OF TOTALS IN GAS PRODUCTS
 BETA FRACTION=1.55006E-01
 GAMMA FRACTION=2.28921E-01
 TOTAL FRACTION=1.93450E-01
 FRACTIONAL DENSITY ALL GAS=1.55526E-01
 DENSITY OF RADIODACTIVE GAS=6.21831E-03
 FRACTIONAL GAS ACTIVITY=1.58828E-01

DECAY POWER IN MW FOR ALL FP IS
 TOTAL BETA MW=3.64390E+01
 TOTAL GAMMA MW=3.94933E+01
 TOTAL BETA+GAMMA MW=7.59323E+01
 (MULTIPLY MEV/F BY 1.10352E+01 TO GET MW)

TABULAR VALUES ARE GIVEN AS FRACTIONS OF ALL NUCLIDES

NUCLIDE	DENSITY	CURTIS	BETA MEV/F	GAMMA MEV/F	B+G MEV/F
Z A S					
358R 83 0	2.21109E-07	8.66088E-04	3.63979E-04	7.56653E-06	1.78604E-04
358R 84 0	8.32402E-09	1.47647E-03	2.47488E-03	3.09708E-03	2.76490E-03
358R 84 1	7.14038E-10	6.71255E-05	7.79726E-05	2.22396E-04	1.53089E-04
358R 85 0	8.32874E-09	1.62687E-03	2.11235E-03	1.26706E-04	1.07960E-03
36KR 85 1	8.59425E-07	1.80342E-03	5.28844E-04	3.95440E-04	4.59459E-04
358R 86 0	1.41687E-09	8.71843E-04	2.00750E-03	3.46184E-03	2.76392E-03
358R 86 1	2.52126E-11	1.99616E-04	7.58975E-04	3.78084E-04	5.60821E-04
358R 87 0	3.05304E-09	1.85168E-03	5.12225E-03	3.82553E-03	4.45117E-03
36KR 87 0	4.49605E-07	3.33683E-03	5.77594E-03	3.16519E-03	4.41806E-03
358R 88 0	2.50536E-10	5.33263E-04	2.12155E-03	1.20051E-03	1.64250E-03
36KR 88 0	1.42490E-06	4.78401E-03	1.54251E-03	1.26635E-02	7.32667E-03
36KR 89 0	2.83060E-08	5.05253E-03	9.13436E-03	1.24746E-02	1.03919E-02
36KR 90 0	2.33577E-09	2.44735E-03	3.76914E-03	5.12304E-03	4.47294E-03
36KR 91 0	4.48866E-11	1.74409E-04	5.83828E-04	1.51200E-04	3.58813E-04
53 I130 0	3.75659E-07	2.84709E-04	1.09972E-04	7.22557E-04	4.28105E-04
53 I131 0	1.64553E-04	8.01593E-03	1.92871E-03	3.73446E-03	2.86790E-03
53 I132 0	2.81337E-06	1.15746E-02	7.87719E-03	3.09971E-02	1.99021E-02
53 I133 0	3.52688E-05	1.59402E-02	8.62553E-03	1.14251E-02	1.00816E-02
54XE133 0	2.17750E-04	1.61229E-02	2.13060E-03	1.57142E-03	1.83976E-03
54XE133 1	4.25339E-06	7.47112E-04	0.	2.08053E-04	1.08211E-04
53 I134 0	1.58862E-06	1.70354E-02	1.52671E-02	5.28566E-02	3.48179E-02
53 I134 1	1.07303E-08	1.68123E-03	0.	6.35204E-04	3.30377E-04
53 I135 0	1.03450E-05	1.47686E-02	7.54080E-03	2.57342E-02	1.70034E-02
54XE135 0	2.92323E-06	2.89432E-03	1.16339E-03	9.05554E-04	1.02929E-03
54XE135 1	8.76205E-08	3.23022E-03	0.	2.03660E-03	1.05926E-03
53 I136 0	1.29610E-08	5.28480E-03	1.24143E-02	1.39997E-02	1.32389E-02
53 I136 1	3.09902E-09	2.18501E-03	5.49544E-03	5.03495E-03	5.25593E-03
53 I137 0	1.57989E-09	2.17350E-03	4.27000E-03	5.27678E-03	4.79364E-03
54XE137 0	8.59843E-08	1.26154E-02	3.01201E-02	2.94798E-03	1.59876E-02
53 I139 0	9.21630E-12	4.79857E-05	1.32052E-04	1.55119E-04	1.44049E-04
54XE138 0	3.07208E-07	1.22029E-02	1.04102E-02	1.74527E-02	1.40731E-02
54XE139 0	5.77517E-09	4.83785E-03	1.12122E-02	5.36998E-03	8.17358E-03
54XE140 0	3.20588E-10	7.97707E-04	9.11370E-04	1.30075E-03	1.11389E-03
TOTAL GAS	2.24027E+03	1.26643E+09	5.11938E-01	8.19270E-01	1.33111E+00
	8.95715E+01	(RADIOACTIVE GAS DENSITY)			
TOTAL FP	1.44045E+04	7.97356E+09	3.30206E+00	3.57884E+00	6.88089E+00
TOTAL GAS FRACTIONS	1.55526E-01	1.58828E-01	1.55036E-01	2.28921E-01	1.93450E-01
	6.21931E-03	(RADIOACTIVE FRACTION OF TOTAL FP)			
NOBLE GAS FRACTIONS	1.48297E-01	7.20569E-02	7.63119E-02	6.58192E-02	7.08545E-02
	1.16530E-03	(NOBLE RADIOACTIVE GAS FRACTION OF TOTAL FP)			

TABLE C-XXXV

TMI-2 IF OPERATED 25K HRS AT 2777. MW CONT. CINDER-10(LASL)8/79

CONTENT OF NOBLE GASES AND HALOGENS
(EXCEEDING 1.00000E-02 PERCENT OF TOTAL GAS)

TIME STEP 27
ELAPSED TIME=9.34917E+07 SEC
COOLING TIME=1.00000E+02 SEC
TOTAL ACTIVITY=2.57443E+20
CURIES IN ALL FP= 7.17602E+09

IN ALL GAS= 1.12910E+09
IN HALOGENS= 6.29372E+09

IN NOBLE GAS= 4.99728E+09
TOTAL BETA MEV/FISS=2.67754E+00
TOTAL GAMMA MEV/FISS=3.03673E+00
TOTAL BETA+GAMMA=5.71427E+00
FRACTION OF TOTALS IN GAS PRODUCTS
BETA FRACTION=1.46379E-01
GAMMA FRACTION=2.33807E-01
TOTAL FRACTION=1.92941E-01
FRACTIONAL DENSITY ALL GAS=1.55526E-01
DENSITY OF RADIOACTIVE GAS=6.21824E-03
FRACTIONAL GAS ACTIVITY=1.58447E-01

DECAY POWER IN MW FOR ALL FP IS
TOTAL BETA MW=2.95474E+01
TOTAL GAMMA MW=3.35110E+01
TOTAL BETA+GAMMA MW=6.30584E+01
(MULTIPLY MEV/F BY 1.10352E+01 TO GET MW)

TABULAR VALUES ARE GIVEN AS FRACTIONS OF ALL NUCLIDES

NUCLIDE	DENSITY	CURIES	BETA MEV/F	GAMMA MEV/F	B+G MEV/F
Z A S					
358R 83 0	2.20809E-07	9.67782E-04	4.48264E-04	8.90518E-06	2.14776E-04
358R 84 0	8.27997E-09	1.64333E-03	2.95710E-03	3.63066E-03	3.31176E-03
358R 94 1	6.36135E-10	5.69147E-05	8.55478E-05	2.33502E-04	1.64231E-04
358R 95 0	6.85340E-09	1.50712E-03	2.14259E-03	1.22874E-04	1.06973E-03
36KR 85 1	8.59045E-07	2.01702E-03	6.51903E-04	4.65827E-04	5.53017E-04
358R 86 0	7.02734E-10	4.83842E-04	1.22790E-03	2.02350E-03	1.65070E-03
358R 87 0	1.44973E-09	9.93848E-04	3.00371E-03	2.14084E-03	2.54515E-03
36KR 97 0	4.47119E-07	3.71307E-03	7.08374E-03	3.70962E-03	5.29064E-03
358R 88 0	1.83191E-11	4.36297E-05	1.91309E-04	1.03451E-04	1.44619E-04
36KR 88 0	1.41926E-06	5.33183E-03	1.89474E-03	1.48651E-02	8.78758E-03
36KR 89 0	2.27313E-09	4.54004E-03	9.05595E-03	1.18062E-02	1.00489E-02
36KR 90 0	6.44523E-10	7.55633E-04	1.28228E-03	1.66599E-03	1.48620E-03
53 I130 0	3.75506E-07	3.18532E-04	1.34334E-04	8.51200E-04	5.15297E-04
53 I131 0	1.64553E-04	8.96932E-03	2.37856E-03	4.40113E-03	3.45341E-03
53 I132 0	2.81311E-06	1.29501E-02	7.71354E-03	3.65272E-02	2.39631E-02
53 I133 0	3.52657E-05	1.78345E-02	1.06364E-02	1.34635E-02	1.21388E-02
54XE133 0	2.17750E-04	1.80405E-02	2.62754E-03	1.85195E-03	2.21537E-03
54XE133 1	4.25333E-06	8.25953E-04	0.	2.45191E-04	1.30302E-04
53 I134 0	1.58353E-05	1.90005E-02	1.87477E-02	6.20931E-02	4.17921E-02
53 I134 1	8.85098E-09	1.55172E-03	0.	6.17489E-04	3.28151E-04
53 I135 0	1.03275E-05	1.64971E-02	9.28389E-03	3.02769E-02	2.04402E-02

54XE135 0	2.83906E-06	3.25672E-03	1.44279E-03	1.07319E-03	1.24637E-03
54XE135 1	8.63489E-08	3.56195E-03	0.	2.36534E-03	1.25701E-03
53 I136 0	8.19907E-09	3.74077E-03	9.49497E-03	1.04371E-02	1.00847E-02
53 I136 1	1.30297E-09	1.02794E-03	2.84945E-03	2.49484E-03	2.66100E-03
53 I137 0	2.91354E-10	4.48497E-04	9.71111E-04	1.14683E-03	1.06449E-03
54XE137 0	7.27887E-08	1.19534E-02	3.14815E-02	2.94450E-03	1.63161E-02
54XE138 0	2.92580E-07	1.30041E-02	1.22270E-02	1.95890E-02	1.61394E-02
54XE139 0	2.06296E-09	1.93357E-03	4.93927E-03	2.26066E-03	3.51578E-03
TOTAL GAS	2.24027E+03	1.12910E+09	3.91935E-01	7.10009E-01	1.10194E+00
	9.95704E+01	(RADIOACTIVE GAS DENSITY)			
TOTAL FP	1.44045E+04	7.12502E+09	2.67754E+00	3.03673E+00	5.71427E+00
TOTAL GAS FRACTIONS	1.55525E-01	1.58447E-01	1.45379E-01	2.33807E-01	1.92841E-01
	6.21824E-03	(RADIOACTIVE FRACTION OF TOTAL FP)			
NOBLE GAS FRACTIONS	1.48297E-01	7.01272E-02	7.17830E-02	6.29788E-02	6.71042E-02
	1.16526E-03	(NOBLE RADIOACTIVE GAS FRACTION OF TOTAL FP)			

TABLE C-XXXVI

TMI-2 IF OPERATED 26K HRS AT 2772. MW CONT. CINDER-10(LASL)8/79

CONTENT OF NOBLE GASES AND HALOGENS
(EXCEEDING 1.00000E-02 PERCENT OF TOTAL GAS)

TIME STEP 29
 ELAPSED TIME=9.34920E+07 SEC
 COOLING TIME=4.00000E+02 SEC
 TOTAL ACTIVITY=2.19494E+20
 CURIES IN ALL FP= 5.93200E+09
 IN ALL GAS= 9.42370E+08
 IN HALOGENS= 5.64175E+08
 IN NOBLE GAS= 3.85195E+08
 TOTAL BETA MEV/FISS=1.91025E+09
 TOTAL GAMMA MEV/FISS=2.34765E+00
 TOTAL BETA+GAMMA=4.25790E+00
 FRACTION OF TOTALS IN GAS PRODUCTS
 BETA FRACTION=1.31627E-01
 GAMMA FRACTION=2.53079E-01
 TOTAL FRACTION=1.98591E-01
 FRACTIONAL DENSITY ALL GAS=1.55526E-01
 DENSITY OF RADIOACTIVE GAS=6.21798E-03
 FRACTIONAL GAS ACTIVITY=1.60042E-01

DECAY POWER IN MW FPD ALL FP IS
 TOTAL BETA MW=2.10901E+01
 TOTAL GAMMA MW=2.59049E+01
 TOTAL BETA+GAMMA MW=4.69870E+01
 (MULTIPLY MEV/F BY 1.10352E+01 TO GET MW)

TABULAR VALUES ARE GIVEN AS FRACTIONS OF ALL NUCLIDES

NUCLIDE	DENSITY	CURIES	BETA MEV/F	GAMMA MEV/F	B+G MEV/F
Z A S					
35BR 83 0	2.17821E-07	1.14685E-03	5.19816E-04	1.13631E-05	2.84338E-04
35BR 84 0	7.78258E-08	1.85552E-03	3.98667E-03	4.41420E-03	4.17753E-03

35BR 84 1	3.57017E-10	4.51137E-05	6.73916E-05	1.69514E-04	1.23698E-04
35BR 85 0	2.10955E-09	5.57310E-04	9.24996E-04	4.89256E-05	4.41919E-04
36KR 85 1	8.52907E-07	2.40570E-03	9.07226E-04	5.98250E-04	7.36868E-04
36KR 87 0	4.28555E-07	4.27525E-03	9.51483E-03	4.59922E-03	6.80544E-03
36KR 89 0	1.39030E-06	5.27434E-03	2.60164E-03	1.88359E-02	1.15526E-02
36KR 89 0	7.59121E-09	1.82135E-03	3.77095E-03	5.09997E-03	4.50372E-03
53 I130 0	3.74545E-07	3.81659E-04	1.87911E-04	1.09822E-03	6.89779E-04
53 I131 0	1.64552E-04	1.07746E-02	3.33395E-03	5.69291E-03	4.63459E-03
53 I132 0	2.81178E-06	1.55474E-02	1.34789E-02	4.72263E-02	3.21443E-02
53 I133 0	3.52439E-05	2.14110E-02	1.48996E-02	1.74045E-02	1.62807E-02
54XE133 0	2.17750E-04	2.16718E-02	3.68296E-03	2.39553E-03	2.97312E-03
54XE133 1	4.25302E-06	1.00415E-03	0.	3.17136E-04	1.74857E-04
53 I134 0	1.55200E-06	2.23704E-02	2.57823E-02	7.87189E-02	5.49696E-02
53 I134 1	3.37982E-09	7.11804E-04	0.	3.05003E-04	1.68167E-04
53 I135 0	1.07374E-05	1.96448E-02	1.28994E-02	3.88220E-02	2.71922E-02
54XE135 0	2.91668E-06	4.01920E-03	2.07759E-03	1.42615E-03	1.71841E-03
54XE135 1	8.07225E-08	4.00011E-03	0.	2.86025E-03	1.57704E-03
53 I136 0	6.77762E-10	3.71456E-04	1.12217E-03	1.11600E-03	1.11877E-03
54XE137 0	2.96439E-08	5.95291E-03	1.79710E-02	1.55115E-03	8.91769E-03
54XE138 0	2.29218E-07	1.22385E-02	1.34247E-02	1.98513E-02	1.69690E-02
TOTAL GAS	2.24027E+03	9.49370E+08	2.51440E-01	5.94141E-01	8.45581E-01
	8.95666E+01	(RADIODACTIVE GAS DENSITY)			
TOTAL FP	1.44045E+04	5.93200E+09	1.91025E+00	2.34765E+00	4.25790E+00
TOTAL GAS FRACTIONS	1.55524E-01	1.60042E-01	1.31627E-01	2.53079E-01	1.98591E-01
	6.21798E-03	(RADIODACTIVE FRACTION OF TOTAL FP)			
NOBLE GAS FRACTIONS	1.48298E-01	6.49350E-02	5.40504E-02	5.76365E-02	5.60277E-02
	1.16516E-03	(NOBLE RADIODACTIVE GAS FRACTION OF TOTAL FP)			

TABLE C-XXXVII

TMI-2 IF OPERATED 26K HPS AT 2772. MW CONT. CINDER-10(LASL)8/79

CONTENT OF NOBLE GASES AND HALOGENS
(EXCEEDING 1.00000E-02 PERCENT OF TOTAL GAS)

TIME STEP 29
 ELAPSED TIME=9.34926E+07 SEC
 COOLING TIME=1.00000E+03 SEC
 TOTAL ACTIVITY=1.91487E+20
 CURIES IN ALL FP= 5.17533E+09
 IN ALL GAS= 9.56053E+08
 IN HALOGENS= 5.42895E+08
 IN NOBLE GAS= 3.13157E+09
 TOTAL BETA MEV/FISS=1.50029E+00
 TOTAL GAMMA MEV/FISS=1.96046E+00
 TOTAL BETA+GAMMA=3.46074E+00
 FRACTION OF TOTALS IN GAS PRODUCTS
 BETA FRACTION=1.30730E-01
 GAMMA FRACTION=2.76456E-01
 TOTAL FRACTION=2.13282E-01
 FRACTIONAL DENSITY ALL GAS=1.55526E-01
 DENSITY OF RADIODACTIVE GAS=6.21755E-03
 FRACTIONAL GAS ACTIVITY=1.65410E-01

DECAY POWER IN MW FOR ALL FP IS
 TOTAL BETA MW=1.55560E+01
 TOTAL GAMMA MW=2.14342E+01
 TOTAL BETA+GAMMA MW=3.81901E+01
 (MULTIPLY MEV/F BY 1.10352E+01 TO GET MW)

TABULAR VALUES ARE GIVEN AS FRACTIONS OF ALL NUCLIDES

NUCLIDE	DENSITY	CURIES	BETA MEV/F	GAMMA MEV/F	B+G MEV/F
Z A S					
35BR 82 0	1.29586E-07	5.26105E-05	1.36479E-05	1.97696E-04	1.17909E-04
35BR 83 0	2.10519E-07	1.27046E-03	7.62734E-04	1.31512E-05	3.38106E-04
35BR 84 0	6.41430E-08	1.75289E-03	4.07869E-03	4.35665E-03	4.23615E-03
36KR 85 1	8.33082E-07	2.62334E-03	1.12829E-03	6.99753E-04	8.85528E-04
36KR 87 0	3.91231E-07	4.47354E-03	1.10521E-02	5.02789E-03	7.64379E-03
36KR 88 0	1.33411E-06	6.92102E-03	3.17867E-03	2.16443E-02	1.36392E-02
36KR 89 0	8.46608E-10	2.32824E-04	5.35475E-04	6.81105E-04	6.17972E-04
53 I130 0	3.71960E-07	4.34451E-04	2.37481E-04	1.30604E-03	8.42807E-04
53 I131 0	1.64546E-04	1.23495E-02	4.24483E-03	6.81700E-03	5.70193E-03
53 I132 0	2.90910E-06	1.79058E-02	1.73110E-02	5.64995E-02	3.95107E-02
53 I133 0	3.51680E-05	2.44887E-02	1.89302E-02	2.07970E-02	1.99877E-02
54XE133 0	2.17751E-04	2.48405E-02	4.68938E-03	2.86866E-03	3.65797E-03
54XE133 1	4.25238E-06	1.15079E-03	0.	3.79712E-04	2.15102E-04
53 I134 0	1.47276E-06	2.43321E-02	3.11515E-02	8.94531E-02	6.41785E-02
53 I135 0	1.00594E-05	2.21254E-02	1.61387E-02	4.56808E-02	3.28739E-02
54XE135 0	3.06523E-06	4.84148E-03	2.78005E-03	1.79479E-03	2.22191E-03
54XE135 1	7.23708E-08	4.11059E-03	0.	3.07077E-03	1.73955E-03
54XE137 0	4.87531E-09	1.12332E-03	3.75319E-03	3.05490E-04	1.80445E-03
54XE138 0	1.40687E-07	8.60992E-03	1.04228E-02	1.45905E-02	1.28141E-02
TOTAL GAS	2.24027E+03	8.56053E+08	1.96132E-01	5.41981E-01	7.38113E-01
	8.95605E+01	(RADIOACTIVE GAS DENSITY)			
TOTAL FP	1.44045E+04	5.17533E+09	1.50028E+00	1.96046E+00	3.46074E+00
TOTAL GAS FRACTIONS	1.55526E-01	1.65410E-01	1.30730E-01	2.76456E-01	2.13282E-01
	6.21755E-03	(RADIOACTIVE FRACTION OF TOTAL FP)			
NOBLE GAS FRACTIONS	1.48298E-01	6.05097E-02	3.76969E-02	5.11600E-02	4.53235E-02
	1.16507E-03	(NOBLE RADIOACTIVE GAS FRACTION OF TOTAL FP)			

TABLE C-XXXVIII

TMI-2 IF OPERATED 26K HRS AT 2772. MW CONT. CINDER-10(LASL)8/79

CONTENT OF NOBLE GASES AND HALOGENS
(EXCEEDING 1.00000E-02 PERCENT OF TOTAL GAS)

TIME STEP 30
 ELAPSED TIME=9.36952E+07 SEC
 COOLING TIME=3.60000E+03 SEC
 TOTAL ACTIVITY=1.52317E+20
 CURIES IN ALL FP= 4.11550E+09
 IN ALL GAS= 7.42203E+09
 IN HALOGENS= 4.00096E+09
 IN NOBLE GAS= 2.52107E+09
 TOTAL BETA MEV/FISS=1.00974E+00
 TOTAL GAMMA MEV/FISS=1.36256E+00
 TOTAL BETA+GAMMA=2.37130E+00
 FRACTION OF TOTALS IN GAS PRODUCTS
 BETA FRACTION=1.4980E-01

GAMMA FRACTION=3.25578E-01
 TOTAL FRACTION=2.50837E-01
 FRACTIONAL DENSITY ALL GAS=1.55526E-01
 DENSITY OF RADIOACTIVE GAS=4.21576E-03
 FRACTIONAL GAS ACTIVITY=1.00000E-01

DECAY POWER IN MW FOR ALL FP IS
 TOTAL BETA MW=1.11317E+01
 TOTAL GAMMA MW=1.50362E+01
 TOTAL BETA+GAMMA MW=2.61679E+01
 (MULTIPLY MEV/F BY 1.10352E+01 TO GET MW)

TABULAR VALUES ARE GIVEN AS FRACTIONS OF ALL NUCLIDES

NUCLIDE	DENSITY	CURIES	BETA MEV/F	GAMMA MEV/F	B+G MEV/F
Z A S					
359R 82 0	1.26923E-07	6.52360E-05	2.00201E-05	2.80547E-04	1.69720E-04
359R 83 0	1.76269E-07	1.33739E-03	9.49844E-04	1.58436E-05	4.13162E-04
359R 84 0	2.50514E-08	8.60691E-04	2.35019E-03	2.44815E-03	2.41455E-03
36KR 85 1	7.45175E-07	3.02890E-03	1.50101E-03	9.00569E-04	1.15599E-03
36KR 87 0	2.63507E-07	3.79810E-03	1.10813E-02	4.87246E-03	7.51367E-03
36KR 88 0	1.11569E-04	7.25566E-03	3.95261E-03	2.60435E-02	1.66466E-02
53 I130 0	3.57952E-07	5.25631E-04	3.39902E-04	1.80838E-03	1.18370E-03
53 I131 0	1.64425E-04	1.55145E-02	6.30861E-03	9.80109E-03	8.31541E-03
53 I132 0	2.79674E-06	2.22873E-02	2.56332E-02	8.09342E-02	5.74094E-02
53 I133 0	3.45920E-05	3.02833E-02	2.76935E-02	2.94327E-02	2.86929E-02
54XE133 0	2.17747E-04	3.12293E-02	6.97432E-03	4.12737E-03	5.33845E-03
54XE133 1	4.24925E-04	1.44573E-03	0.	5.45931E-04	3.13695E-04
53 I134 0	1.07834E-06	2.23983E-02	3.39234E-02	9.42374E-02	6.85802E-02
53 I135 0	9.32300E-06	2.57802E-02	2.22457E-02	6.09145E-02	4.44650E-02
54XE135 0	3.63301E-06	7.21427E-03	4.90061E-03	3.06070E-03	3.84339E-03
54XE135 1	5.70612E-08	4.07457E-03	0.	3.48359E-03	2.00169E-03
54XE138 0	1.69675E-08	1.30549E-03	1.99214E-03	2.53183E-03	2.25546E-03
TOTAL GAS	2.24027E+03	7.42203E+08	1.51189E-01	4.43620E-01	5.94809E-01
	8.95347E+01	(RADIOACTIVE GAS DENSITY)			
TOTAL FP	1.44045E+04	4.11550E+09	1.00974E+00	1.36256E+00	2.37130E+00

TOTAL GAS FRACTIONS 1.55526E-01 1.40300E-01 1.49810E-01 3.25578E-01 2.50837E-01
6.21576E-03 (RADIOACTIVE FRACTION OF TOTAL FP)

NOBLE GAS FRACTIONS 1.48300E-01 6.12432E-02 3.0394E-02 4.57023E-02 3.91906E-02
1.16506E-03 (NOBLE RADIOACTIVE GAS FRACTION OF TOTAL FP)

TABLE C-XXXIX

TMI-2 IF OPERATED 26K HRS AT 2772. MW CONT. CINDER-10(LASL)8/79

CONTENT OF NOBLE GASES AND HALOGENS
(EXCEEDING 1.00000E-02 PERCENT OF TOTAL GAS)

TIME STEP 31
ELAPSED TIME=9.34099E+07 SEC
COOLING TIME=7.20000E+03 SEC
TOTAL ACTIVITY=1.36000E+00
CURIES IN ALL FP= 3.67549E+09
IN ALL GAS= 6.66449E+09
IN HALOGENS= 4.31947E+09
IN NOBLE GAS= 2.34587E+09
TOTAL BETA MEV/FISS=8.27019E-01
TOTAL GAMMA MEV/FISS=1.07944E+00
TOTAL BETA+GAMMA=1.90546E+00
FRACTION OF TOTALS IN GAS PRODUCTS
BETA FRACTION=1.50737E-01
GAMMA FRACTION=3.35912E-01
TOTAL FRACTION=2.55541E-01
FRACTIONAL DENSITY ALL GAS=1.55526E-01
DENSITY OF RADIOACTIVE GAS=6.21322E-03
FRACTIONAL GAS ACTIVITY=1.81313E-01

DECAY POWER IN MW FOR ALL FP IS
TOTAL BETA MW=9.12636E+00
TOTAL GAMMA MW=1.19009E+01
TOTAL BETA+GAMMA MW=2.10272E+01
(MULTIPLY MEV/F BY 1.10352E+01 TO GET MW)

TABULAR VALUES ARE GIVEN AS FRACTIONS OF ALL NUCLIDES

NUCLIDE	DENSITY	CURIES	BETA MEV/F	GAMMA MEV/F	B+G MEV/F
Z A S					
35BR 82 0	1.24365E-07	7.16430E-05	2.39454E-05	3.47586E-04	2.07118E-04
35BR 83 0	1.33581E-07	1.13505E-03	9.77977E-04	1.51698E-05	3.89650E-04
35BR 84 0	6.77409E-09	2.60649E-04	7.81410E-04	8.36402E-04	8.12534E-04
36KR 85 1	6.38357E-07	2.90581E-03	1.56838E-03	9.74724E-04	1.23239E-03
36KR 87 0	1.52454E-07	2.45446E-03	7.91985E-03	3.56166E-03	5.40982E-03
36KR 88 0	8.71029E-07	6.34399E-03	3.76493E-03	2.56890E-02	1.61734E-02
53 I130 0	3.38517E-07	5.56704E-04	3.92077E-04	2.16075E-03	1.39310E-03
53 I131 0	1.64055E-04	1.73361E-02	7.67749E-03	1.23553E-02	1.03250E-02
53 I132 0	2.77799E-06	2.47927E-02	3.10559E-02	1.01571E-01	7.09655E-02
53 I133 0	3.36026E-05	3.29451E-02	3.29124E-02	3.61232E-02	3.46862E-02
54XE133 0	2.17716E-04	3.49695E-02	8.50555E-03	5.21398E-03	6.64261E-03
54XE133 1	4.24374E-06	1.61701E-03	0.	6.88863E-04	3.89879E-04
53 I134 0	6.19286E-07	1.44058E-02	2.37627E-02	6.83779E-02	4.90138E-02
53 I135 0	8.39154E-06	2.59873E-02	2.44728E-02	6.92732E-02	4.98070E-02
54XE135 0	4.27124E-06	2.49880E-03	7.02749E-03	4.54638E-03	5.62325E-03
54XE135 1	4.98692E-08	3.99816E-03	0.	3.84660E-03	2.17709E-03
54XE138 0	9.07108E-10	7.81633E-05	1.22731E-04	1.71015E-04	1.50059E-04

TOTAL GAS 2.24027E+03 6.66449E+08 1.24652E-01 3.62262E-01 4.86924E-01
8.94981E+01 (RADIOACTIVE GAS DENSITY)

TOTAL FP 1.44045E+04 3.67569E+09 8.27019E-01 1.07844E+00 1.90546E+00

TOTAL GAS FRACTIONS 1.55526E-01 1.81313E-01 1.50737E-01 3.35912E-01 2.55541E-01
6.21322E-03 (RADIOACTIVE FRACTION OF TOTAL FP)

NOBLE GAS FRACTIONS 1.48302E-01 6.39214E-02 2.89302E-02 4.48517E-02 3.79414E-02
1.16513E-03 (NOBLE RADIOACTIVE GAS FRACTION OF TOTAL FP)

TABLE C-XL

TMI-2 IF OPERATED 26K HRS AT 2772. MW CONT. CINDER-10(LASL)8/79

CONTENT OF NOBLE GASES AND HALOGENS
(EXCEEDING 1.00000E-02 PERCENT OF TOTAL GAS)

TIME STEP 32
ELAPSED TIME=9.35096E+07 SEC
COOLING TIME=1.90000E+04 SEC
TOTAL ACTIVITY=1.17989E+20
CURIES IN ALL FP= 3.18888E+09
IN ALL GAS= 5.54429E+08
IN HALOGENS= 3.42440E+09
IN NOBLE GAS= 2.13789E+09
TOTAL BETA MEV/FISS=5.44073E-01
TOTAL GAMMA MEV/FISS=9.12071E-01
TOTAL BETA+GAMMA=1.45914E+00
FRACTION OF TOTALS IN GAS PRODUCTS
BETA FRACTION=1.42499E-01
GAMMA FRACTION=3.11061E-01
TOTAL FRACTION=2.36375E-01
FRACTIONAL DENSITY ALL GAS=1.55524E-01
DENSITY OF RADIOACTIVE GAS=6.20614E-03
FRACTIONAL GAS ACTIVITY=1.74491E-01

DECAY POWER IN MW FOR ALL FP IS
TOTAL BETA MW=7.12957E+00
TOTAL GAMMA MW=8.96140E+00
TOTAL BETA+GAMMA MW=1.60910E+01
(MULTIPLY MEV/F BY 1.10352E+01 TO GET MW)

TABULAR VALUES ARE GIVEN AS FRACTIONS OF ALL NUCLIDES

NUCLIDE	DENSITY	CURIES	BETA MEV/F	GAMMA MEV/F	B+G MEV/F
Z A S					
35BR 82 0	1.17270E-07	7.78699E-05	2.99034E-05	4.35266E-04	2.55215E-04
35BR 83 0	5.63334E-09	5.51741E-04	4.73956E-04	8.49578E-06	2.14731E-04
36KR 85 1	4.01311E-07	2.10544E-03	1.26213E-03	8.13771E-04	1.01243E-03
36KR 87 0	2.95233E-09	5.47994E-04	1.93950E-03	9.15987E-04	1.36904E-03
36KR 88 0	4.14476E-07	3.47955E-03	2.29323E-03	1.62337E-02	1.00570E-02
53 I130 0	2.86255E-07	5.47624E-04	4.24403E-04	2.42650E-03	1.53941E-03
53 I131 0	1.62593E-04	1.98045E-02	9.74015E-03	1.62619E-02	1.33723E-02
53 I132 0	2.71489E-06	2.79285E-02	3.88509E-02	1.31824E-01	9.06295E-02

53 I133 0	3.05108E-05	3.44873E-02	3.81375E-02	4.35583E-02	4.11564E-02
54XE133 0	2.17424E-04	4.02539E-02	1.08731E-02	6.91499E-03	8.66876E-03
54XE133 1	4.21855E-06	1.85285E-03	0.	9.09415E-04	5.06472E-04
53 I134 0	8.25526E-08	2.21349E-03	4.05490E-03	1.21048E-02	8.53804E-03
53 I135 0	6.11927E-06	2.18434E-02	2.27975E-02	6.70852E-02	4.74622E-02
54XE135 0	5.43607E-06	1.39348E-02	1.14489E-02	7.68423E-03	9.35229E-03
54XE135 1	3.62795E-08	3.34428E-03	0.	3.71630E-03	2.06958E-03
TOTAL GAS	2.24024E+03	5.56429E+08	9.20648E-02	2.52604E-01	3.44669E-01
	9.93962E+01	(RADIOACTIVE GAS DENSITY)			
TOTAL FP	1.44045E+04	3.18888E+09	6.46073E-01	8.12071E-01	1.45814E+00
TOTAL GAS FRACTIONS	1.55524E-01	1.74491E-01	1.42499E-01	3.11061E-01	2.36375E-01
	6.20614E-03	(RADIOACTIVE FRACTION OF TOTAL FP)			
NOBLE GAS FRACTIONS	1.48307E-01	6.70422E-02	2.79713E-02	3.73348E-02	3.31860E-02
	1.16516E-03	(NOBLE RADIOACTIVE GAS FRACTION OF TOTAL FP)			

TABLE C-XLI

THI-2 IF OPERATED 26K HRS AT 2772. MW CONT. CINDER-10(LASL)8/79

CONTENT OF NOBLE GASES AND HALOGENS
(EXCEEDING 1.00000E-02 PERCENT OF TOTAL GAS)

TIME STEP 33
 ELAPSED TIME=9.35274E+07 SEC
 COOLING TIME=3.60000E+04 SEC
 TOTAL ACTIVITY=1.04429E+20
 CURIES IN ALL FP= 2.82240E+09
 IN ALL GAS= 4.79919E+08
 IN HALOGENS= 2.83925E+08
 IN NOBLE GAS= 1.95894E+08
 TOTAL BETA MEV/FISS=5.25728E-01
 TOTAL GAMMA MEV/FISS=6.81521E-01
 TOTAL BETA+GAMMA=1.20725E+00
 FRACTION OF TOTALS IN GAS PRODUCTS
 BETA FRACTION=1.44620E-01
 GAMMA FRACTION=2.91654E-01
 TOTAL FRACTION=2.27624E-01
 FRACTIONAL DENSITY ALL GAS=1.55521E-01
 DENSITY OF RADIOACTIVE GAS=6.12530E-03
 FRACTIONAL GAS ACTIVITY=1.70004E-01

DECAY POWER IN MW FOR ALL FP IS
 TOTAL BETA MW=5.80154E+00
 TOTAL GAMMA MW=7.52075E+00
 TOTAL BETA+GAMMA MW=1.33223E+01
 (MULTIPLY MEV/F BY 1.10352E+01 TO GET MW)

TABULAR VALUES ARE GIVEN AS FRACTIONS OF ALL NUCLIDES

NUCLIDE	DENSITY	CURIES	BETA MEV/F	GAMMA MEV/F	B+G MEV/F
35BR 82 0	1.06333E-07	7.97744E-05	3.22070E-05	4.70273E-04	2.79506E-04
36KR 85 1	1.85144E-07	1.09757E-03	7.15571E-04	4.47348E-04	5.64153E-04
36KR 87 0	1.91379E-09	4.01266E-05	1.54422E-04	7.07501E-05	1.07197E-04
36KR 88 0	1.20211E-07	1.14022E-03	9.17359E-04	5.51020E-03	3.52303E-03
53 I130 0	2.16458E-07	4.53525E-04	3.94394E-04	2.18633E-03	1.40598E-03
53 I131 0	1.60081E-04	2.20303E-02	1.17849E-02	1.90776E-02	1.59018E-02
53 I132 0	2.60209E-06	3.02438E-02	4.57604E-02	1.50549E-01	1.04916E-01
53 I133 0	2.58393E-05	3.29227E-02	3.24217E-02	4.39555E-02	4.20987E-02
54XE133 0	2.16318E-04	4.52492E-02	1.32941E-02	8.19766E-03	1.04170E-02
54XE133 1	4.15114E-04	2.05922E-03	0.	1.06628E-03	6.01938E-04
53 I134 0	1.95047E-09	5.90889E-05	1.17733E-04	3.40786E-04	2.43652E-04
53 I135 0	3.61518E-04	1.45804E-02	1.65515E-02	4.72249E-02	3.38674E-02
54XE135 0	5.78675E-06	1.67598E-02	1.49774E-02	9.74686E-03	1.20246E-02
54XE135 1	2.14334E-09	2.23229E-03	0.	2.61610E-03	1.47685E-03
TOTAL GAS	2.24019E+03	4.79819E+08	7.60309E-02	1.98768E-01	2.74799E-01
	8.92399E+01	(RADIOACTIVE GAS DENSITY)			
TOTAL FP	1.44045E+04	2.82240E+09	5.25729E-01	6.81521E-01	1.20725E+00
TOTAL GAS FRACTIONS	1.55521E-01	1.70204E-01	1.44420E-01	2.91654E-01	2.27624E-01
	6.19530E-03	(RADIOACTIVE FRACTION OF TOTAL FP)			
NOBLE GAS FRACTIONS	1.48313E-01	5.94068E-02	3.01497E-02	2.78465E-02	2.88495E-02
	1.16374E-03	(NOBLE RADIOACTIVE GAS FRACTION OF TOTAL FP)			

TABLE C-XLII

TMI-2 IF OPERATED 26K HRS AT 2772. MW CONT. CINDER-10(LASL)8/79

CONTENT OF NOBLE GASES AND HALOGENS
(EXCEEDING 1.00000E-02 PERCENT OF TOTAL GAS)

TIME STEP 34
 ELAPSED TIME=9.35634E+07 SEC
 COOLING TIME=7.20000E+04 SEC
 TOTAL ACTIVITY=9.03349E+19
 CURIES IN ALL FP= 2.44153E+09
 IN ALL GAS= 3.20513E+09
 IN HALOGENS= 2.20426E+09
 IN NOBLE GAS= 1.70086E+09
 TOTAL BETA MEV/FISS=4.21101E-01
 TOTAL GAMMA MEV/FISS=5.74940E-01
 TOTAL BETA+GAMMA=9.95941E-01
 FRACTION OF TOTALS IN GAS PRODUCTS
 BETA FRACTION=1.40203E-01
 GAMMA FRACTION=2.65227E-01
 TOTAL FRACTION=2.12365E-01
 FRACTIONAL DENSITY ALL GAS=1.55514E-01
 DENSITY OF RADIOACTIVE GAS=6.17486E-03
 FRACTIONAL GAS ACTIVITY=1.59946E-01

DECAY POWER IN MW FOR ALL FP IS
 TOTAL BETA MW=4.54695E+00
 TOTAL GAMMA MW=6.34350E+00
 TOTAL BETA+GAMMA MW=1.07905E+01
 (MULTIPLY MEV/F BY 1.10352E+01 TO GET MW)

TABULAR VALUES ARE GIVEN AS FRACTIONS OF ALL NUCLIDES

NUCLIDE	DENSITY	CURIES	BETA MEV/F	GAMMA MEV/F	B+G MEV/F
Z A S					
35BR 82 0	8.74240E-08	7.58197E-05	3.30599E-05	4.58402E-04	2.78559E-04
36KR 85 0	9.35626E-04	3.05399E-04	2.38339E-04	1.55373E-06	1.01670E-04
36KR 85 1	3.94065E-08	2.70051E-04	1.90145E-04	1.12885E-04	1.45552E-04
36KR 88 0	1.01120E-08	1.10975E-04	9.59379E-05	5.59503E-04	3.59229E-04
53 I130 0	1.23770E-07	3.04434E-04	2.91537E-04	1.48214E-03	9.74505E-04
53 I131 0	1.55070E-04	2.46697E-02	1.42523E-02	2.19100E-02	1.86722E-02
53 I132 0	2.38217E-06	3.20068E-02	5.23016E-02	1.63404E-01	1.16429E-01
53 I133 0	1.95166E-05	2.73309E-02	3.55103E-02	3.73444E-02	3.65689E-02
54XE133 0	2.12239E-04	5.13214E-02	1.62841E-02	9.53572E-03	1.23891E-02
54XE133 1	3.94439E-06	2.26266E-03	0.	1.20120E-03	6.93310E-04
53 I135 0	1.26190E-06	5.88291E-03	7.21229E-03	1.95417E-02	1.43286E-02
54XE135 0	4.27159E-04	1.43014E-02	1.39027E-02	8.53006E-03	1.07594E-02
54XE135 1	7.48086E-09	9.00672E-04	0.	1.08255E-03	6.24827E-04
TOTAL GAS	2.24010E+03	3.90513E+08	5.90395E-02	1.52463E-01	2.11503E-01
	8.89455E+01	(RADIOACTIVE GAS DENSITY)			
TOTAL FP	1.44045E+04	2.44153E+09	4.21101E-01	5.74840E-01	9.95941E-01
TOTAL GAS FRACTIONS	1.55514E-01	1.59946E-01	1.40203E-01	2.65227E-01	2.12365E-01
	6.17486E-03	(RADIOACTIVE FRACTION OF TOTAL FP)			
NOBLE GAS FRACTIONS	1.48320E-01	6.96639E-02	3.06020E-02	2.10866E-02	2.51099E-02
	1.15760E-03	(NOBLE RADIOACTIVE GAS FRACTION OF TOTAL FP)			

TABLE C-XLIII

TMI-2 IF OPERATED 25K HRS AT 2772. MW CONT. CINDER-10(LASL)8/79

CONTENT OF NOBLE GASES AND HALOGENS
 (EXCEEDING 1.00000E-02 PERCENT OF TOTAL GAS)

TIME STEP 35
 ELAPSED TIME=9.36714E+07 SEC
 COOLING TIME=1.90000E+05 SEC
 TOTAL ACTIVITY=7.24149E+19
 CURIES IN ALL FP= 1.95716E+09
 IN ALL GAS= 2.64419E+08
 IN HALOGENS= 1.39904E+08
 IN NOBLE GAS= 1.24616E+08
 TOTAL BETA MEV/FISS=3.21794E-01
 TOTAL GAMMA MEV/FISS=4.53272E-01
 TOTAL BETA+GAMMA=7.75073E-01
 FRACTION OF TOTALS IN GAS PRODUCTS
 BETA FRACTION=1.09507E-01
 GAMMA FRACTION=2.17119E-01
 TOTAL FRACTION=1.72441E-01

FRACTIONAL DENSITY ALL GAS=1.55499E-01
 DENSITY OF RADIOACTIVE GAS=6.12303E-03

FRACTIONAL GAS ACTIVITY=1.35104E-01

DECAY POWER IN MW FOR ALL FP IS
 TOTAL BETA MW=3.55107E+10
 TOTAL GAMMA MW=5.00204E+00
 TOTAL BETA+GAMMA MW=9.55312E+00
 (MULTIPLY MEV/F BY 1.10352E+01 TO GET MW)

TABULAR VALUES ARE GIVEN AS FRACTIONS OF ALL NUCLIDES

NUCLIDE	DENSITY	CURIES	BETA MEV/F	GAMMA MEV/F	B+G MEV/F
Z A S					
35BR 82 0	4.85870E-09	5.25465E-05	2.40429E-05	3.23086E-04	1.98929E-04
36KR 85 0	9.35428E-04	3.87998E-04	3.11925E-04	1.96999E-06	1.30615E-04
53 I130 0	2.31389E-09	7.14456E-05	6.89762E-05	3.51395E-04	2.34099E-04
53 I131 0	1.40404E-04	2.79446E-02	1.68949E-02	2.51581E-02	2.17240E-02
53 I132 0	1.82476E-06	3.05951E-02	5.24270E-02	1.58736E-01	1.14599E-01
53 I133 0	6.81369E-06	1.25462E-02	1.70996E-02	1.74272E-02	1.72912E-02
54XE133 0	1.91765E-04	5.78471E-02	1.92540E-02	1.09265E-02	1.43839E-02
54XE133 1	3.08273E-04	2.20603E-03	0.	1.19056E-03	6.96265E-04
53 I135 0	5.36500E-09	3.12033E-04	4.01292E-04	1.05372E-03	7.82845E-04
54XE135 0	7.16943E-07	2.99441E-03	3.03158E-03	1.81564E-03	2.32047E-03
TOTAL GAS	2.23989E+03	2.64419E+09	3.52389E-02	9.84153E-02	1.33654E-01
	8.81989E+01				(RADIOACTIVE GAS DENSITY)
TOTAL FP	1.44045E+04	1.95715E+09	3.21794E-01	4.53279E-01	7.75073E-01
TOTAL GAS FRACTIONS	1.55499E-01	1.35104E-01	1.09507E-01	2.17119E-01	1.72441E-01
	6.12303E-03				(RADIOACTIVE FRACTION OF TOTAL FP)
NOBLE GAS FRACTIONS	1.48330E-01	5.36716E-02	2.25998E-02	1.40695E-02	1.76111E-02
	1.13244E-03				(NOBLE RADIOACTIVE GAS FRACTION OF TOTAL FP)

TABLE C-VLIV

TMI-2 IF OPERATED 26K HPS AT 2772. MW CONT. CINDER-10(LASL)8/79

CONTENT OF NOBLE GASES AND HALOGENS
 (EXCEEDING 1.00000E-02 PERCENT OF TOTAL GAS)

TIME STEP 36
 ELAPSED TIME=9.38514E+07 SEC
 COOLING TIME=3.60000E+05 SEC
 TOTAL ACTIVITY=6.02494E+19
 CURIES IN ALL FP= 1.43106E+09
 IN ALL GAS= 1.82335E+09
 IN HALOGENS= 9.99449E+07
 IN NOBLE GAS= 9.33900E+07
 TOTAL BETA MEV/FISS=2.69063E-01

TOTAL GAMMA MEV/FISS=3.71922E-01
 TOTAL BETA+GAMMA=6.41995E-01

FRACTION OF TOTALS IN GAS PRODUCTS
 BETA FRACTION=7.95141E-02
 GAMMA FRACTION=1.65570E-01
 TOTAL FRACTION=1.29377E-01
 FRACTIONAL DENSITY ALL GAS=1.55478E-01
 DENSITY OF RADIOACTIVE GAS=6.05458E-03
 FRACTIONAL GAS ACTIVITY=1.11789E-01

DECAY POWER IN MW FOR ALL FP IS
 TOTAL BETA MW=2.97911E+00
 TOTAL GAMMA MW=4.10425E+00
 TOTAL BETA+GAMMA MW=7.08336E+00
 (MULTIPLY MEV/F BY 1.10352E+01 TO GET MW)

TABULAR VALUES ARE GIVEN AS FRACTIONS OF ALL NUCLIDES

NUCLIDE	DENSITY	CURIES	BETA MEV/F	GAMMA MEV/F	B+G MEV/F
Z A S					
36KR 85 0	9.35094E-04	4.56870E-04	3.71556E-04	2.40004E-06	1.57659E-04
53 I131 0	1.18092E-04	2.81222E-02	1.59302E-02	2.57889E-02	2.20631E-02
53 I132 0	1.17013E-06	2.35340E-02	4.00736E-02	1.24056E-01	8.87349E-02
53 I133 0	1.28752E-04	2.84470E-03	3.85148E-03	4.01339E-03	3.94530E-03
54XE133 0	1.51816E-04	5.49519E-02	1.81694E-02	1.05424E-02	1.37502E-02
54XE133 1	1.77525E-06	1.52437E-03	0.	8.35583E-04	4.84155E-04
TOTAL GAS	2.23958E+03 8.72129E+01 (RADIOACTIVE GAS DENSITY)	1.82335E+08	2.14659E-02	6.15790E-02	8.30448E-02
TOTAL FP	1.44045E+04	1.63106E+09	2.69963E-01	3.71922E-01	6.41995E-01
TOTAL GAS FRACTIONS	1.55478E-01 6.05458E-03 (RADIOACTIVE FRACTION OF TOTAL FP)	1.11789E-01	7.95141E-02	1.65570E-01	1.29377E-01
NOBLE GAS FRACTIONS	1.48334E-01 1.09010E-03 (NOBLE RADIOACTIVE GAS FRACTION OF TOTAL FP)	5.72571E-02	1.86405E-02	1.15304E-02	1.45207E-02

TABLE C-XLV

TMI-2 IF OPERATED 26K WRS AT 2772. MW CONT. CINDER-10(LASL)8/79

CONTENT OF NOBLE GASES AND HALOGENS
 (EXCEEDING 1.0000E-02 PERCENT OF TOTAL GAS)

TIME STEP 37
 ELAPSED TIME=9.42114E+07 SEC
 COOLING TIME=7.20077E+05 SEC
 TOTAL ACTIVITY=4.92032E+19
 CURIES IN ALL FP= 1.32382E+09
 IN ALL GAS= 1.02954E+09
 IN HALOGENS= 4.80920E+07

IN NOBLE GAS= 5.47617E+07
 TOTAL BETA MEV/FISS=2.27463E-01

TOTAL GAMMA MEV/FISS=2.91198E-01
 TOTAL BETA+GAMMA=5.18661E-01
 FRACTION OF TOTALS IN GAS PRODUCTS
 BETA FRACTION=4.69851E-02
 GAMMA FRACTION=9.68103E-02
 TOTAL FRACTION=7.49590E-02
 FRACTIONAL DENSITY ALL GAS=1.55444E-01
 DENSITY OF RADIOACTIVE GAS=5.95776E-03
 FRACTIONAL GAS ACTIVITY=7.73443E-02

DECAY POWER IN MW FOR ALL FP IS
 TOTAL BETA MW=2.51011E+00
 TOTAL GAMMA MW=3.21344E+00
 TOTAL BETA+GAMMA MW=5.72355E+00
 (MULTIPLY MEV/F BY 1.10352E+01 TO GET MW)

TABULAR VALUES ARE GIVEN AS FRACTIONS OF ALL NUCLIDES

NUCLIDE	DENSITY	CURIES	BETA MEV/F	GAMMA MEV/F	B+G MEV/F
Z A S					
36KR 85 0	9.34397E-04	5.59954E-04	4.40654E-04	3.06310E-06	1.94972E-04
53 I131 0	8.27369E-05	2.41441E-02	1.40777E-02	2.30767E-02	1.91301E-02
53 I132 0	4.81167E-07	1.18694E-02	1.95574E-02	6.51541E-02	4.51573E-02
53 I133 0	4.59719E-08	1.24542E-04	1.63215E-04	1.83027E-04	1.74338E-04
54XE133 0	8.97210E-05	3.98327E-02	1.27441E-02	7.95759E-03	1.00568E-02
54XE133 1	5.07995E-07	5.35009E-04	0.	3.05381E-04	1.71454E-04
TOTAL GAS	2.23908E+03	1.02854E+08	1.06874E-02	2.81910E-02	3.88783E-02
	8.58181E+01		(RADIOACTIVE GAS DENSITY)		
TOTAL FP	1.44044E+04	1.32982E+09	2.27463E-01	2.91198E-01	5.18661E-01
TOTAL GAS FRACTIONS	1.55444E-01	7.73443E-02	4.69851E-02	9.68103E-02	7.49590E-02
	5.95776E-03	(RADIOACTIVE FRACTION OF TOTAL FP)			
NOBLE GAS FRACTIONS	1.48329E-01	4.11799E-02	1.31949E-02	8.36973E-03	1.04814E-02
	1.02591E-03	(NOBLE RADIOACTIVE GAS FRACTION OF TOTAL FP)			

TABLE C-XLVI

TMI-2 IF OPERATED 26K HRS AT 2772. MW CONT. CINDER-10(LASL)8/79

CONTENT OF NOBLE GASES AND HALOGENS
 (EXCEEDING 1.00000E-02 PERCENT OF TOTAL GAS)

TIME STEP 38
 ELAPSED TIME=9.52914E+07 SEC
 COOLING TIME=1.90000E+06 SEC
 TOTAL ACTIVITY=3.59195E+19
 CURIES IN ALL FP= 2.70797E+08

IN ALL GAS= 2.34136E+07
 IN HALOGENS= 1.20440E+07

IN NOBLE GAS= 1.13696E+07
 TOTAL BETA MEV/FISS=1.75929E-01
 TOTAL GAMMA MEV/FISS=1.88930E-01
 TOTAL BETA+GAMMA=3.64858E-01
 FRACTION OF TOTALS IN GAS PRODUCTS
 BETA FRACTION=1.17599E-02
 GAMMA FRACTION=2.16229E-02
 TOTAL FRACTION=1.68671E-02
 FRACTIONAL DENSITY ALL GAS=1.55401E-01
 DENSITY OF RADIOACTIVE GAS=5.83940E-03
 FRACTIONAL GAS ACTIVITY=2.41179E-02

DECAY POWER IN MW FOR ALL FP IS
 TOTAL BETA MW=1.94141E+00
 TOTAL GAMMA MW=2.08499E+00
 TOTAL BETA+GAMMA MW=4.02629E+00
 (MULTIPLY MEV/F BY 1.10352E+01 TO GET MW)

TABULAR VALUES ARE GIVEN AS FRACTIONS OF ALL NUCLIDES

NUCLIDE	DENSITY	CURIES	BETA MEV/F	GAMMA MEV/F	B+G MEV/F
Z A S					
36KR 85 0	9.32338E-04	7.65341E-04	5.68479E-04	4.71074E-06	2.76549E-04
53 I131 0	2.81825E-05	1.12759E-02	6.19992E-03	1.21154E-02	9.26307E-03
53 I132 0	3.34563E-09	1.13052E-03	1.75920E-03	6.98247E-03	4.46342E-03
54XE133 0	1.76059E-05	1.07069E-02	3.23332E-03	2.40675E-03	2.80530E-03
TOTAL GAS	2.23845E+03	2.34136E+07	2.06890E-03	4.08521E-03	6.15410E-03
	8.41127E+01	(RADIOACTIVE GAS DENSITY)			
TOTAL FP	1.44044E+04	9.70797E+08	1.75929E-01	1.88930E-01	3.64858E-01
TOTAL GAS FRACTIONS	1.55401E-01	2.41179E-02	1.17599E-02	2.16229E-02	1.68671E-02
	5.83940E-03	(RADIOACTIVE FRACTION OF TOTAL FP)			
NOBLE GAS FRACTIONS	1.48325E-01	1.17116E-02	3.80179E-03	2.52486E-03	3.14057E-03
	9.50791E-04	(NOBLE RADIOACTIVE GAS FRACTION OF TOTAL FP)			

TABLE C-XLVII

TMI-2 IF OPERATED 26K HPS AT 2772. MW CONT. CINDER-10(LASL)8/79

CONTENT OF NOBLE GASES AND HALOGENS
 (EXCEEDING 1.00000E-02 PERCENT OF TOTAL GAS)

TIME STEP 39
 ELAPSED TIME=9.70916E+07 SEC
 COOLING TIME=3.60007E+06 SEC
 TOTAL ACTIVITY=2.62032E+19
 CURIES IN ALL FP= 7.27113E+09

IN ALL GAS= 3.33139E+06
 IN HALOGENS= 1.82983E+05

IN NOBLE GAS= 1.50156E+06
 TOTAL BETA MEV/FISS=1.40317E-01
 TOTAL GAMMA MEV/FISS=1.24610E-01
 TOTAL BETA+GAMMA=2.64919E-01
 FRACTION OF TOTALS IN GAS PRODUCTS
 BETA FRACTION=2.29114E-03
 GAMMA FRACTION=3.47842E-03
 TOTAL FRACTION=2.84960E-03
 FRACTIONAL DENSITY ALL GAS=1.55401E-01
 DENSITY OF RADIOACTIVE GAS=5.80947E-03
 FRACTIONAL GAS ACTIVITY=4.58166E-03

DECAY POWER IN MW FOR ALL FP IS
 TOTAL BETA MW=1.54935E+00
 TOTAL GAMMA MW=1.37510E+00
 TOTAL BETA+GAMMA MW=2.92345E+00
 (MULTIPLY MEV/F BY 1.10352E+01 TO GET MW)

TABULAR VALUES ARE GIVEN AS FRACTIONS OF ALL NUCLIDES

NUCLIDE	DENSITY	CURIES	BETA MEV/F	GAMMA MEV/F	B+G MEV/F
Z A S					
36KR 85 0	9.28917E-04	1.01909E-03	7.10166E-04	7.11603E-06	3.79474E-04
53 I131 0	4.67792E-05	2.49892E-03	1.29031E-03	3.04894E-03	2.11751E-03
54XE133 0	1.14975E-04	9.33542E-04	2.64751E-04	2.38300E-04	2.52309E-04
TOTAL GAS	2.23844E+03	3.33139E+06	3.21470E-04	4.33444E-04	7.54914E-04
	8.36809E+01		(RADIOACTIVE GAS DENSITY)		
TOTAL FP	1.44042E+04	7.27113E+08	1.49310E-01	1.24610E-01	2.64919E-01
TOTAL GAS FRACTIONS	1.55401E-01	4.58166E-03	2.29114E-03	3.47842E-03	2.84960E-03
	5.80947E-03	(RADIOACTIVE FRACTION OF TOTAL FP)			
NOBLE GAS FRACTIONS	1.48331E-01	2.06510E-03	9.74918E-04	3.05013E-04	6.59816E-04
	9.30395E-04	(NOBLE RADIOACTIVE GAS FRACTION OF TOTAL FP)			

TABLE C-XLVIII

TMI-2 IF OPERATED 26K HRS AT 2772. MW CONT. CINDER-10(LASL)8/79

CONTENT OF NOBLE GASES AND HALOGENS
 (EXCEEDING 1.00000E-02 PERCENT OF TOTAL GAS)

TIME STEP 40
 ELAPSED TIME=1.00492E+08 SEC
 COOLING TIME=7.20000E+06 SEC
 TOTAL ACTIVITY=1.87185E+19
 CURIES IN ALL FP= 5.05906E+09
 IN ALL GAS= 7.96522E+05

IN HALOGENS= 5.00604E+04
 IN NOBLE GAS= 7.45462E+05

TOTAL BETA MEV/FISS=1.00384E-01
 TOTAL GAMMA MEV/FISS=7.73990E-02
 TOTAL BETA+GAMMA=1.86783E-01
 FRACTION OF TOTALS IN GAS PRODUCTS
 BETA FRACTION=9.51309E-04
 GAMMA FRACTION=1.58441E-04
 TOTAL FRACTION=6.22761E-04
 FRACTIONAL DENSITY ALL GAS=1.55418E-01
 DENSITY OF RADIOACTIVE GAS=5.81172E-03
 FRACTIONAL GAS ACTIVITY=1.57445E-03

DECAY POWER IN MW FOR ALL FP IS
 TOTAL BETA MW=1.20709E+00
 TOTAL GAMMA MW=8.54116E-01
 TOTAL BETA+GAMMA MW=2.05120E+00
 (MULTIPLY MEV/F BY 1.10352E+01 TO GET MW)

TABULAR VALUES ARE GIVEN AS FRACTIONS OF ALL NUCLIDES

NUCLIDE	DENSITY	CURIES	BETA MEV/F	GAMMA MEV/F	B+G MEV/F
Z A S					
36KR 85 0	9.22112E-04	1.45249E-03	9.04259E-04	1.13724E-05	5.34266E-04
TOTAL GAS	2.23864E+03 8.37119E+01 (RADIOACTIVE GAS DENSITY)	7.96522E+05	1.04059E-04	1.22632E-05	1.16321E-04
TOTAL FP	1.44040E+04	5.05906E+08	1.09384E-01	7.73990E-02	1.86783E-01
TOTAL GAS FRACTIONS	1.55418E-01 5.81172E-03 (RADIOACTIVE FRACTION OF TOTAL FP)	1.57445E-03	9.51309E-04	1.58441E-04	6.22761E-04
NOBLE GAS FRACTIONS	1.48330E-01 9.22152E-04 (NOBLE RADIOACTIVE GAS FRACTION OF TOTAL FP)	1.47549E-03	9.04704E-04	2.31793E-05	5.40005E-04

TABLE C-XLIX

TMI-2 IF OPERATED 26K HRS AT 2772. MW CONT. CINDER-10(LASL)8/79

CONTENT OF NOBLE GASES AND HALOGENS
 (EXCEEDING 1.00000E-02 PERCENT OF TOTAL GAS)

TIME STEP 41
 ELAPSED TIME=1.11422E+08 SEC
 COOLING TIME=1.80000E+07 SEC
 TOTAL ACTIVITY=9.94017E+18
 CURIES IN ALL FP= 2.58453E+08
 IN ALL GAS= 7.18767E+05
 IN HALOGENS= 3.68343E+00
 IN NOBLE GAS= 7.18763E+05
 TOTAL BETA MEV/FISS=7.18403E-02

TOTAL GAMMA MEV/FYSS=3.31937E-02
 TOTAL BETA+GAMMA=1.05034E-01

FRACTION OF TOTALS IN GAS PRODUCTS
 BETA FRACTION=1.34673E-03
 GAMMA FRACTION=2.59644E-05
 TOTAL FRACTION=9.29328E-04
 FRACTIONAL DENSITY ALL GAS=1.55427E-01
 DENSITY OF RADIOACTIVE GAS=5.80172E-03
 FRACTIONAL GAS ACTIVITY=2.67544E-03

DECAY POWER IN MW FOR ALL FP IS
 TOTAL BETA MW=7.92775E-01
 TOTAL GAMMA MW=3.56307E-01
 TOTAL BETA+GAMMA MW=1.15909E+00
 (MULTIPLY MEV/F BY 1.10352E+01 TO GET MW)

TABULAR VALUES ARE GIVEN AS FRACTIONS OF ALL NUCLIDES

NUCLIDE	DENSITY	CURIES	BETA MEV/F	GAMMA MEV/F	B+G MEV/F
Z A S					
36KR 85 0	9.01991E-04	2.67540E-03	1.34672E-03	2.59377E-05	9.29318E-04
TOTAL GAS	2.23966E+03 8.35641E+01 (RADIOACTIVE GAS DENSITY)	7.19757E+05	9.67492E-05	8.61855E-07	9.76111E-05
TOTAL FP	1.44033E+04	2.68453E+08	7.19403E-02	3.31937E-02	1.05034E-01
TOTAL GAS FRACTIONS	1.55427E-01 5.80172E-03 (RADIOACTIVE FRACTION OF TOTAL FP)	2.67544E-03	1.34673E-03	2.59644E-05	9.29328E-04
NOBLE GAS FRACTIONS	1.48316E-01 9.01992E-04 (NOBLE RADIOACTIVE GAS FRACTION OF TOTAL FP)	2.67543E-03	1.34672E-03	2.59561E-05	9.29324E-04

TABLE C-1

TMI-2 IF OPERATED 26K HRS AT 2772. MW CONT. CINDER-10(LASL)8/79

CONTENT OF NOBLE GASES AND HALOGENS
 (EXCEEDING 1.00000E-02 PERCENT OF TOTAL GAS)

TIME STEP 42
 ELAPSED TIME=1.25029E+08 SEC
 COOLING TIME=3.15340E+07 SEC
 TOTAL ACTIVITY=6.47132E+19
 CURIES IN ALL FP= 1.74901E+09
 IN ALL GAS= 6.99117E+05
 IN HALOGENS= 2.63716E+00
 IN NOBLE GAS= 6.99114E+05
 TOTAL BETA MEV/FYSS=4.97684E-02
 TOTAL GAMMA MEV/FYSS=1.85063E-02
 TOTAL BETA+GAMMA=6.82747E-02
 FRACTION OF TOTALS IN GAS PRODUCTS

BETA FRACTION=1.99095E-03
GAMMA FRACTION=4.52534E-05

TOTAL FRACTION=1.39058E-03
FRACTIONAL DENSITY ALL GAS=1.55417E-01
DENSITY OF RADIOACTIVE GAS=5.77815E-03
FRACTIONAL GAS ACTIVITY=3.99722E-03

DECAY POWER IN MW FOR ALL FP IS
TOTAL BETA MW=5.49200E-01
TOTAL GAMMA MW=2.04227E-01
TOTAL BETA+GAMMA MW=7.53436E-01
(MULTIPLY MEV/F BY 1.10352E+01 TO GET MW)

TABULAR VALUES ARE GIVEN AS FRACTIONS OF ALL NUCLIDES

NUCLIDE	DENSITY	CURIES	BETA MEV/F	GAMMA MEV/F	B+G MEV/F
Z A S					
36KR 85 0	8.77387E-04	3.99721E-03	1.99095E-03	4.52504E-05	1.39058E-03
TOTAL GAS	2.23841E+03 8.32204E+01 (RADIOACTIVE GAS DENSITY)	5.99117E+05	9.41752E-05	8.37498E-07	9.49427E-05
TOTAL FP	1.44026E+04	1.74901E+09	4.97686E-02	1.85068E-02	6.82754E-02
TOTAL GAS FRACTIONS	1.55417E-01 5.77815E-03 (RADIOACTIVE FRACTION OF TOTAL FP)	3.99722E-03	1.99095E-03	4.52534E-05	1.39058E-03
NOBLE GAS FRACTIONS	1.48300E-01 8.77389E-04 (NOBLE RADIOACTIVE GAS FRACTION OF TOTAL FP)	3.99721E-03	1.99095E-03	4.52504E-05	1.39058E-03

TABLE C-LI

THI-2 IF OPERATED 26K WPS AT 2772. MW CONT. CINDER-10(LASL)8/79

CONTENT OF NOBLE GASES AND HALOGENS
(EXCLUDING 1.00000E-02 PERCENT OF TOTAL GAS)

TIME STEP 43
ELAPSED TIME=1.29492E+08 SEC
COOLING TIME=3.50000E+07 SEC
TOTAL ACTIVITY=5.93253E+18
CURIES IN ALL FP= 1.57536E+09
 IN ALL GAS= 6.92757E+05
 IN HALOGENS= 2.63717E+03
 IN NOBLE GAS= 6.92755E+05
TOTAL BETA MEV/FISS=4.47003E-02
TOTAL GAMMA MEV/FISS=1.65493E-02
TOTAL BETA+GAMMA=6.12496E-02
FRACTION OF TOTALS IN GAS PRODUCTS
 BETA FRACTION=2.09610E-03
 GAMMA FRACTION=5.01489E-05
 TOTAL FRACTION=1.53417E-03

FRACTIONAL DENSITY ALL GAS=1.55413E-01
DENSITY OF RADIOACTIVE GAS=5.77029E-03

FRACTIONAL GAS ACTIVITY=4.39466E-03

DECAY POWER IN MW FOR ALL FP IS
TOTAL BETA MW=4.93279E-01
TOTAL GAMMA MW=1.92515E-01
TOTAL BETA+GAMMA MW=6.75993E-01
(MULTIPLY MEV/F BY 1.10352E+01 TO GET MW)

TABULAR VALUES ARE GIVEN AS FRACTIONS OF ALL NUCLIDES

NUCLIDE	DENSITY	CURIES	BETA MEV/F	GAMMA MEV/F	B+G MEV/F
Z A S					
36KR 85 0	8.69421E-04	4.39465E-03	2.08610E-03	5.01454E-05	1.53602E-03
TOTAL GAS	2.23831E+03 8.31057E+01 (RADIOACTIVE GAS DENSITY)	6.92757E+05	3.32492E-05	8.29880E-07	9.40791E-05
TOTAL FP	1.44023E+04	1.57636E+09	4.47003E-02	1.65483E-02	6.12486E-02
TOTAL GAS FRACTIONS	1.55413E-01 5.77029E-03 (RADIOACTIVE FRACTION OF TOTAL FP)	4.39466E-03	2.08610E-03	5.01489E-05	1.53602E-03
NOBLE GAS FRACTIONS	1.48294E-01 8.69422E-04 (NOBLE RADIOACTIVE GAS FRACTION OF TOTAL FP)	4.39465E-03	2.08610E-03	5.01454E-05	1.53602E-03

TABLE C-LTI

TMI-2 IF OPERATED 26K HRS AT 2772. MW CONT. CINDER-10(LASL)8/79

CONTENT OF NOBLE GASES AND HALOGENS
(EXCEEDING 1.0000E-02 PERCENT OF TOTAL GAS)

TIME STEP 44
ELAPSED TIME=1.65422E+09 SEC
COOLING TIME=7.20000E+07 SEC
TOTAL ACTIVITY=3.12391E+19
CURIES IN ALL FP= 9.44272E+07
 IN ALL GAS= 6.43543E+05
 IN HALOGENS= 2.43719E+00
 IN NOBLE GAS= 4.43540E+05
TOTAL BETA MEV/FISS=2.07246E-02
TOTAL GAMMA MEV/FISS=1.03742E-02
TOTAL BETA+GAMMA=3.11088E-02
FRACTION OF TOTALS IN GAS PRODUCTS
 BETA FRACTION=4.17972E-03
 GAMMA FRACTION=7.42979E-05
 TOTAL FRACTION=2.91007E-03
 FRACTIONAL DENSITY ALL GAS=1.55373E-01
 DENSITY OF RADIOACTIVE GAS=5.70925E-03
 FRACTIONAL GAS ACTIVITY=7.62245E-03

DECAY POWER IN MW FOR ALL FPTS
 TOTAL BETA MW=2.29701E-01
 TOTAL GAMMA MW=1.14504E-01
 TOTAL BETA+GAMMA MW=3.43205E-01
 (MULTIPLY MEV/F BY 1.10352E+01 TO GET MW)

TABULAR VALUES ARE GIVEN AS FRACTIONS OF ALL NUCLIDES

NUCLIDE	DENSITY	CURIES	BETA MEV/F	GAMMA MEV/F	B+G MEV/F
Z A S					
36KR 85 0	8.07756E-04	7.62242E-03	4.17978E-03	7.42924E-05	2.81007E-03
TOTAL GAS	2.23746E+03	5.43543E+05	9.65246E-05	7.70928E-07	8.73955E-05
	8.22163E+01	(RADIOACTIVE GAS DENSITY)			
TOTAL FP	1.44006E+04	8.44272E+07	2.07246E-02	1.03762E-02	3.11008E-02
TOTAL GAS FRACTIONS	1.55373E-01	7.62245E-03	4.17979E-03	7.42979E-05	2.81007E-03
	5.70925E-03	(RADIOACTIVE FRACTION OF TOTAL FP)			
NOBLE GAS FRACTIONS	1.49251E-01	7.62242E-03	4.17978E-03	7.42924E-05	2.81007E-03
	8.07757E-04	(NOBLE RADIOACTIVE GAS FRACTION OF TOTAL FP)			

TABLE C-LIII

TMI-2 IF OPERATED 26K HRS AT 2772. MW CONT. CINDER-10(LASL)8/79

CONTENT OF NOBLE GASES AND HALOGENS
 (EXCEEDING 1.00000E-02 PERCENT OF TOTAL GAS)

TIME STEP 45
 ELAPSED TIME=2.73492E+09 SEC
 COOLING TIME=1.80000E+09 SEC
 TOTAL ACTIVITY=1.22457E+19
 CURIES IN ALL FP= 3.42293E+07
 IN ALL GAS= 5.15900E+05
 IN HALOGENS= 2.63718E+09
 IN NOBLE GAS= 5.15899E+05
 TOTAL BETA MEV/FISS=5.52277E-03
 TOTAL GAMMA MEV/FISS=4.92045E-03
 TOTAL BETA+GAMMA=1.04432E-02
 FRACTION OF TOTALS IN GAS PRODUCTS
 BETA FRACTION=1.25740E-02
 GAMMA FRACTION=1.25604E-04
 TOTAL FRACTION=6.72876E-03
 FRACTIONAL DENSITY ALL GAS=1.55259E-01
 DENSITY OF RADIOACTIVE GAS=5.55067E-03
 FRACTIONAL GAS ACTIVITY=1.47449E-02

DECAY POWER IN MW FOR ALL FPTS

TOTAL BETA MW=6.09451E-02
 TOTAL GAMMA MW=5.42993E-02

TOTAL BETA+GAMMA MW=1.15243E-01
 (MULTIPLY MEV/F BY 1.10352E+01 TO GET MW)

TABULAR VALUES ARE GIVEN AS FRACTIONS OF ALL NUCLIDES

NUCLIDE	DENSITY	CURIES	BETA MEV/F	GAMMA MEV/F	B+G MEV/F
Z A S					
36KR 85 0	6.47733E-04	1.47449E-02	1.25739E-02	1.25593E-04	6.70875E-03
TOTAL GAS	2.23515E+03 7.99091E+01 (RADIOACTIVE GAS DENSITY)	5.15900E+05	6.94431E-05	6.18030E-07	7.00611E-05
TOTAL FP	1.43963E+04	3.49883E+07	5.52277E-03	4.92045E-03	1.04432E-02
TOTAL GAS FRACTIONS	1.55259E-01 5.55067E-03 (RADIOACTIVE FRACTION OF TOTAL FP)	1.47449E-02	1.25740E-02	1.25604E-04	6.70876E-03
NOBLE GAS FRACTIONS	1.48134E-01 6.47734E-04 (NOBLE RADIOACTIVE GAS FRACTION OF TOTAL FP)	1.47449E-02	1.25739E-02	1.25593E-04	6.70875E-03

TABLE C-LTV

TMI-2 IF OPERATED 26K HRS AT 2772. MW CONT. CINDER-10(LASL)8/79

SUMMARY OF PROBLEM OUTPUT

POWER, TOTAL CONTENT, FISS DENSITY, ACTIVITY

TS ELAPSED TIME (S)	BARNS/FISSION (LAST 4 GROUPS)				
1	4.2496E+06	4.9705E-02	2.3281E-01	1.7732E+01	6.6422E+02
2	8.4992E+06	5.1002E-02	2.4033E-01	1.8758E+01	3.7098E+02
3	1.2749E+07	5.1482E-02	2.4465E-01	1.9243E+01	2.7004E+02
4	1.6998E+07	5.2175E-02	2.4770E-01	1.9496E+01	2.1754E+02
5	2.1248E+07	5.2581E-02	2.5004E-01	1.9618E+01	1.8483E+02
6	2.5498E+07	5.2935E-02	2.5189E-01	1.9657E+01	1.6226E+02
7	2.9747E+07	5.3255E-02	2.5360E-01	1.9639E+01	1.4559E+02
8	3.3997E+07	5.3549E-02	2.5464E-01	1.9579E+01	1.3271E+02
9	3.8247E+07	5.3821E-02	2.5566E-01	1.9490E+01	1.2240E+02
10	4.2496E+07	5.4076E-02	2.5651E-01	1.9376E+01	1.1394E+02
11	4.6746E+07	5.4316E-02	2.5721E-01	1.9245E+01	1.0684E+02
12	5.0995E+07	5.4541E-02	2.5778E-01	1.9099E+01	1.0080E+02
13	5.5245E+07	5.4754E-02	2.5824E-01	1.8941E+01	9.5581E+01
14	5.9495E+07	5.4955E-02	2.5859E-01	1.8773E+01	9.1019E+01
15	6.3744E+07	5.5145E-02	2.5885E-01	1.8597E+01	8.6993E+01
16	6.7994E+07	5.5326E-02	2.5903E-01	1.8415E+01	8.3408E+01
17	7.2244E+07	5.5496E-02	2.5913E-01	1.8228E+01	8.0191E+01
18	7.6493E+07	5.5657E-02	2.5916E-01	1.8036E+01	7.7283E+01
19	8.0743E+07	5.5809E-02	2.5913E-01	1.7841E+01	7.4638E+01
20	8.4992E+07	5.5953E-02	2.5904E-01	1.7644E+01	7.2218E+01
21	8.9242E+07	5.6089E-02	2.5890E-01	1.7444E+01	6.9992E+01
22	9.3492E+07	5.6217E-02	2.5870E-01	1.7244E+01	6.7935E+01
23	9.3492E+07	5.6217E-02	2.5870E-01	1.7244E+01	6.7937E+01
24	9.3492E+07	5.6217E-02	2.5870E-01	1.7244E+01	6.7942E+01
25	9.3492E+07	5.6217E-02	2.5870E-01	1.7244E+01	6.7951E+01
26	9.3492E+07	5.6217E-02	2.5870E-01	1.7244E+01	6.7999E+01
27	9.3492E+07	5.6217E-02	2.5870E-01	1.7244E+01	6.8095E+01
28	9.3492E+07	5.6217E-02	2.5871E-01	1.7244E+01	6.8563E+01
29	9.3493E+07	5.6218E-02	2.5871E-01	1.7244E+01	6.9460E+01
30	9.3495E+07	5.6219E-02	2.5871E-01	1.7245E+01	7.2894E+01
31	9.3499E+07	5.6219E-02	2.5872E-01	1.7245E+01	7.6765E+01
32	9.3510E+07	5.6221E-02	2.5873E-01	1.7245E+01	8.3893E+01
33	9.3528E+07	5.6223E-02	2.5874E-01	1.7243E+01	8.6257E+01
34	9.3564E+07	5.6227E-02	2.5877E-01	1.7236E+01	7.7690E+01
35	9.3672E+07	5.6234E-02	2.5883E-01	1.7216E+01	5.7538E+01
36	9.3852E+07	5.6245E-02	2.5890E-01	1.7201E+01	5.4408E+01
37	9.4212E+07	5.6266E-02	2.5900E-01	1.7193E+01	5.5061E+01
38	9.5292E+07	5.6314E-02	2.5920E-01	1.7210E+01	5.5116E+01
39	9.7092E+07	5.6367E-02	2.5940E-01	1.7247E+01	5.4794E+01
40	1.0069E+08	5.6439E-02	2.5959E-01	1.7292E+01	5.4368E+01
41	1.1149E+08	5.6594E-02	2.5967E-01	1.7257E+01	5.3863E+01
42	1.2503E+08	5.6734E-02	2.5949E-01	1.7162E+01	5.3601E+01
43	1.2949E+08	5.6769E-02	2.5941E-01	1.7129E+01	5.3529E+01
44	1.6549E+08	5.6925E-02	2.5870E-01	1.6896E+01	5.3037E+01
45	2.7349E+08	5.6973E-02	2.5697E-01	1.6468E+01	5.2119E+01

TABLE C-LV

TMI-2 IF OPERATED 26K HRS AT 2772. MW CONT. CINDER-10(LASL)8/79

SUMMARY OF PROBLEM OUTPUT
POWER, TOTAL CONTENT, FISS DENSITY, ACTIVITY

TS	ELAPSED TIME (S)	COOLING TIME (S)	TOTAL NUC	FISS DENS	ACTIVITY	POWER
1	4.24962E+06	0.	7.25675E+02	3.62845E+02	4.74255E+20	2.77200E+09
2	8.49924E+06	0.	1.44979E+03	7.24666E+02	4.80327E+20	2.77200E+09
3	1.27489E+07	0.	2.16761E+03	1.09461E+03	4.81105E+20	2.77200E+09
4	1.69985E+07	0.	2.88191E+03	1.44259E+03	4.80203E+20	2.77200E+09
5	2.12481E+07	0.	3.59113E+03	1.79936E+03	4.78181E+20	2.77200E+09
6	2.54977E+07	0.	4.29453E+03	2.15155E+03	4.75314E+20	2.77200E+09
7	2.97473E+07	0.	4.97134E+03	2.50182E+03	4.71770E+20	2.77200E+09
8	3.39970E+07	0.	5.69081E+03	2.84879E+03	4.67672E+20	2.77200E+09
9	3.82466E+07	0.	6.36227E+03	3.19215E+03	4.63122E+20	2.77200E+09
10	4.24962E+07	0.	7.03519E+03	3.53165E+03	4.58214E+20	2.77200E+09
11	4.67458E+07	0.	7.69213E+03	3.86707E+03	4.53039E+20	2.77200E+09
12	5.09954E+07	0.	8.35390E+03	4.19927E+03	4.47684E+20	2.77200E+09
13	5.52451E+07	0.	8.99203E+03	4.52519E+03	4.42234E+20	2.77200E+09
14	5.94947E+07	0.	9.63477E+03	4.84780E+03	4.36766E+20	2.77200E+09
15	6.37443E+07	0.	1.02811E+04	5.16615E+03	4.31351E+20	2.77200E+09
16	6.79939E+07	0.	1.09782E+04	5.48032E+03	4.26050E+20	2.77200E+09
17	7.22435E+07	0.	1.16963E+04	5.79045E+03	4.20916E+20	2.77200E+09
18	7.64932E+07	0.	1.24357E+04	6.09669E+03	4.15991E+20	2.77200E+09
19	8.07428E+07	0.	1.31968E+04	6.39924E+03	4.11309E+20	2.77200E+09
20	8.49924E+07	0.	1.39700E+04	6.69829E+03	4.06895E+20	2.77200E+09
21	8.92420E+07	0.	1.47357E+04	6.99406E+03	4.02764E+20	2.77200E+09
22	9.34916E+07	0.	1.54945E+04	7.28678E+03	3.98926E+20	2.77200E+09
23	9.34916E+07	1.00000E+00	1.44045E+04	7.28678E+03	3.83448E+20	0.
24	9.34916E+07	4.00000E+00	1.44045E+04	7.28678E+03	3.61232E+20	0.
25	9.34917E+07	1.00000E+01	1.44045E+04	7.28678E+03	3.38753E+20	0.
26	9.34917E+07	4.00000E+01	1.44045E+04	7.28678E+03	2.95022E+20	0.
27	9.34917E+07	1.00000E+02	1.44045E+04	7.28678E+03	2.63663E+20	0.
28	9.34920E+07	4.00000E+02	1.44045E+04	7.28678E+03	2.19484E+20	0.
29	9.34926E+07	1.00000E+03	1.44045E+04	7.28678E+03	1.91487E+20	0.
30	9.34952E+07	3.60000E+03	1.44045E+04	7.28678E+03	1.52310E+20	0.
31	9.34988E+07	7.20000E+03	1.44045E+04	7.28678E+03	1.36000E+20	0.
32	9.35096E+07	1.80000E+04	1.44045E+04	7.28678E+03	1.17988E+20	0.
33	9.35276E+07	3.60000E+04	1.44045E+04	7.28678E+03	1.04429E+20	0.
34	9.35636E+07	7.20000E+04	1.44045E+04	7.28678E+03	9.03368E+19	0.
35	9.36716E+07	1.80000E+05	1.44045E+04	7.28678E+03	7.24149E+19	0.
36	9.38516E+07	3.60000E+05	1.44045E+04	7.28678E+03	6.03494E+19	0.
37	9.42116E+07	7.20000E+05	1.44045E+04	7.28678E+03	4.92032E+19	0.
38	9.52916E+07	1.80000E+06	1.44045E+04	7.28678E+03	3.59195E+19	0.
39	9.70916E+07	3.60000E+06	1.44045E+04	7.28678E+03	2.69032E+19	0.
40	1.00692E+08	7.20000E+06	1.44045E+04	7.28678E+03	1.87185E+19	0.
41	1.11492E+08	1.80000E+07	1.44033E+04	7.28678E+03	9.94017E+18	0.
42	1.25028E+08	3.15360E+07	1.44026E+04	7.28678E+03	6.47132E+18	0.
43	1.29492E+08	3.60000E+07	1.44023E+04	7.28678E+03	5.83253E+18	0.
44	1.65492E+08	7.20000E+07	1.44016E+04	7.28678E+03	3.12381E+18	0.
45	2.73492E+08	1.80000E+08	1.43963E+04	7.28678E+03	1.29457E+18	0.

TABLE C-LVI

TMI-2 IF OPERATED 26K WPS AT 2772. MW CONT. CINDER-10(LASL)8/79

SUMMARY OF PROBLEM OUTPUT
ENERGY DATA (MEV/F) ALL NUCLIDES

TS	COOLING TIME (S)	TOTAL DFNS	ACTIVITY	BETA MEV/F	GAMMA MEV/F	TOTAL MEV/F
1	0.	7.25675E+02	4.74255E+20	5.33997E+00	6.04754E+00	1.23875E+01
2	0.	1.44879E+03	4.80327E+20	5.29382E+00	6.00736E+00	1.23012E+01
3	0.	2.16761E+03	4.81105E+20	5.24641E+00	5.96067E+00	1.22071E+01
4	0.	2.88191E+03	4.80203E+20	5.20564E+00	5.91871E+00	1.21244E+01
5	0.	3.59113E+03	4.78181E+20	5.17077E+00	5.88107E+00	1.20518E+01
6	0.	4.29453E+03	4.75314E+20	5.14082E+00	5.84718E+00	1.19880E+01
7	0.	4.99134E+03	4.71770E+20	5.11490E+00	5.81660E+00	1.19315E+01
8	0.	5.68091E+03	4.67572E+20	5.09226E+00	5.78889E+00	1.18811E+01
9	0.	6.36277E+03	4.63122E+20	5.07227E+00	5.76365E+00	1.18359E+01
10	0.	7.03519E+03	4.58214E+20	5.05443E+00	5.74051E+00	1.17949E+01
11	0.	7.69913E+03	4.5339E+20	5.03931E+00	5.71914E+00	1.17574E+01
12	0.	8.35380E+03	4.47584E+20	5.02359E+00	5.69926E+00	1.17229E+01
13	0.	8.99903E+03	4.42234E+20	5.01000E+00	5.68065E+00	1.16906E+01
14	0.	9.63477E+03	4.36766E+20	5.99731E+00	5.66311E+00	1.16604E+01
15	0.	1.02611E+04	4.31351E+20	5.98536E+00	5.64649E+00	1.16319E+01
16	0.	1.08792E+04	4.26150E+20	5.97403E+00	5.63068E+00	1.16047E+01
17	0.	1.14863E+04	4.20916E+20	5.96320E+00	5.61558E+00	1.15788E+01
18	0.	1.20857E+04	4.15991E+20	5.95282E+00	5.60114E+00	1.15540E+01
19	0.	1.26748E+04	4.11309E+20	5.94283E+00	5.58732E+00	1.15301E+01
20	0.	1.32500E+04	4.06895E+20	5.93320E+00	5.57407E+00	1.15073E+01
21	0.	1.38357E+04	4.02764E+20	5.92391E+00	5.56140E+00	1.14853E+01
22	0.	1.44045E+04	3.98226E+20	5.91497E+00	5.54930E+00	1.14643E+01
23	1.00000E+00	1.44045E+04	3.93448E+20	5.43328E+00	5.18148E+00	1.06148E+01
24	4.00000E+00	1.44045E+04	3.81232E+20	4.82381E+00	4.73208E+00	9.55589E+00
25	1.00000E+01	1.44045E+04	3.39753E+20	4.26569E+00	4.32948E+00	8.59516E+00
26	4.00000E+01	1.44045E+04	2.95722E+20	3.30206E+00	3.57884E+00	6.88089E+00
27	1.00000E+02	1.44045E+04	2.43663E+20	2.67754E+00	3.03673E+00	5.71427E+00
28	4.00000E+02	1.44045E+04	2.19484E+20	1.91025E+00	2.34765E+00	4.25790E+00
29	1.00000E+03	1.44045E+04	1.91487E+20	1.50028E+00	1.96046E+00	3.46074E+00
30	3.60000E+03	1.44045E+04	1.52310E+20	1.00974E+00	1.36256E+00	2.37130E+00
31	7.20000E+03	1.44045E+04	1.36200E+20	9.27019E-01	1.07844E+00	1.90546E+00
32	1.80000E+04	1.44045E+04	1.17388E+20	6.46073E-01	8.12071E-01	1.45914E+00
33	3.60000E+04	1.44045E+04	1.74429E+20	5.25728E-01	6.81521E-01	1.20725E+00
34	7.20000E+04	1.44045E+04	9.03369E+19	4.21101E-01	5.74840E-01	9.95941E-01
35	1.80000E+05	1.44045E+04	7.26149E+19	3.21794E-01	4.53279E-01	7.75073E-01
36	3.60000E+05	1.44045E+04	5.03394E+19	2.52963E-01	3.71922E-01	6.41885E-01
37	7.20000E+05	1.44044E+04	4.92032E+19	2.27463E-01	2.91198E-01	5.18661E-01
38	1.80000E+06	1.44044E+04	3.52195E+19	1.75928E-01	1.88930E-01	3.54858E-01
39	3.60000E+06	1.44042E+04	2.69332E+19	1.40310E-01	1.24610E-01	2.64919E-01
40	7.20000E+06	1.44040E+04	1.97185E+19	1.09384E-01	7.73990E-02	1.86783E-01
41	1.80000E+07	1.44037E+04	9.94017E+18	7.18403E-02	3.31937E-02	1.05034E-01
42	3.15360E+07	1.44035E+04	5.47132E+18	4.97686E-02	1.85068E-02	6.82754E-02
43	3.60000E+07	1.44033E+04	5.93253E+18	4.47003E-02	1.65493E-02	6.12486E-02
44	7.20000E+07	1.44031E+04	3.12381E+18	2.07246E-02	1.03752E-02	3.11008E-02
45	1.80000E+08	1.43963E+04	1.29457E+18	5.52277E-03	4.92045E-03	1.04432E-02

TABLE C-LVII

TMI-2 IF OPERATED 25K MWS AT 2772. MW CONT. CINDER-10(LASL)8/79

SUMMARY OF PROBLEM OUTPUT

TOTAL GAS FRACTIONS

GAS FRACTIONS OF TOTAL NUCLIDE VALUES

TS	COOLING TIME (S)	DENSITY	R-DENSITY	ACTIVITY	BETA	GAMMA	TOTAL
1	0.	1.5957E-01	1.445E-02	1.932E-01	1.9729E-01	2.4428E-01	2.2023E-01
2	0.	1.5773E-01	9.712E-03	1.866E-01	1.9230E-01	2.3977E-01	2.1548E-01
3	0.	1.5717E-01	8.701E-03	1.821E-01	1.8834E-01	2.3646E-01	2.1184E-01
4	0.	1.5691E-01	7.497E-03	1.799E-01	1.8507E-01	2.3384E-01	2.0888E-01
5	0.	1.5676E-01	7.087E-03	1.763E-01	1.8227E-01	2.3166E-01	2.0637E-01
6	0.	1.5666E-01	6.835E-03	1.747E-01	1.7978E-01	2.2979E-01	2.0417E-01
7	0.	1.5657E-01	6.664E-03	1.721E-01	1.7753E-01	2.2813E-01	2.0220E-01
8	0.	1.5650E-01	6.547E-03	1.705E-01	1.7545E-01	2.2662E-01	2.0038E-01
9	0.	1.5643E-01	6.461E-03	1.691E-01	1.7350E-01	2.2521E-01	1.9868E-01
10	0.	1.5637E-01	6.399E-03	1.676E-01	1.7166E-01	2.2388E-01	1.9707E-01
11	0.	1.5630E-01	6.357E-03	1.662E-01	1.6988E-01	2.2261E-01	1.9553E-01
12	0.	1.5624E-01	6.314E-03	1.649E-01	1.6818E-01	2.2137E-01	1.9404E-01
13	0.	1.5617E-01	6.286E-03	1.634E-01	1.6651E-01	2.2017E-01	1.9259E-01
14	0.	1.5610E-01	6.265E-03	1.624E-01	1.6490E-01	2.1899E-01	1.9117E-01
15	0.	1.5603E-01	6.250E-03	1.612E-01	1.6331E-01	2.1783E-01	1.8978E-01
16	0.	1.5596E-01	6.238E-03	1.600E-01	1.6175E-01	2.1669E-01	1.8841E-01
17	0.	1.5589E-01	6.230E-03	1.588E-01	1.6023E-01	2.1556E-01	1.8706E-01
18	0.	1.5581E-01	6.224E-03	1.577E-01	1.5873E-01	2.1444E-01	1.8574E-01
19	0.	1.5574E-01	6.220E-03	1.566E-01	1.5726E-01	2.1334E-01	1.8443E-01
20	0.	1.5567E-01	6.218E-03	1.555E-01	1.5581E-01	2.1225E-01	1.8315E-01
21	0.	1.5560E-01	6.218E-03	1.545E-01	1.5440E-01	2.1118E-01	1.8190E-01
22	0.	1.5553E-01	6.218E-03	1.535E-01	1.5303E-01	2.1013E-01	1.8067E-01
23	1.0000E+00	1.5553E-01	6.218E-03	1.524E-01	1.5164E-01	2.0907E-01	1.7948E-01
24	4.0000E+00	1.5553E-01	6.218E-03	1.513E-01	1.5027E-01	2.0800E-01	1.7834E-01
25	1.0000E+01	1.5553E-01	6.218E-03	1.502E-01	1.4892E-01	2.0692E-01	1.7723E-01
26	4.0000E+01	1.5553E-01	6.218E-03	1.491E-01	1.4757E-01	2.0584E-01	1.7614E-01
27	1.0000E+02	1.5553E-01	6.218E-03	1.480E-01	1.4623E-01	2.0476E-01	1.7507E-01
28	4.0000E+02	1.5553E-01	6.218E-03	1.469E-01	1.4489E-01	2.0368E-01	1.7401E-01
29	1.0000E+03	1.5553E-01	6.218E-03	1.458E-01	1.4356E-01	2.0260E-01	1.7296E-01
30	3.6000E+03	1.5553E-01	6.218E-03	1.447E-01	1.4223E-01	2.0152E-01	1.7191E-01
31	7.2000E+03	1.5553E-01	6.218E-03	1.436E-01	1.4090E-01	2.0044E-01	1.7087E-01
32	1.8000E+04	1.5552E-01	6.216E-03	1.425E-01	1.3957E-01	1.9936E-01	1.6983E-01
33	3.6000E+04	1.5552E-01	6.195E-03	1.414E-01	1.3824E-01	1.9828E-01	1.6880E-01
34	7.2000E+04	1.5551E-01	6.175E-03	1.403E-01	1.3691E-01	1.9720E-01	1.6777E-01
35	1.8000E+05	1.5550E-01	6.123E-03	1.392E-01	1.3558E-01	1.9612E-01	1.6674E-01
36	3.6000E+05	1.5548E-01	6.055E-03	1.381E-01	1.3425E-01	1.9504E-01	1.6571E-01
37	7.2000E+05	1.5544E-01	5.958E-03	1.370E-01	1.3292E-01	1.9396E-01	1.6468E-01
38	1.8000E+06	1.5540E-01	5.839E-03	1.359E-01	1.3159E-01	1.9288E-01	1.6365E-01
39	3.6000E+06	1.5540E-01	5.809E-03	1.348E-01	1.3026E-01	1.9180E-01	1.6262E-01
40	7.2000E+06	1.5542E-01	5.812E-03	1.337E-01	1.2893E-01	1.9072E-01	1.6159E-01
41	1.8000E+07	1.5543E-01	5.822E-03	1.326E-01	1.2756E-01	1.8964E-01	1.6056E-01
42	3.1536E+07	1.5542E-01	5.778E-03	1.315E-01	1.2619E-01	1.8856E-01	1.5953E-01
43	3.6000E+07	1.5541E-01	5.770E-03	1.304E-01	1.2482E-01	1.8748E-01	1.5850E-01
44	7.2000E+07	1.5537E-01	5.709E-03	1.293E-01	1.2345E-01	1.8640E-01	1.5747E-01
45	1.8000E+08	1.5526E-01	5.551E-03	1.274E-01	1.2208E-01	1.8532E-01	1.5644E-01

TABLE C-LVIII

THI-2 IF OPERATED 26K HRS AT 2772. MW CONT. CINDER-10(LASL)8/79

SUMMARY OF PROBLEM OUTPUT

NOBLE GAS FRACTIONS

NOBLE GAS FRACTIONS OF TOTAL NUCLIDE VALUES

TS	COOLING TIME (S)	DENSITY	R-DENSITY	ACTIVITY	BETA	GAMMA	TOTAL
1	0.	1.5042E-01	6.855E-03	9.877E-02	9.6822E-02	9.2858E-02	9.4887E-02
2	0.	1.5042E-01	4.052E-03	9.474E-02	9.4276E-02	8.9993E-02	9.2180E-02
3	0.	1.5035E-01	3.092E-03	9.199E-02	9.2253E-02	8.7744E-02	9.0052E-02
4	0.	1.5026E-01	2.671E-03	8.991E-02	9.0581E-02	8.5912E-02	8.8302E-02
5	0.	1.5017E-01	2.298E-03	8.823E-02	8.9141E-02	8.4357E-02	8.6806E-02
6	0.	1.5007E-01	2.099E-03	8.680E-02	8.7863E-02	8.2994E-02	8.5483E-02
7	0.	1.4996E-01	1.934E-03	8.555E-02	8.6704E-02	8.1771E-02	8.4299E-02
8	0.	1.4986E-01	1.814E-03	8.441E-02	8.5632E-02	8.0648E-02	8.3204E-02
9	0.	1.4975E-01	1.714E-03	8.336E-02	8.4627E-02	7.9599E-02	8.2178E-02
10	0.	1.4964E-01	1.637E-03	8.237E-02	8.3672E-02	7.8606E-02	8.1206E-02
11	0.	1.4953E-01	1.569E-03	8.142E-02	8.2757E-02	7.7654E-02	8.0275E-02
12	0.	1.4942E-01	1.510E-03	8.052E-02	8.1873E-02	7.6733E-02	7.9374E-02
13	0.	1.4930E-01	1.453E-03	7.964E-02	8.1014E-02	7.5837E-02	7.8499E-02
14	0.	1.4919E-01	1.413E-03	7.879E-02	8.0176E-02	7.4960E-02	7.7643E-02
15	0.	1.4907E-01	1.371E-03	7.797E-02	7.9355E-02	7.4098E-02	7.6803E-02
16	0.	1.4896E-01	1.334E-03	7.716E-02	7.8549E-02	7.3249E-02	7.5977E-02
17	0.	1.4885E-01	1.300E-03	7.637E-02	7.7758E-02	7.2411E-02	7.5165E-02
18	0.	1.4873E-01	1.269E-03	7.560E-02	7.6980E-02	7.1586E-02	7.4365E-02
19	0.	1.4862E-01	1.240E-03	7.485E-02	7.6217E-02	7.0772E-02	7.3578E-02
20	0.	1.4851E-01	1.214E-03	7.411E-02	7.5469E-02	6.9971E-02	7.2806E-02
21	0.	1.4840E-01	1.189E-03	7.337E-02	7.4737E-02	6.9185E-02	7.2049E-02
22	0.	1.4830E-01	1.165E-03	7.270E-02	7.4023E-02	6.8414E-02	7.1308E-02
23	1.0000E+00	1.4830E-01	1.155E-03	7.298E-02	7.5448E-02	6.8526E-02	7.2069E-02
24	4.0000E+00	1.4830E-01	1.155E-03	7.293E-02	7.6268E-02	6.8209E-02	7.2277E-02
25	1.0000E+01	1.4830E-01	1.155E-03	7.317E-02	7.7323E-02	6.8201E-02	7.2729E-02
26	4.0000E+01	1.4830E-01	1.155E-03	7.296E-02	7.6312E-02	6.5819E-02	7.0855E-02
27	1.0000E+02	1.4830E-01	1.155E-03	7.013E-02	7.1783E-02	6.2979E-02	6.7104E-02
28	4.0000E+02	1.4830E-01	1.165E-03	6.494E-02	5.4051E-02	5.7636E-02	5.6028E-02
29	1.0000E+03	1.4830E-01	1.165E-03	6.051E-02	3.7697E-02	5.1160E-02	4.5324E-02
30	3.6000E+03	1.4830E-01	1.155E-03	6.124E-02	3.0395E-02	4.5702E-02	3.9191E-02
31	7.2000E+03	1.4830E-01	1.165E-03	6.387E-02	2.8930E-02	4.4952E-02	3.7941E-02
32	1.8000E+04	1.4831E-01	1.165E-03	6.704E-02	2.7971E-02	3.7335E-02	3.3186E-02
33	3.6000E+04	1.4831E-01	1.144E-03	6.941E-02	3.0150E-02	2.7847E-02	2.8850E-02
34	7.2000E+04	1.4832E-01	1.158E-03	6.966E-02	3.0602E-02	2.1087E-02	2.5110E-02
35	1.8000E+05	1.4833E-01	1.132E-03	6.367E-02	2.2600E-02	1.4070E-02	1.7611E-02
36	3.6000E+05	1.4833E-01	1.090E-03	5.726E-02	1.8640E-02	1.1530E-02	1.4521E-02
37	7.2000E+05	1.4833E-01	1.026E-03	4.119E-02	1.3185E-02	8.3697E-03	1.0481E-02
38	1.8000E+06	1.4832E-01	9.579E-04	1.171E-02	3.8018E-03	2.5249E-03	3.1406E-03
39	3.6000E+06	1.4833E-01	9.394E-04	2.065E-03	9.7492E-04	3.0501E-04	6.5982E-04
40	7.2000E+06	1.4833E-01	9.222E-04	1.475E-03	9.0570E-04	2.3179E-05	5.4000E-04
41	1.8000E+07	1.4832E-01	9.020E-04	2.675E-03	1.3467E-03	2.5956E-05	9.2932E-04
42	3.6000E+07	1.4830E-01	8.774E-04	3.997E-03	1.8909E-03	4.5250E-05	1.3906E-03
43	3.6000E+07	1.4829E-01	8.694E-04	4.395E-03	2.0861E-03	5.0145E-05	1.5360E-03
44	7.2000E+07	1.4825E-01	8.078E-04	7.622E-03	4.1798E-03	7.4292E-05	2.8101E-03
45	1.8000E+08	1.4813E-01	6.477E-04	1.474E-02	1.2574E-02	1.2559E-04	6.7088E-03

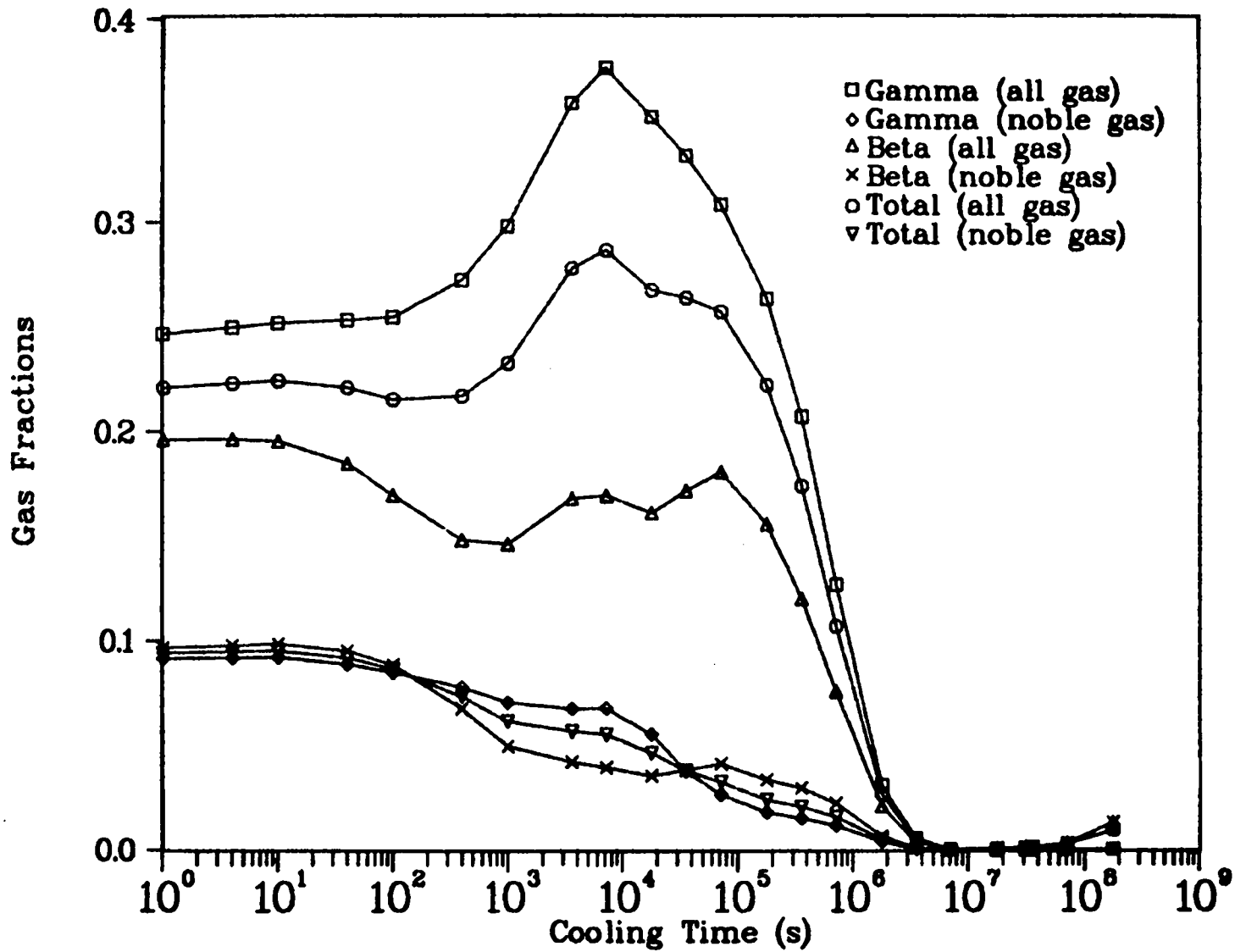

Fig. C-1.
TMI-2 gas fraction of total fission-product decay power.

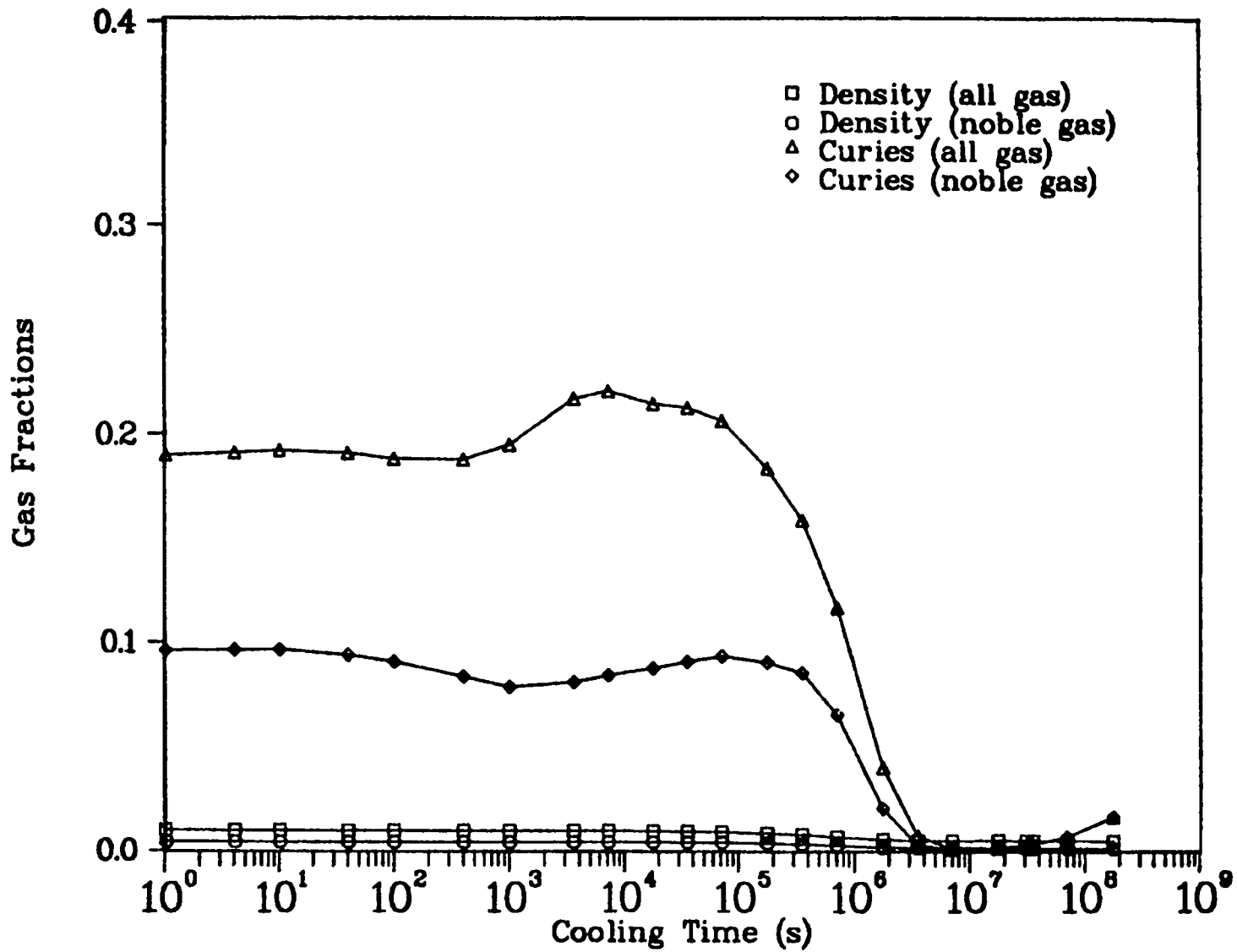

Fig. C-2.
TMI-2 gas fractions of total fission-product density and curies.

APPENDIX D

TMI-2 FUEL DECAY POWER SURVEY

In order to demonstrate the variation of decay power with irradiation and cooling times, a series of calculations have been performed to trace decay power of 2.96% enriched fuel over the cooling period $1 \text{ s} \leq t \leq 10^{13} \text{ s}$ following irradiation for periods in the range $1 \text{ s} \leq T \leq 3 \text{ years}$ at a power density of 33.8 kW/kg. The fuel specifications and power density are equivalent to those used in TMI-2 equilibrium core calculations described in Sec. VII B. of the text. The results of these calculations are given in Tables D-I through D-XI, which list actinide, fission-product and total decay power at 27 cooling times for each of the eleven irradiation cases. The total decay power values were summarized in Table VIII and Fig. 5 of the text. All decay power values are normalized to core power prior to shutdown. As in previous calculations, the EPRI-CINDER code was used to calculate actinide decay power values at all cooling times using exposure-dependent actinide cross sections and group flux ratios calculated with EPRI-CELL. The fission-product decay power values at cooling times $t \geq 10^5 \text{ s}$ were also calculated with this code.

Because of the absence of short-lived nuclides in the EPRI-CINDER fission-product library, decay power from fission products at short cooling times may be accurately calculated only with CINDER-10 or DKPOWR, which employs the pulse functions of ANS 5.1 STANDARD. The nuclide fission history of each EPRI-CINDER calculation was used in a companion DKPOWR calculation of fission-product decay power at cooling times $t \leq 4 \times 10^4 \text{ s}$. As previously described, the result of neutron absorption by fission-product nuclides during irradiation is a net increase in fission-product decay power. This increase is small at short cooling times for all realistic fuel irradiation histories; the effect is negligible if irradiation and cooling times are both brief. ANS 5.1 Standard offers an upper-bound absorption correction G_{max} , described in Appendix A, which may be used to account for the absorption effect in the absence of a specific, documented treatment. In the range of cooling times $1 \text{ s} \leq t \leq 4 \times 10^4 \text{ s}$, G_{max} monotonically increases fission-product decay power by 2% at $t = 1 \text{ s}$ to 9.8% at $t = 4 \times 10^4 \text{ s}$. Fission-product decay power values from DKPOWR tabulated here for irradiation times $T \leq 1 \text{ week}$ neglect the absorption effect; values tabulated for $T \geq 1 \text{ month}$

include the G_{\max} absorption correction for cooling times $t \leq 4 \times 10^4$ s. The absorption effect is, of course, included in all fission-product decay power values from EPRI-CINDER for cooling times $t \geq 10^5$ s.

Examination of the data of Tables D-I through D-XI, as well as the summary data of Table VIII and Fig. 5 of the text, lead to several observations.

Total decay power diminishes rapidly following brief irradiation periods due to the absence of a substantial inventory of long-lived fission-product and actinide nuclides produced in the fuel. Conversely, total decay power decreases more slowly with cooling time for longer irradiations because of the buildup of long-lived nuclides. The fractional contribution of actinide nuclides to the total decay power immediately following shutdown increases with irradiation time. For shorter irradiation times this may be viewed in terms of the rapid saturation of some short-lived fission products relative to ^{239}U and ^{239}Np , which strongly dominate actinide decay power during the first few days of cooling. Actinide decay power following very long irradiations contributes a greater fraction of the total decay power due to a number of factors. Fission-products are produced at a rate proportional to the fission rate; actinide nuclides are produced at a rate approximately proportional to the flux level, though diminished by actinide cross-section self-shielding as inventories increase. During these constant-power calculations the flux level increases due to depletion and reduced macroscopic fission cross section. The fission rate, however, slowly decreases due to the growing fission contributions of ^{239}Pu and ^{241}Pu , which yield slightly larger amounts of recoverable energy per fission (Q). *Q values for a variety of fissionable nuclides and incident neutron energies, including the appropriate LWR values used in EPRI-CINDER, are listed in Table D-XII.* Also, the fission products of ^{239}Pu following extended irradiation yield considerably lower decay power at small cooling times, as described in Appendix A.

Of the 11 irradiation cases calculated, the 1-month irradiation results in the highest total decay power at cooling times $t \lesssim 60$ s. It is interesting to note from the tabulated data that actinide decay power at any cooling time increases with irradiation time (or exposure). It is the fission-product contribution to decay power that is responsible for the elevated heating rate at these cooling times. The description of nuclide fission rates as functions of irradiation time T could be used with the functional

heating rates $F(t,T)$, defined by Eq. (2) and Appendix A, to determine the irradiation time T for which the fission-product decay power is a maximum. Such an exercise has not been conducted here.

Total decay power at very long cooling times is dominated by actinide nuclides in all cases. The general relationship between actinide and fission-product contributions to decay power is examined for several LWR systems in Appendix E.

TABLE D-I

TMI-2 FUEL DECAY POWER SURVEY

DECAY POWER FRACTION OF OPERATIONAL POWER FOLLOWING
SUSTAINED POWER AT 33.8 kW/kg FOR 1 SECOND

Cooling Time(s)	Fraction of Operational Power		
	Actinides	Fission Products	Total
1.00+0	6.365-07	3.176-03	3.177-03
4.00+0	6.356-07	1.569-03	1.570-03
1.00+1	6.337-07	7.195-04	7.201-04
4.00+1	6.245-07	1.750-04	1.756-04
1.00+2	6.065-07	6.415-05	6.476-05
4.00+2	5.242-07	1.176-05	1.228-05
1.00+3	3.918-07	4.711-06	5.103-06
4.00+3	9.412-08	9.716-07	1.066-06
1.00+4	1.036-08	2.887-07	2.991-07
4.00+4	5.357-09	4.563-08	5.099-08
1.00+5	4.714-09	1.188-08	1.660-08
4.00+5	2.898-09	1.928-09	4.826-09
1.00+6	2.009-09	7.831-10	2.792-09
4.00+6	1.876-09	1.545-10	2.030-09
1.00+7	1.876-09	4.807-11	1.924-09
4.00+7	1.876-09	5.149-12	1.881-09
1.00+8	1.876-09	1.166-12	1.877-09
4.00+8	1.876-09	3.238-13	1.876-09
1.00+9	1.875-09	2.025-13	1.876-09
4.00+9	1.875-09	2.076-14	1.875-09
1.00+10	1.874-09	2.347-16	1.874-09
4.00+10	1.870-09	1.973-18	1.870-09
1.00+11	1.862-09	1.943-18	1.862-09
4.00+11	1.820-09	1.840-18	1.820-09
1.00+12	1.740-09	1.652-18	1.740-09
4.00+12	1.399-09	1.009-18	1.399-09
1.00+13	9.400-10	4.918-19	9.400-10

TABLE D-II

TMI-2 FUEL DECAY POWER SURVEY

DECAY POWER FRACTION OF OPERATIONAL POWER FOLLOWING
SUSTAINED POWER AT 33.8 kW/kg FOR 10 SECONDS

Cooling Time(s)	<u>Fraction of Operational Power</u>		
	<u>Actinides</u>	<u>Fission Products</u>	<u>Total</u>
1.00+0	6.334-06	1.493-02	1.493-02
4.00+0	6.325-06	9.239-03	9.245-03
1.00+1	6.306-06	5.187-03	5.193-03
4.00+1	6.215-06	1.576-03	1.583-03
1.00+2	6.035-06	6.090-04	6.150-04
4.00+2	5.213-06	1.162-04	1.214-04
1.00+3	3.892-06	4.690-05	5.079-05
4.00+3	9.224-07	9.702-06	1.062-05
1.00+4	8.657-08	2.885-06	2.972-06
4.00+4	3.669-08	4.563-07	4.930-07
1.00+5	3.026-08	1.188-07	1.491-07
4.00+5	1.210-08	1.928-08	3.137-08
1.00+6	3.209-09	7.831-09	1.104-08
4.00+6	1.876-09	1.545-09	3.421-09
1.00+7	1.876-09	4.807-10	2.356-09
4.00+7	1.876-09	5.149-11	1.927-09
1.00+8	1.876-09	1.166-11	1.887-09
4.00+8	1.876-09	3.238-12	1.879-09
1.00+9	1.876-09	2.025-12	1.878-09
4.00+9	1.875-09	2.076-13	1.875-09
1.00+10	1.874-09	2.347-15	1.874-09
4.00+10	1.870-09	1.973-17	1.870-09
1.00+11	1.862-09	1.943-17	1.862-09
4.00+11	1.820-09	1.840-17	1.820-09
1.00+12	1.740-09	1.652-17	1.740-09
4.00+12	1.399-09	1.009-17	1.399-09
1.00+13	9.400-10	4.918-18	9.400-10

TABLE D-III

TMI-2 FUEL DECAY POWER SURVEY

DECAY POWER FRACTION OF OPERATIONAL POWER FOLLOWING
SUSTAINED POWER AT 33.8 kW/kg FOR 100 SECONDS

Cooling Time(s)	<u>Fraction of Operational Power</u>		
	<u>Actinides</u>	<u>Fission Products</u>	<u>Total</u>
1.00+0	6.195-05	3.074-02	3.080-02
4.00+0	6.186-05	2.342-02	2.348-02
1.00+1	6.168-05	1.708-02	1.714-02
4.00+1	6.078-05	8.386-03	8.447-03
1.00+2	5.903-05	4.130-03	4.189-03
4.00+2	5.099-05	1.044-03	1.095-03
1.00+3	3.807-05	4.493-04	4.873-04
4.00+3	9.015-06	9.560-05	1.046-04
1.00+4	8.388-07	2.868-05	2.952-05
4.00+4	3.500-07	4.556-06	4.906-06
1.00+5	2.857-07	1.188-06	1.473-06
4.00+5	1.041-07	1.927-07	2.968-07
1.00+6	1.520-08	7.831-08	9.351-08
4.00+6	1.881-09	1.545-08	1.733-08
1.00+7	1.877-09	4.806-09	6.683-09
4.00+7	1.877-09	5.149-10	2.392-09
1.00+8	1.877-09	1.166-10	1.994-09
4.00+8	1.877-09	3.238-11	1.909-09
1.00+9	1.877-09	2.025-11	1.897-09
4.00+9	1.876-09	2.076-12	1.878-09
1.00+10	1.876-09	2.347-14	1.876-09
4.00+10	1.871-09	1.973-16	1.871-09
1.00+11	1.863-09	1.943-16	1.863-09
4.00+11	1.821-09	1.840-16	1.821-09
1.00+12	1.741-09	1.652-16	1.741-09
4.00+12	1.399-09	1.009-16	1.399-09
1.00+13	9.401-10	4.918-17	9.401-10

TABLE D-IV

TMI-2 FUEL DECAY POWER SURVEY

DECAY POWER FRACTION OF OPERATIONAL POWER FOLLOWING
SUSTAINED POWER AT 33.8 kW/kg FOR 1000 SECONDS

<u>Cooling Time(s)</u>	<u>Fraction of Operational Power</u>		
	<u>Actinides</u>	<u>Fission Products</u>	<u>Total</u>
1.00+0	5.023-04	4.258-02	4.308-02
4.00+0	5.016-04	3.509-02	3.559-02
1.00+1	5.001-04	2.841-02	2.891-02
4.00+1	4.928-04	1.838-02	1.887-02
1.00+2	4.786-04	1.235-02	1.283-02
4.00+2	4.135-04	5.877-03	6.290-03
1.00+3	3.089-04	3.242-03	3.551-03
4.00+3	7.371-05	8.361-04	9.098-04
1.00+4	7.505-06	2.710-04	2.785-04
4.00+4	3.478-06	4.490-05	4.838-05
1.00+5	2.835-06	1.181-05	1.464-05
4.00+5	1.022-06	1.925-06	2.948-06
1.00+6	1.349-07	7.827-07	9.177-07
4.00+6	1.932-09	1.545-07	1.564-07
1.00+7	1.889-09	4.806-08	4.995-08
4.00+7	1.889-09	5.149-09	7.038-09
1.00+8	1.889-09	1.166-09	3.055-09
4.00+8	1.889-09	3.238-10	2.213-09
1.00+9	1.889-09	2.025-10	1.840-09
4.00+9	1.888-09	2.076-11	1.909-09
1.00+10	1.887-09	2.347-13	1.888-09
4.00+10	1.883-09	1.973-15	1.883-09
1.00+11	1.874-09	1.943-15	1.874-09
4.00+11	1.829-09	1.839-15	1.829-09
1.00+12	1.745-09	1.652-15	1.745-09
4.00+12	1.400-09	1.009-15	1.400-09
1.00+13	9.401-10	4.915-16	9.401-10

TABLE D-V

TMI-2 FUEL DECAY POWER SURVEY

DECAY POWER FRACTION OF OPERATIONAL POWER FOLLOWING
SUSTAINED POWER AT 33.8 kW/kg FOR 1 HOUR

<u>Cooling Time(s)</u>	<u>Fraction of Operational Power</u>		
	<u>Actinides</u>	<u>Fission Products</u>	<u>Total</u>
1.00+0	1.078-03	4.836-02	4.944-02
4.00+0	1.077-03	4.086-02	4.193-02
1.00+1	1.074-03	3.416-02	3.524-02
4.00+1	1.059-03	2.402-02	2.508-02
1.00+2	1.028-03	1.779-02	1.882-02
4.00+2	8.892-04	1.050-02	1.138-02
1.00+3	6.657-04	6.734-03	7.400-03
4.00+3	1.632-04	2.246-03	2.409-03
1.00+4	2.161-05	8.440-04	8.656-04
4.00+4	1.246-05	1.552-04	1.677-04
1.00+5	1.016-05	4.182-05	5.198-05
4.00+5	3.660-06	6.907-06	1.057-05
1.00+6	4.788-07	2.814-06	3.293-06
4.00+6	2.077-09	5.558-07	5.579-07
1.00+7	1.924-09	1.730-07	1.749-07
4.00+7	1.923-09	1.854-08	2.046-08
1.00+8	1.923-09	4.199-09	6.122-09
4.00+8	1.923-09	1.166-09	3.089-09
1.00+9	1.923-09	7.289-10	2.652-09
4.00+9	1.923-09	7.474-11	1.997-09
1.00+10	1.922-09	8.451-13	1.922-09
4.00+10	1.916-09	7.096-15	1.916-09
1.00+11	1.905-09	6.989-15	1.905-09
4.00+11	1.853-09	6.617-15	1.853-09
1.00+12	1.759-09	5.942-15	1.759-09
4.00+12	1.400-09	3.626-15	1.400-09
1.00+13	9.401-10	1.765-15	9.401-10

TABLE D-VI

TMI-2 FUEL DECAY POWER SURVEY

DECAY POWER FRACTION OF OPERATIONAL POWER FOLLOWING
SUSTAINED POWER AT 33.8 kW/kg FOR 1 DAY

<u>Cooling Time(s)</u>	<u>Fraction of Operational Power</u>		
	<u>Actinides</u>	<u>Fission Products</u>	<u>Total</u>
1.00+0	1.582-03	5.622-02	5.780-02
4.00+0	1.580-03	4.872-02	5.030-02
1.00+1	1.577-03	4.202-02	4.360-02
4.00+1	1.558-03	3.186-02	3.341-02
1.00+2	1.521-03	2.557-02	2.709-02
4.00+2	1.353-03	1.797-02	1.932-02
1.00+3	1.083-03	1.369-02	1.477-02
4.00+3	4.744-04	7.534-03	8.008-03
1.00+4	2.981-04	4.546-03	4.844-03
4.00+4	2.606-04	1.698-03	1.958-03
1.00+5	2.124-04	6.550-04	8.675-04
4.00+5	7.653-05	1.504-04	2.269-04
1.00+6	9.988-06	6.477-05	7.476-05
4.00+6	6.534-09	1.315-05	1.315-05
1.00+7	3.026-09	4.129-06	4.132-06
4.00+7	3.023-09	4.439-07	4.469-07
1.00+8	3.023-09	1.006-07	1.037-07
4.00+8	3.023-09	2.796-08	3.099-08
1.00+9	3.022-09	1.748-08	2.051-08
4.00+9	3.019-09	1.793-09	4.811-09
1.00+10	3.011-09	2.026-11	3.032-09
4.00+10	2.976-09	1.626-13	2.977-09
1.00+11	2.909-09	1.600-13	2.909-09
4.00+11	2.616-09	1.511-13	2.616-09
1.00+12	2.200-09	1.350-13	2.200-09
4.00+12	1.429-09	7.962-14	1.429-09
1.00+13	9.402-10	3.538-14	9.402-10

TABLE D-VII

TMI-2 FUEL DECAY POWER SURVEY

DECAY POWER FRACTION OF OPERATIONAL POWER FOLLOWING
SUSTAINED POWER AT 33.8 kW/kg FOR 1 WEEK

<u>Cooling Time(s)</u>	<u>Fraction of Operational Power</u>		
	<u>Actinides</u>	<u>Fission Products</u>	<u>Total</u>
1.00+0	2.265-03	5.804-02	6.031-02
4.00+0	2.264-03	5.055-02	5.282-02
1.00+1	2.260-03	4.386-02	4.612-02
4.00+1	2.241-03	3.370-02	3.594-02
1.00+2	2.205-03	2.742-02	2.962-02
4.00+2	2.040-03	1.982-02	2.186-02
1.00+3	1.773-03	1.553-02	1.730-02
4.00+3	1.169-03	9.330-03	1.050-02
1.00+4	9.816-04	6.266-03	7.248-03
4.00+4	8.778-04	2.721-03	3.599-03
1.00+5	7.157-04	1.718-03	2.434-03
4.00+5	2.581-04	7.156-04	9.737-04
1.00+6	3.385-05	3.653-04	3.992-04
4.00+6	2.826-08	8.472-05	8.475-05
1.00+7	9.861-09	2.804-05	2.805-05
4.00+7	9.848-09	3.076-06	3.085-06
1.00+8	9.848-09	7.020-07	7.119-07
4.00+8	9.849-09	1.956-07	2.054-07
1.00+9	9.847-09	1.223-07	1.321-07
4.00+9	9.823-09	1.254-08	2.236-08
1.00+10	9.773-09	1.414-10	9.915-09
4.00+10	9.544-09	1.104-12	9.545-09
1.00+11	9.116-09	1.086-12	9.117-09
4.00+11	7.312-09	1.023-12	7.313-09
1.00+12	4.905-09	9.101-13	4.906-09
4.00+12	1.603-09	5.215-13	1.603-09
1.00+13	9.411-10	2.123-13	9.413-10

TABLE D-VIII

TMI-2 FUEL DECAY POWER SURVEY

DECAY POWER FRACTION OF OPERATIONAL POWER FOLLOWING
SUSTAINED POWER AT 33.8 kW/kg FOR 1 MONTH

<u>Cooling Time(s)</u>	<u>Fraction of Operational Power</u>		
	<u>Actinides</u>	<u>Fission Products</u>	<u>Total</u>
1.00+0	2.421-03	6.016-02	6.258-02
4.00+0	2.419-03	5.261-02	5.503-02
1.00+1	2.415-03	4.587-02	4.829-02
4.00+1	2.397-03	3.553-02	3.793-02
1.00+2	2.360-03	2.916-02	3.152-02
4.00+2	2.194-03	2.151-02	2.370-02
1.00+3	1.926-03	1.718-02	1.911-02
4.00+3	1.317-03	1.093-02	1.225-02
1.00+4	1.126-03	7.364-03	8.490-03
4.00+4	1.008-03	4.621-03	5.630-03
1.00+5	8.224-04	2.742-03	3.564-03
4.00+5	2.973-04	1.531-03	1.828-03
1.00+6	3.955-05	9.379-04	9.774-04
4.00+6	7.861-08	2.824-05	2.825-04
1.00+7	3.674-08	1.080-04	1.080-04
4.00+7	3.677-08	1.276-05	1.280-05
1.00+8	3.690-08	2.990-06	3.027-06
4.00+8	3.738-08	8.348-07	8.722-07
1.00+9	3.783-08	5.215-07	5.593-07
4.00+9	3.773-08	5.346-08	9.120-08
1.00+10	3.704-08	6.001-10	3.764-08
4.00+10	3.510-08	4.856-12	3.510-08
1.00+11	3.284-08	4.781-12	3.285-08
4.00+11	2.472-08	4.503-12	2.473-08
1.00+12	1.471-08	4.000-12	1.472-08
4.00+12	2.228-09	2.275-12	2.230-09
1.00+13	9.445-10	9.045-13	9.454-10

TABLE D-IX

TMI-2 FUEL DECAY POWER SURVEY

DECAY POWER FRACTION OF OPERATIONAL POWER FOLLOWING
SUSTAINED POWER AT 33.8 kW/kg FOR 1 YEAR

Cooling Time(s)	<u>Fraction of Operational Power</u>		
	<u>Actinides</u>	<u>Fission Products</u>	<u>Total</u>
1.00+0	2.660-03	5.758-02	6.024-02
4.00+0	2.658-03	5.070-02	5.336-02
1.00+1	2.654-03	4.457-02	4.723-02
4.00+1	2.634-03	3.509-02	3.772-02
1.00+2	2.594-03	2.915-02	3.174-02
4.00+2	2.413-03	2.191-02	2.432-02
1.00+3	2.122-03	1.771-02	1.983-02
4.00+3	1.460-03	1.162-02	1.308-02
1.00+4	1.252-03	8.712-03	9.964-03
4.00+4	1.122-03	5.254-03	6.376-03
1.00+5	9.171-04	3.886-03	4.803-03
4.00+5	3.382-04	2.604-03	2.942-03
1.00+6	5.113-05	1.887-03	1.938-03
4.00+6	2.708-06	9.274-04	9.301-04
1.00+7	2.046-06	4.926-04	4.946-04
4.00+7	1.019-06	1.135-04	1.145-04
1.00+8	8.070-07	3.351-05	3.431-05
4.00+8	1.127-06	9.540-06	1.067-05
1.00+9	1.452-06	5.854-06	7.306-06
4.00+9	1.468-06	5.999-07	2.068-06
1.00+10	1.147-06	6.670-09	1.153-06
4.00+10	5.232-07	7.644-11	5.233-07
1.00+11	3.299-07	7.545-11	3.300-07
4.00+11	1.986-07	7.095-11	1.987-07
1.00+12	9.629-08	6.279-11	9.635-08
4.00+12	7.210-09	3.484-11	7.245-09
1.00+13	1.077-09	1.272-11	1.089-09

TABLE D-X

TMI-2 FUEL DECAY POWER SURVEY

DECAY POWER FRACTION OF OPERATIONAL POWER FOLLOWING
SUSTAINED POWER AT 33.8 kW/kg FOR 2 YEARS

<u>Cooling Time(s)</u>	<u>Fraction of Operational Power</u>		
	<u>Actinides</u>	<u>Fission Products</u>	<u>Total</u>
1.00+0	3.006-03	5.548-02	5.848-02
4.00+0	3.003-03	4.895-02	5.196-02
1.00+1	2.999-03	4.316-02	4.616-02
4.00+1	2.976-03	3.414-02	3.711-02
1.00+2	2.933-03	2.844-02	3.137-02
4.00+2	2.732-03	2.146-02	2.419-02
1.00+3	2.409-03	1.736-02	1.976-02
4.00+3	1.675-03	1.139-02	1.307-02
1.00+4	1.442-03	8.586-03	1.003-02
4.00+4	1.293-03	5.786-03	7.079-03
1.00+5	1.061-03	4.012-03	5.073-03
4.00+5	4.074-04	2.731-03	3.138-03
1.00+6	8.149-05	2.006-03	2.087-03
4.00+6	2.128-05	1.049-03	1.070-03
1.00+7	1.627-05	6.118-04	6.281-04
4.00+7	5.800-06	1.889-04	1.946-04
1.00+8	3.036-06	6.335-05	6.638-05
4.00+8	3.612-06	1.822-05	2.184-05
1.00+9	4.257-06	1.096-05	1.521-05
4.00+9	3.885-06	1.120-06	5.005-06
1.00+10	2.811-06	1.255-08	2.824-06
4.00+10	1.048-06	1.731-10	1.048-06
1.00+11	5.436-07	1.709-10	5.438-07
4.00+11	2.930-07	1.606-10	2.932-07
1.00+12	1.272-07	1.419-10	1.274-07
4.00+12	9.330-09	7.793-11	9.408-09
1.00+13	1.587-09	2.735-11	1.614-09

TABLE D-XI

TMI-2 FUEL DECAY POWER SURVEY

DECAY POWER FRACTION OF OPERATIONAL POWER FOLLOWING
SUSTAINED POWER AT 33.8 kW/kg FOR 3 YEARS

<u>Cooling Time(s)</u>	<u>Fraction of Operational Power</u>		
	<u>Actinides</u>	<u>Fission Products</u>	<u>Total</u>
1.00+0	3.384-03	5.370-02	5.708-02
4.00+0	3.382-03	4.744-02	5.082-02
1.00+1	3.377-03	4.189-02	4.527-02
4.00+1	3.352-03	3.323-02	3.658-02
1.00+2	3.304-03	2.773-02	3.103-02
4.00+2	3.082-03	2.096-02	2.404-02
1.00+3	2.726-03	1.696-02	1.968-02
4.00+3	1.916-03	1.113-02	1.305-02
1.00+4	1.658-03	8.413-03	1.007-02
4.00+4	1.487-03	5.726-03	7.213-03
1.00+5	1.225-03	4.093-03	5.318-03
4.00+5	4.948-04	2.817-03	3.311-03
1.00+6	1.301-04	2.088-03	2.218-03
4.00+6	5.713-05	1.133-03	1.190-03
1.00+7	4.425-05	6.989-04	7.431-04
4.00+7	1.627-05	2.514-04	2.677-04
1.00+8	8.482-06	9.156-05	1.000-04
4.00+8	8.223-06	2.623-05	3.445-05
1.00+9	8.039-06	1.550-05	2.354-05
4.00+9	6.058-06	1.583-06	7.641-06
1.00+10	4.071-06	1.788-08	4.089-06
4.00+10	1.404-06	2.800-10	1.404-06
1.00+11	6.794-07	2.764-10	6.797-07
4.00+11	3.436-07	2.597-10	3.438-07
1.00+12	1.378-07	2.293-10	1.381-07
4.00+12	1.067-08	1.251-10	1.079-08
1.00+13	2.427-09	4.286-11	2.470-09

TABLE D-XII

CALCULATION OF RECOVERABLE ENERGY PER FISSION, Q

Nuclide	Q'_{tot} ^a	-	E_V ^a	+	E_{inc} ^a	-	\bar{Q}	+	$v_T(E_{inc})^b$	+	E_c	-	Q
²³² Th	196.05 ± 0.20		10.94 ± 0.11										
Fast					3.35 ± 0.10		188.46 ± 0.25		2.420 ± 0.121		8.52 ± 0.85		196.98 ± 0.89
14 MeV					14.00 ± 0.20		199.11 ± 0.30		3.922 ± 0.196		17.64 ± 1.49		216.75 ± 1.52
²³³ Pa	196.76 ± 1.28		9.41 ± 1.10										
Fast					3.00 ± 0.30		190.35 ± 1.71		2.650 ± 0.132 ^c		9.92 ± 0.95		200.27 ± 1.96
²³³ U	198.15 ± 0.12		6.84 ± 0.07										
Thermal					0.03 ± 0.01		191.34 ± 0.14		2.495 ± 0.125		8.98 ± 0.89		200.32 ± 0.90
Fast					0.50 ± 0.10		191.81 ± 0.17		2.515 ± 0.125		9.10 ± 0.89		200.91 ± 0.91
14 MeV					14.00 ± 0.20		205.31 ± 0.24		4.270 ± 0.214		19.75 ± 1.64		225.06 ± 1.66
²³⁴ U	197.88 ± 0.83		8.15 ± 1.10										
Fast					2.36 ± 0.10		192.09 ± 1.38		2.665 ± 0.133		10.01 ± 0.95		202.10 ± 1.68
²³⁵ U	202.69 ± 0.06		8.62 ± 0.09										
Thermal					0.03 ± 0.01		194.10 ± 0.11		2.422 ± 0.121		8.54 ± 0.85		202.64 ± 0.86
Fast					0.50 ± 0.10		194.57 ± 0.15		2.472 ± 0.124		8.84 ± 0.88		203.41 ± 0.89
14 MeV					14.00 ± 0.20		208.07 ± 0.23		4.377 ± 0.219		20.40 ± 1.68		228.47 ± 1.70
²³⁶ U	201.93 ± 0.23		9.87 ± 1.10										
Fast					2.37 ± 0.10		194.43 ± 1.13		2.781 ± 0.139		10.71 ± 1.00		205.14 ± 1.51
²³⁸ U	206.13 ± 0.26		11.04 ± 0.11										
Fast					3.10 ± 0.10		198.19 ± 0.30		2.790 ± 0.140		10.77 ± 1.01		208.96 ± 1.05
14 MeV					14.00 ± 0.20		209.09 ± 0.35		4.424 ± 0.221		20.68 ± 1.70		229.77 ± 1.74
²³⁷ Np	202.34 ± 0.86		8.36 ± 1.10										
Fast					2.37 ± 0.10		191.61 ± 1.40		3.046 ± 0.152		12.32 ± 1.12		203.93 ± 1.79
²³⁸ Pu	204.72 ± 0.28		7.28 ± 1.10										
Thermal					0.03 ± 0.01		197.47 ± 1.14		2.895 ± 0.145		11.41 ± 1.05		208.88 ± 1.55
²³⁹ Pu	207.20 ± 0.13		7.10 ± 0.07										
Thermal					0.03 ± 0.01		200.13 ± 0.15		2.880 ± 0.144		11.31 ± 1.05		211.44 ± 1.06
Fast					0.50 ± 0.10		200.60 ± 0.18		2.937 ± 0.147		11.66 ± 1.07		212.26 ± 1.09
14 MeV					14.00 ± 0.20		214.10 ± 0.25		4.899 ± 0.245		23.57 ± 1.91		237.67 ± 1.93
²⁴⁰ Pu	205.80 ± 0.24		8.64 ± 1.10										
Fast					2.39 ± 0.10		199.55 ± 1.13		2.937 ± 0.147		11.66 ± 1.07		211.21 ± 1.56
²⁴¹ Pu	210.97 ± 0.22		8.80 ± 0.09										
Thermal					0.03 ± 0.01		202.20 ± 0.24		2.868 ± 0.143		11.24 ± 1.04		213.44 ± 1.07
Fast					0.50 ± 0.10		202.67 ± 0.26		2.945 ± 0.147		11.71 ± 1.07		214.38 ± 1.10
²⁴² Pu	209.60 ± 1.40		10.34 ± 1.10										
Fast					2.32 ± 0.10		201.58 ± 1.78		3.309 ± 0.165		13.92 ± 1.23		215.50 ± 2.16
²⁴¹ Am	209.64 ± 0.28		7.55 ± 1.10										
Thermal					0.03 ± 0.01		202.12 ± 1.14		2.910 ± 0.146		11.50 ± 1.06		213.62 ± 1.56
^{242m} Am	212.31 ± 1.06 ^b		10.02 ± 0.60 ^b										
Thermal					0.03 ± 0.01		202.32 ± 1.22		3.090 ± 0.155		12.59 ± 1.14		214.91 ± 1.67
²⁴³ Am	209.98 ± 1.64		8.81 ± 1.10										
Fast					3.00 ± 0.50		204.17 ± 2.04		3.831 ± 0.192		17.08 ± 1.45		221.25 ± 2.50
²⁴³ Cm	212.44 ± 1.06 ^b		8.47 ± 0.51 ^b										
Thermal					0.03 ± 0.01		204.00 ± 1.18		3.430 ± 0.172		14.65 ± 1.28		218.65 ± 1.74
²⁴⁴ Cm	211.67 ± 0.54		8.50 ± 1.10										
Thermal					0.03 ± 0.01		203.20 ± 1.23		3.460 ± 0.173		14.83 ± 1.29		218.03 ± 1.78

a = R. Sher and C. Beck, private communication, b = ENDF/B-V, c = ENDF/B-IV

APPENDIX E

ACTINIDE DECAY POWER IN LWR SYSTEMS

Following the development and approval of the new ANS 5.1 Standard for decay power, a series of calculations were performed to investigate the temporal magnitude of actinide decay power. The standard, described in the text and in Appendix A, incorporated the results of experiments and summation calculations into useful pulse functions for $^{235}\text{U}/^{238}\text{U}$ fuels. However, the standard provides little information on actinide decay power, limiting discussion to ^{239}U and ^{239}Np . The graphical results of these calculations, presented in part in Ref. 15 of the text, are included here to demonstrate the importance of actinide decay power in general and individual nuclides in particular.

The fuel cases examined, described in Table E-I, consist of 4 LWR systems. As in previous calculations, the EPRI-CINDER code was used in calculating temporal fission histories, flux levels, and actinide decay power values using exposure-dependent, self-shielded actinide cross-sections calculated with EPRI-CELL. The nuclide fission histories for case 1A, for example, are shown in Fig. E-1. The EPRI-CINDER code was also used to provide fission-product decay power values for cooling times $t \geq 10^5$ s. Fission-product decay power values at cooling times $t \leq 4 \times 10^4$ s were obtained with DKPOWR using the nuclide fission history from EPRI-CINDER and the G_{max} absorption correction. The fission-product decay power for case 1A, using the nuclide fission history of Fig. E-1, is shown in Fig. E-2. In the cooling-time range 10^5 s $\leq t \leq 10^9$ s within which both solutions of fission-product decay power are valid, the absorption effect accurately included in the EPRI-CINDER calculation is seen to be considerably less than the G_{max} correction to the fission-product decay power calculated with DKPOWR, using the standard.

The actinide nuclide library of EPRI-CINDER includes all actinide nuclides from ^{208}Tl to ^{246}Cm important to a variety of actinide calculations. Those nuclides important to decay power in $^{235}\text{U}/^{238}\text{U}$ fuel, ranging from ^{234}U to ^{244}Cm , are shown in Fig. E-3. Because of the high density of ^{238}U , most of the higher-mass actinide production stems from ^{238}U radiative capture. The temporal fractional contribution of each actinide nuclide for case 1A

is shown in Fig. E-4, and the aggregate fission-product and actinide decay power values are compared in Fig. E-5. The fractional contribution of actinides to decay power in this case is shown in Fig. E-6.

Early calculations performed to estimate TMI-2 decay power assumed an 88-day constant-power history. Actinide-nuclides important to decay power following this brief power history are fewer in number, as shown in Fig. E-7. Actinide and fission-product contributions to total decay power, compared in Fig. E-8, decay more rapidly following the first day of cooling. The slight increase in actinide decay power at cooling times $t > 10^7$ s is due to the buildup of ^{241}Am via ^{241}Pu decay. The case 1 actinide fraction of total decay power following four irradiation histories are compared in Fig. E-9.

Actinide nuclides important to BWR fuel decay power are examined in Fig. E-10. In these calculations, self-shielded actinide cross sections were obtained with EPRI-CELL assuming 40% void in the coolant water. Complexities of BWR design, including void fraction variation with height from 0% to ~70%, inhibit the modeling of total core properties using core-averaged parameters.

The actinide fraction of total decay power for the three cases of $^{235}\text{U}/^{238}\text{U}$ fuel following 34 Gwd/t exposure are compared in Fig. E-11. With reference to Fig. E-9, the temporal actinide fraction of total decay power appears to be more strongly related to exposure than initial enrichment, suggesting a functional approximation to account for actinide decay power equivalent to G of the standard accounting for fission-product neutron absorption. The envelope of actinide fractions of all $^{235}\text{U}/^{238}\text{U}$ fuel cases is used to form an "actinide correction factor" and compared to the similar G_{max} of the standard in Fig. E-12. Here the importance of actinide decay power during early cooling times important to LOCA is clearly much more significant than the effect of neutron absorption in fission products.

The nuclides important to actinide decay power in $^{232}\text{Th}/^{233}\text{U}$ fuel range from ^{208}Tl and other ^{232}U decay products to ^{238}Pu , as shown in Fig. E-13. The temporal contributions of each of these nuclides to actinide decay power are shown in Fig. E-14 for the case 4 fuel. Fission-product decay power was calculated as before with DKPOWR for $t \leq 4 \times 10^4$ s using the ^{235}U pulse function to represent ^{233}U . This substitution is not specifically sanctioned by the standard and is used here simply to form an approximate basis for the comparison with actinide decay power shown in Fig. E-15. The increase in actinide decay

at cooling times $t > 10^7$ s is due to the transient buildup and decay of ^{232}U following shutdown. The temporal fractional contribution of actinide nuclides in this $^{232}\text{Th}/^{233}\text{U}$ system is shown in Fig. E-16.

It is shown in the figures below that, at any cooling time, very few nuclides are responsible for actinide decay power in $^{235}\text{U}/^{238}\text{U}$ fuel. This has been emphasized in the comparison with the number of significant fission-product decay power contributors in Fig. B-1 of Appendix B.

TABLE E-I

SUMMARY OF FUEL CASES STUDIED

1. PWR, 2.56% U235/U238, 273W/cc
 - A. 34 GWD/MT (1082 days)
 - B. 15 GWD/MT (477 days)
 - C. 2.765 GWD/MT (88 days)
 - D. 0.1 GWD/MT (3.18 days)
2. PWR, 3.1% U235/U238, 273W/cc
34 GWD/MT (1082 days)
3. BWR, 2.95% U235/U238, 158W/cc
40% Void
34 GWD/MT (1909 days)
4. PWR, 2.95% U233/TH232, 328W/cc
C.E. System 80
34 GWD/MT (835 days)

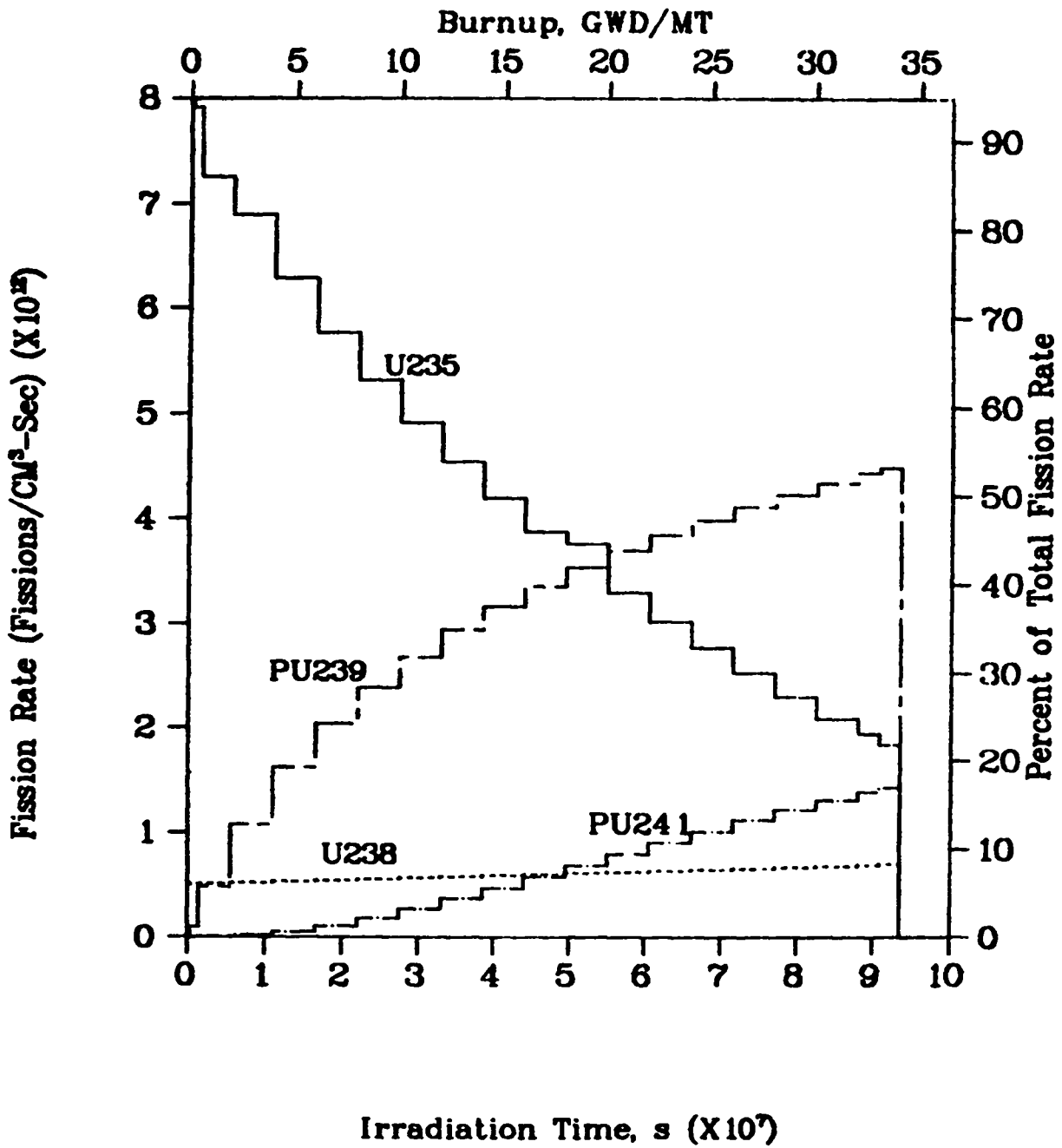

Fig. E-1.
 Nuclide fission history, case 1A,
 PWR, 2.56% U235/U238 fuel, 34 GWD/MT, 1082 days.

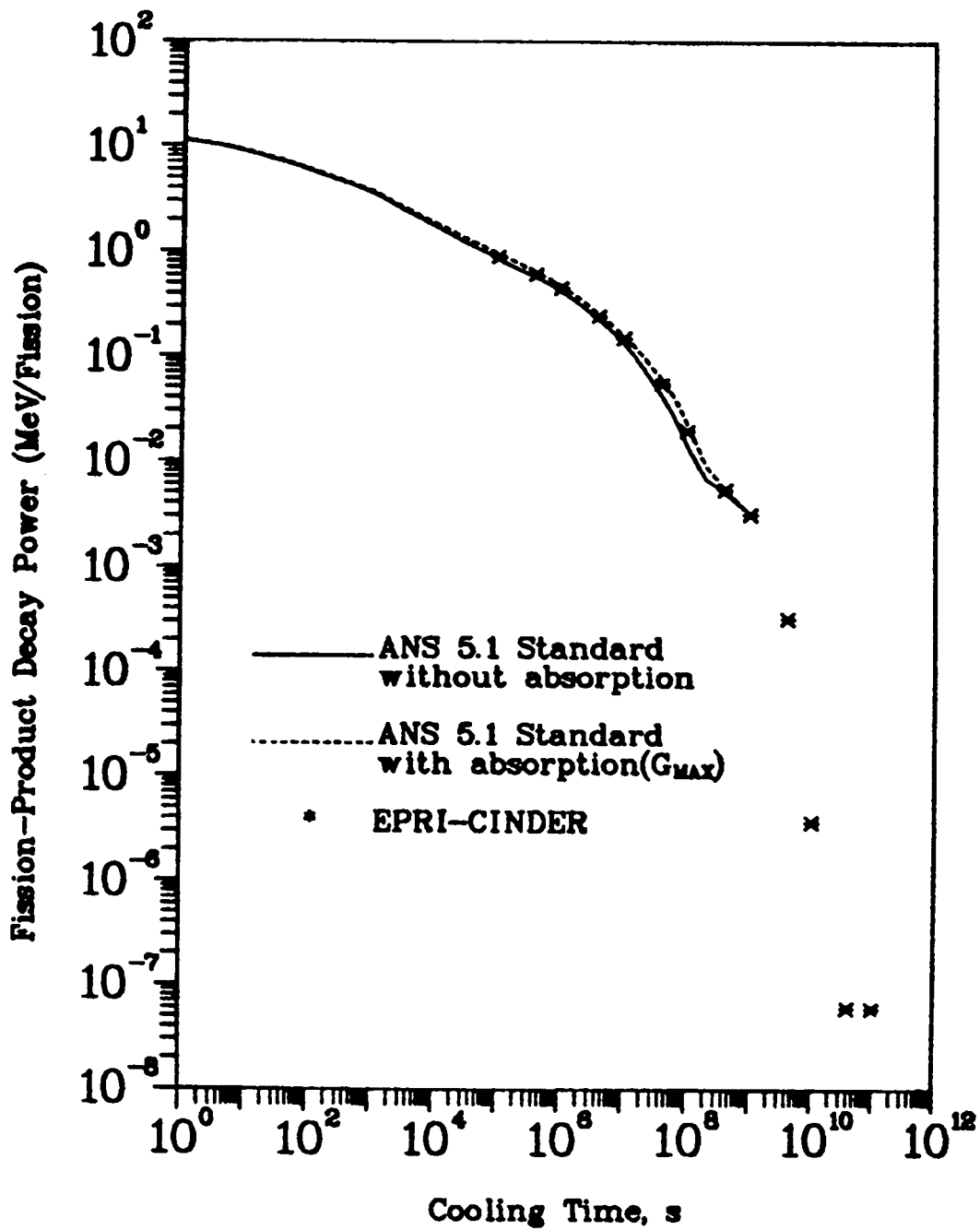

Fig. E-2.
 Fission-product decay power, case 1A,
 PWR, 2.56% U235/U238 fuel, 34 GWD/MT, 1082 days.

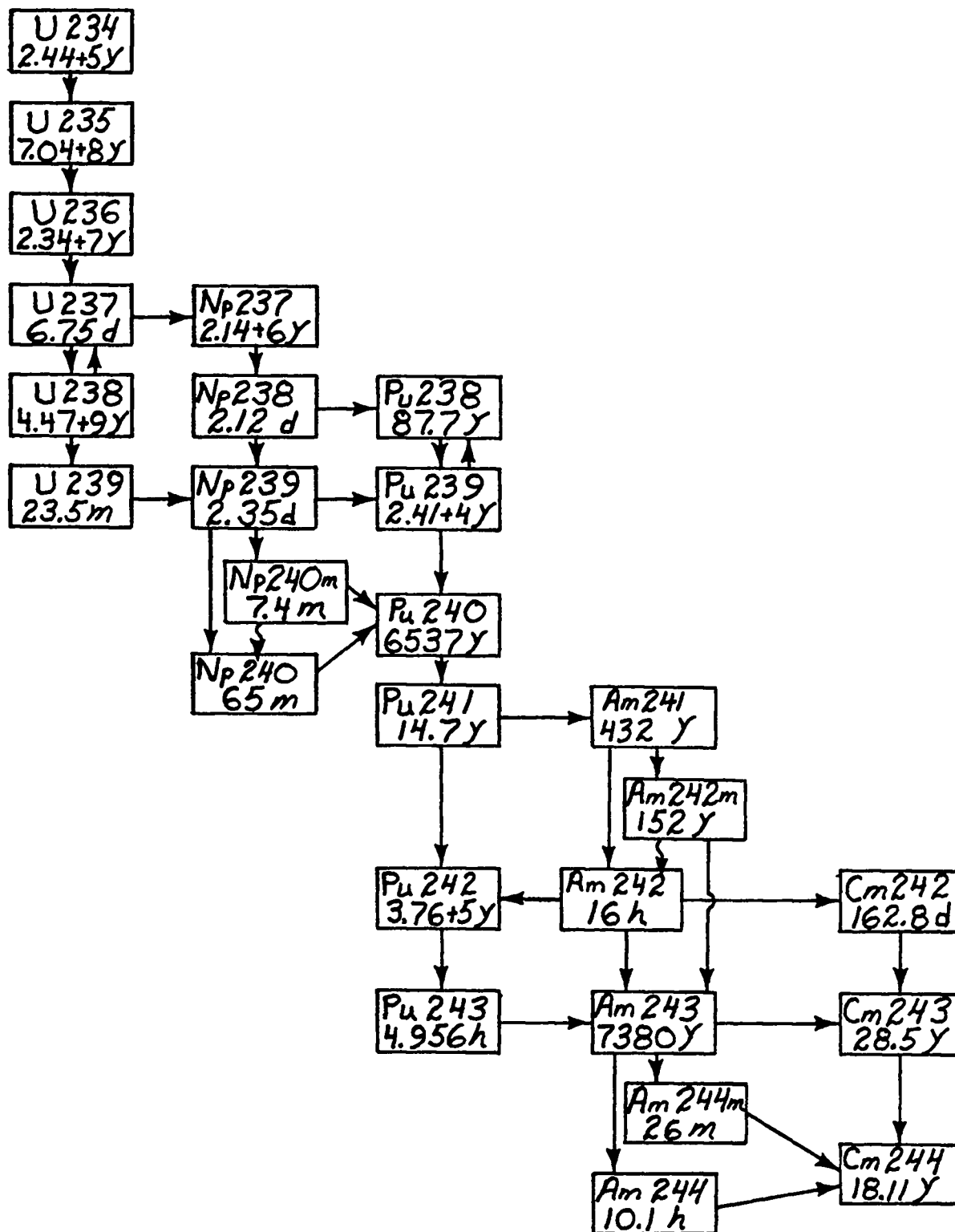

Fig. E-3.
Actinide nuclides important to decay power
in U235/U238-fueled light water reactors.

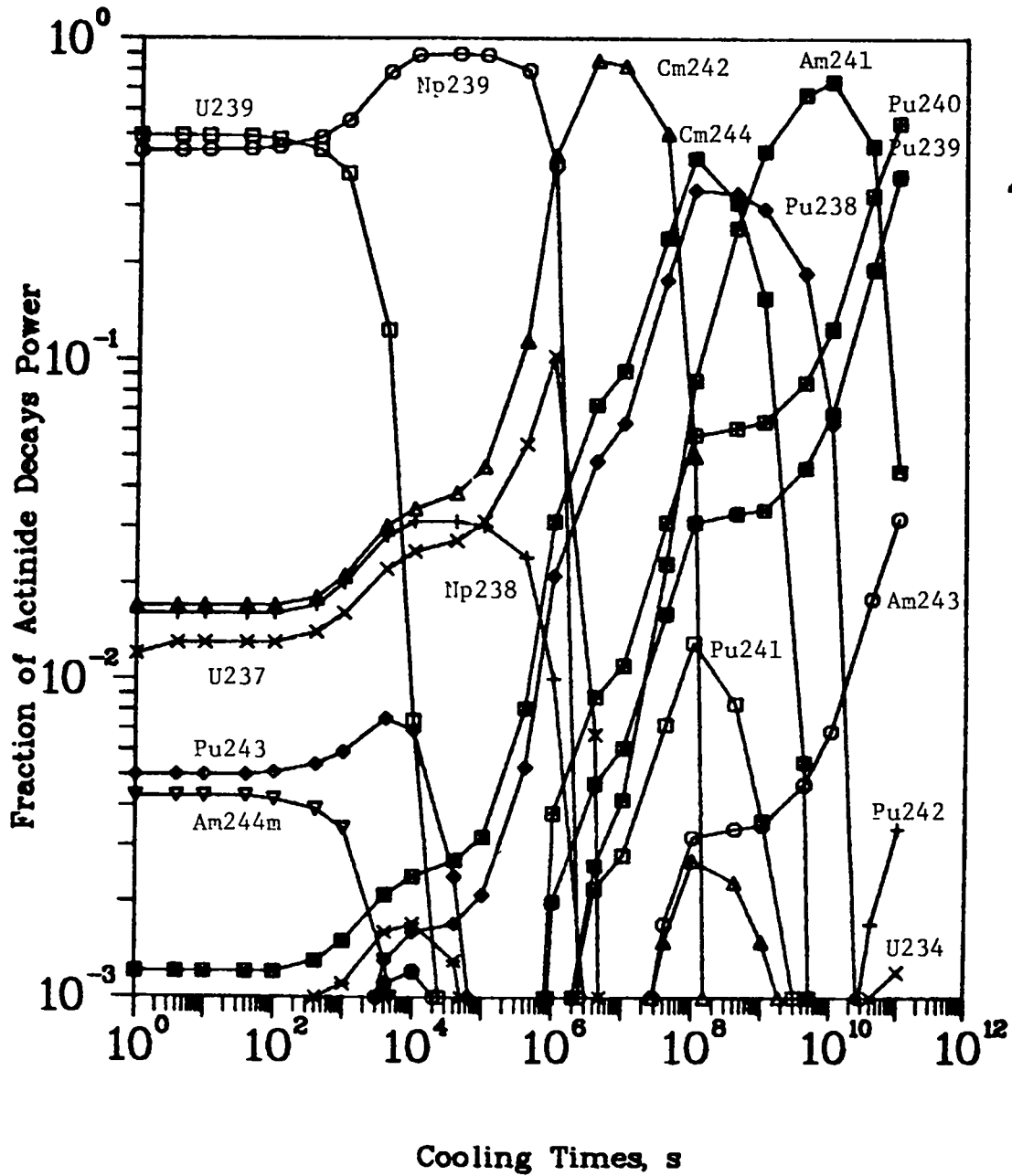

Fig. E-4.
 Nuclide contributors to actinide decay power, case 1A,
 PWR, 2.56% U235/U238 fuel, 34 GWD/MT, 1082 days.

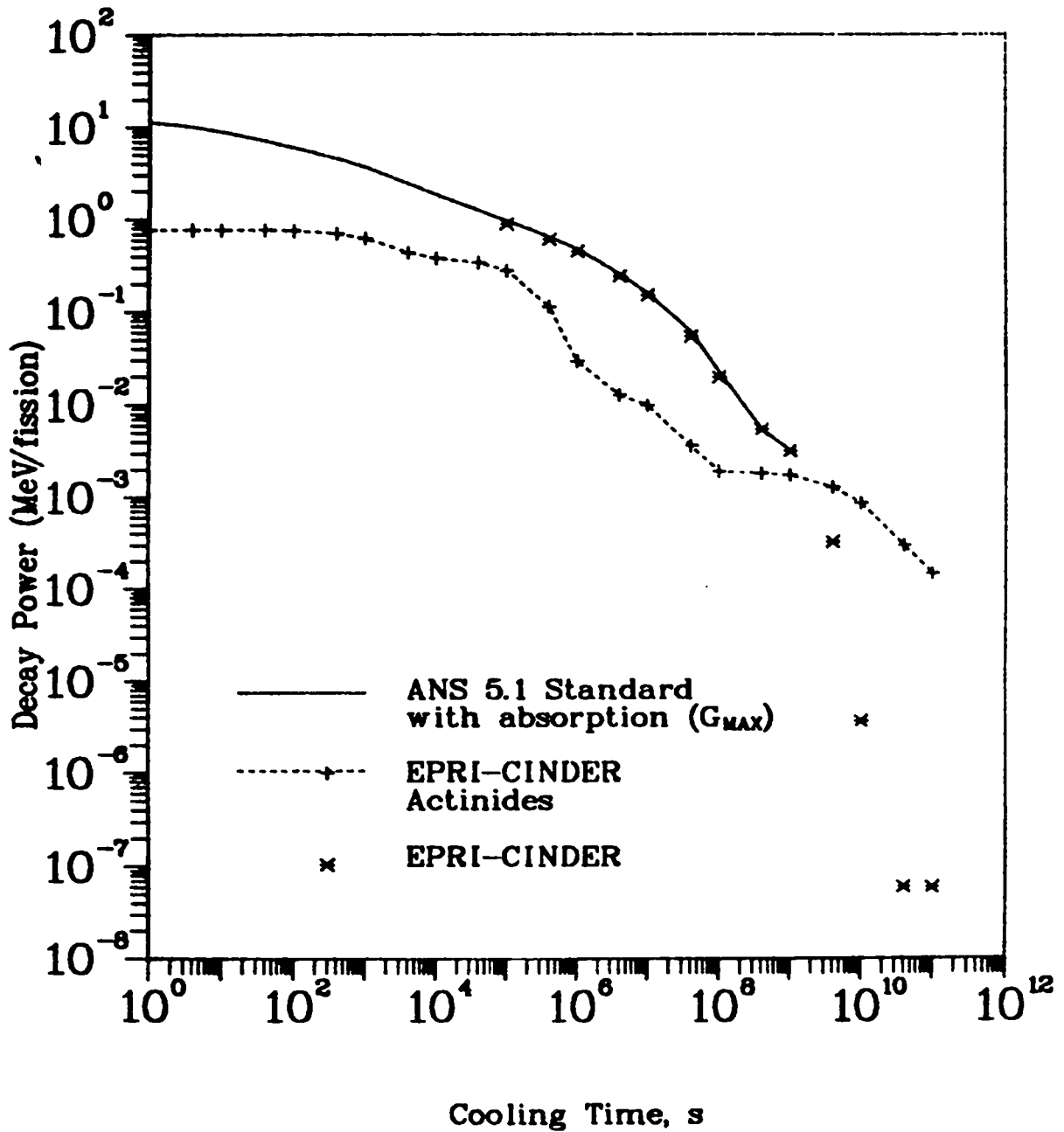

Fig. E-5.
 Fission-product and actinide decay power, case 1A,
 PWR, 2.56% U235/U238 fuel, 34 GWD/MT, 1082 days.

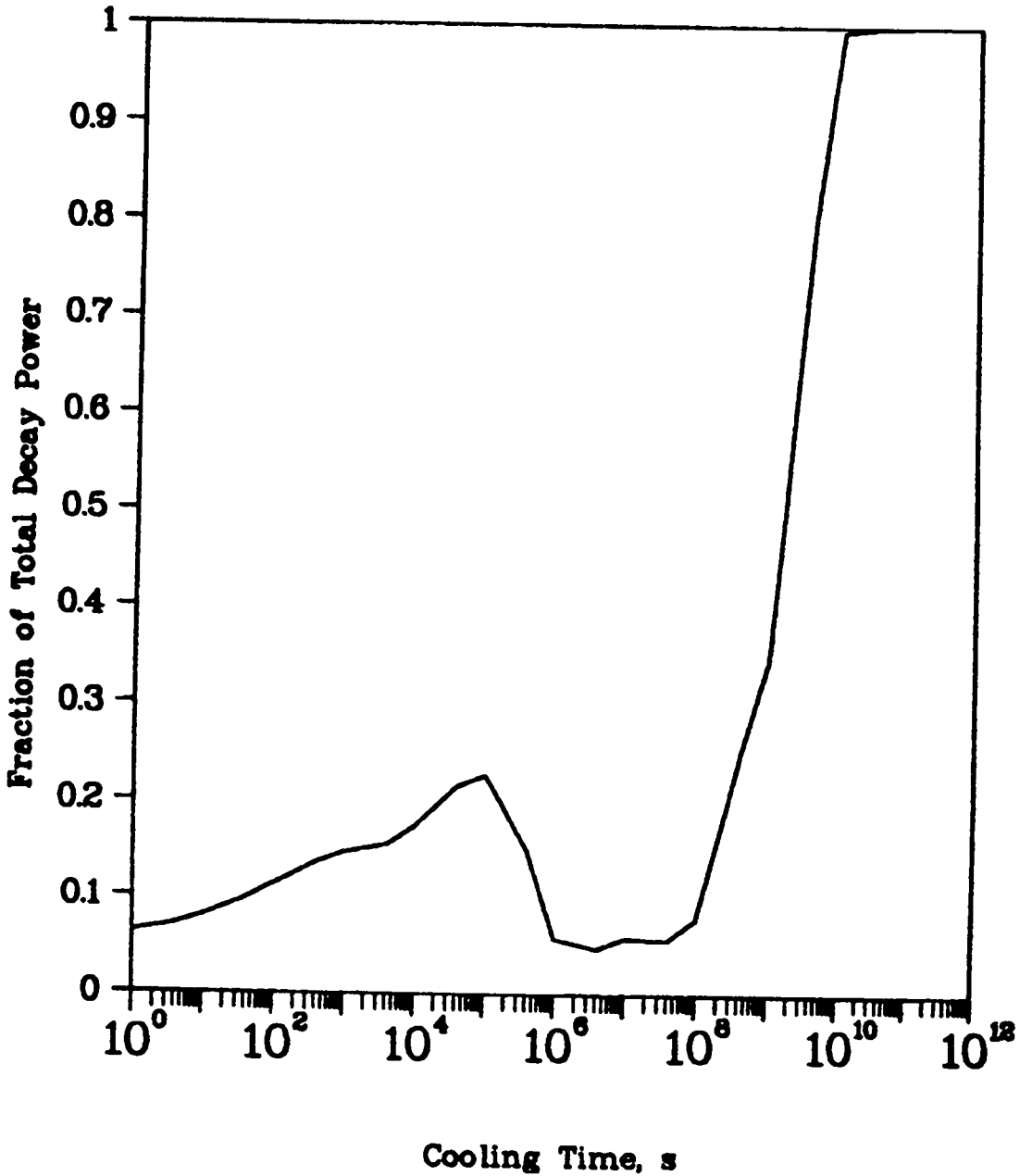

Fig. E-6.
 Actinide fraction of total decay power, case 1A,
 PWR, 2.56% U235/U238 fuel, 34 GWD/MT, 1082 days.

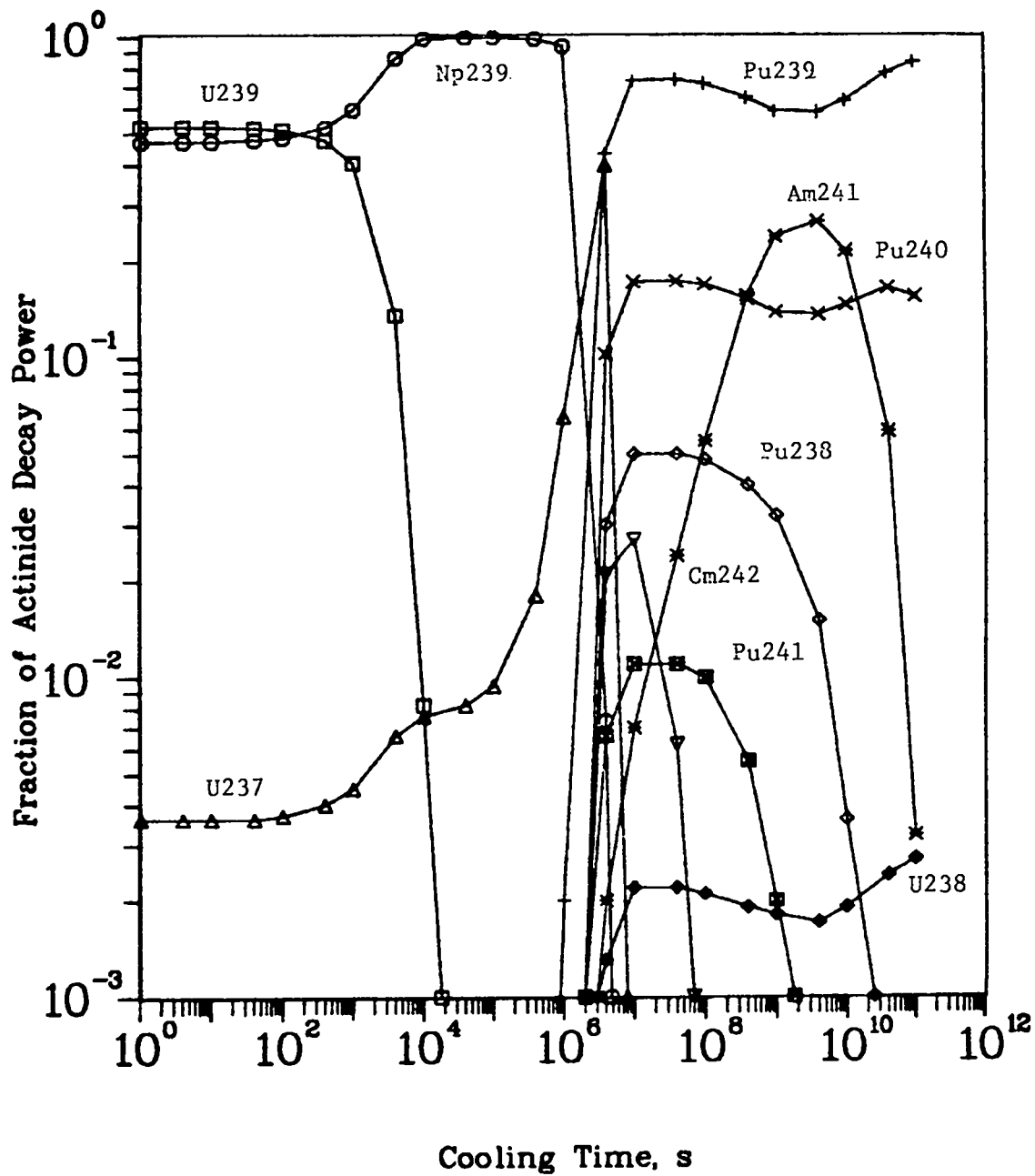

Fig. E-7.
 Nuclide contributors to actinide decay power, case 1C,
 PWR, 2.56% U235/U238 fuel, 2.765 GWD/MT, 88 days.

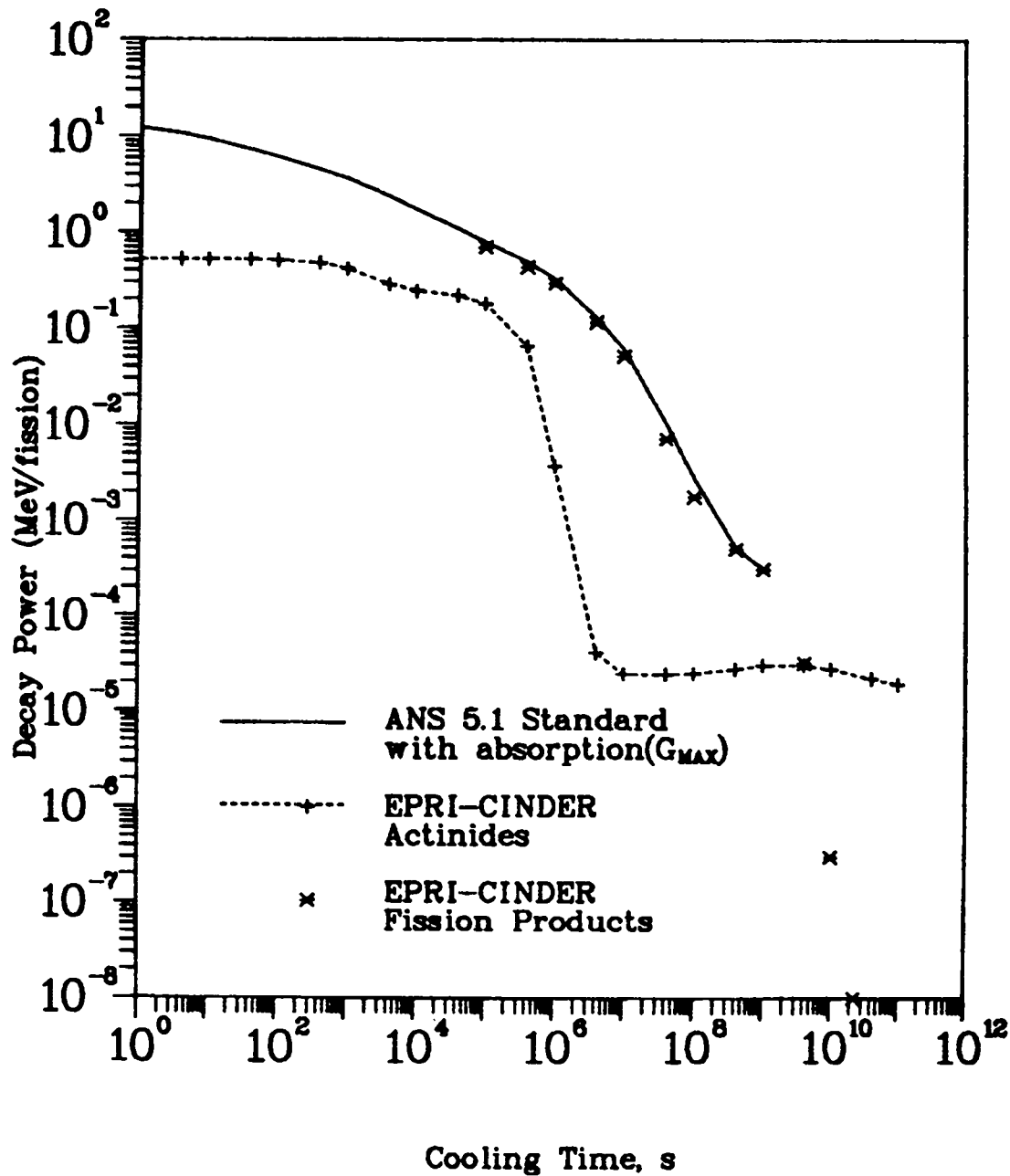

Fig. E-8.

Fission-product and actinide decay power, case 1C,
 PWR, 2.56% U235/U238 fuel, 2.765 GWD/MT, 88 days.

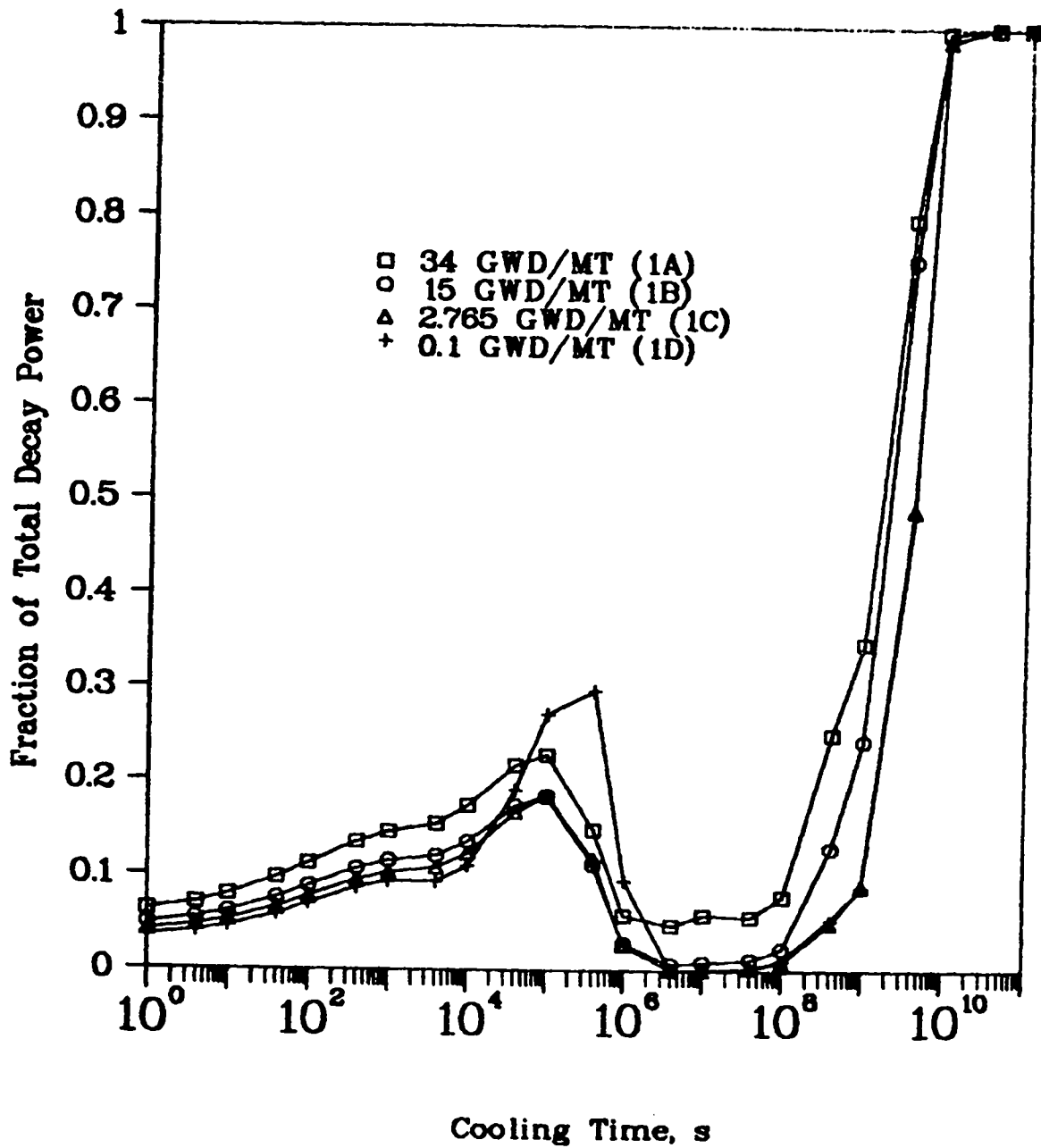

Fig. E-9.
 Actinide fraction of total decay power,
 cases 1A, 1B, 1C, and 1D,
 PWR, 2.56% U235/U238 fuel, 0.1-34 GWD/MT.

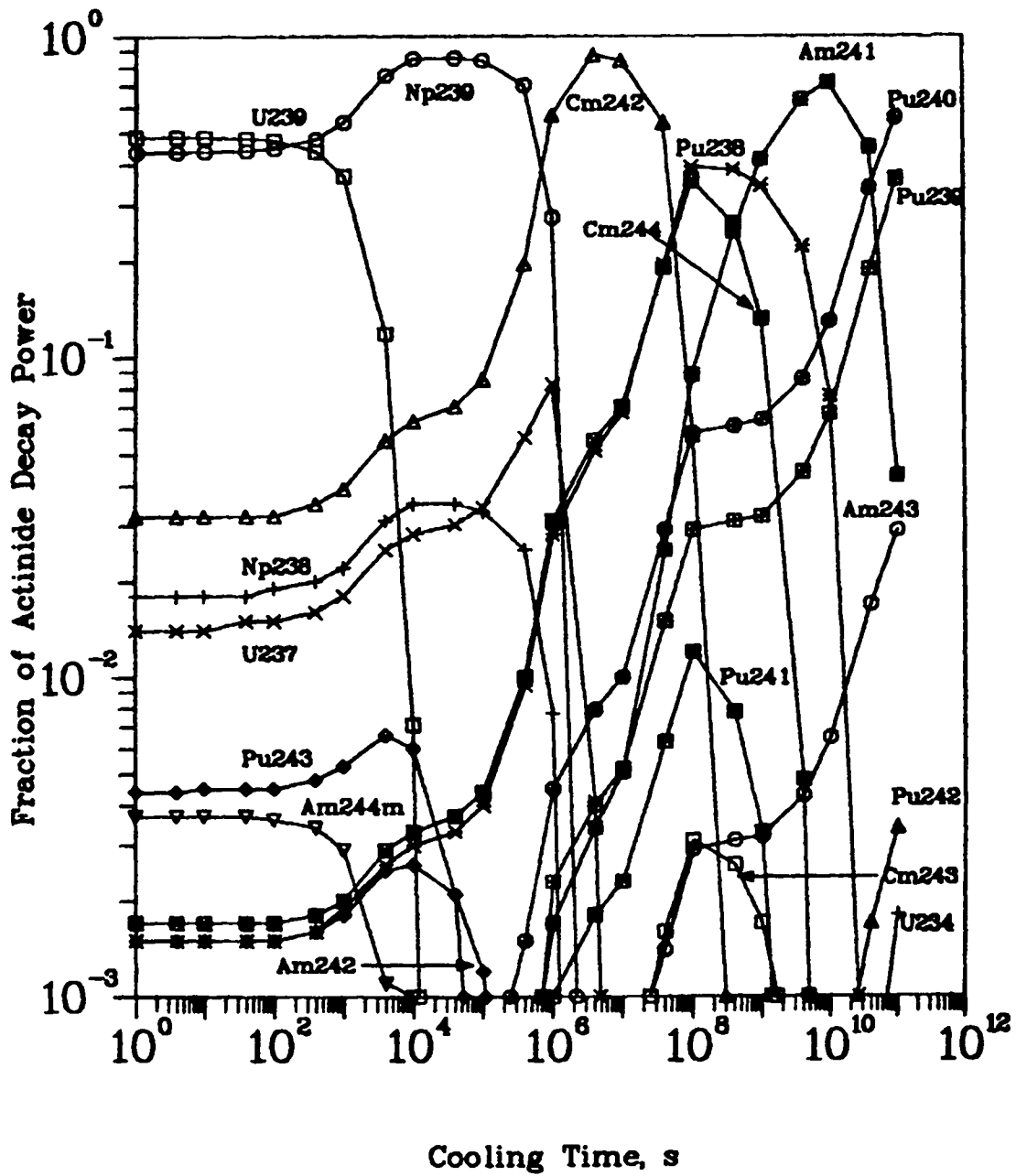

Fig. E-10.
 Nuclide contributors to actinide decay power, case 3
 BWR, 2.95% U235/U238 fuel, 34 GWD/MT, 1909 days.

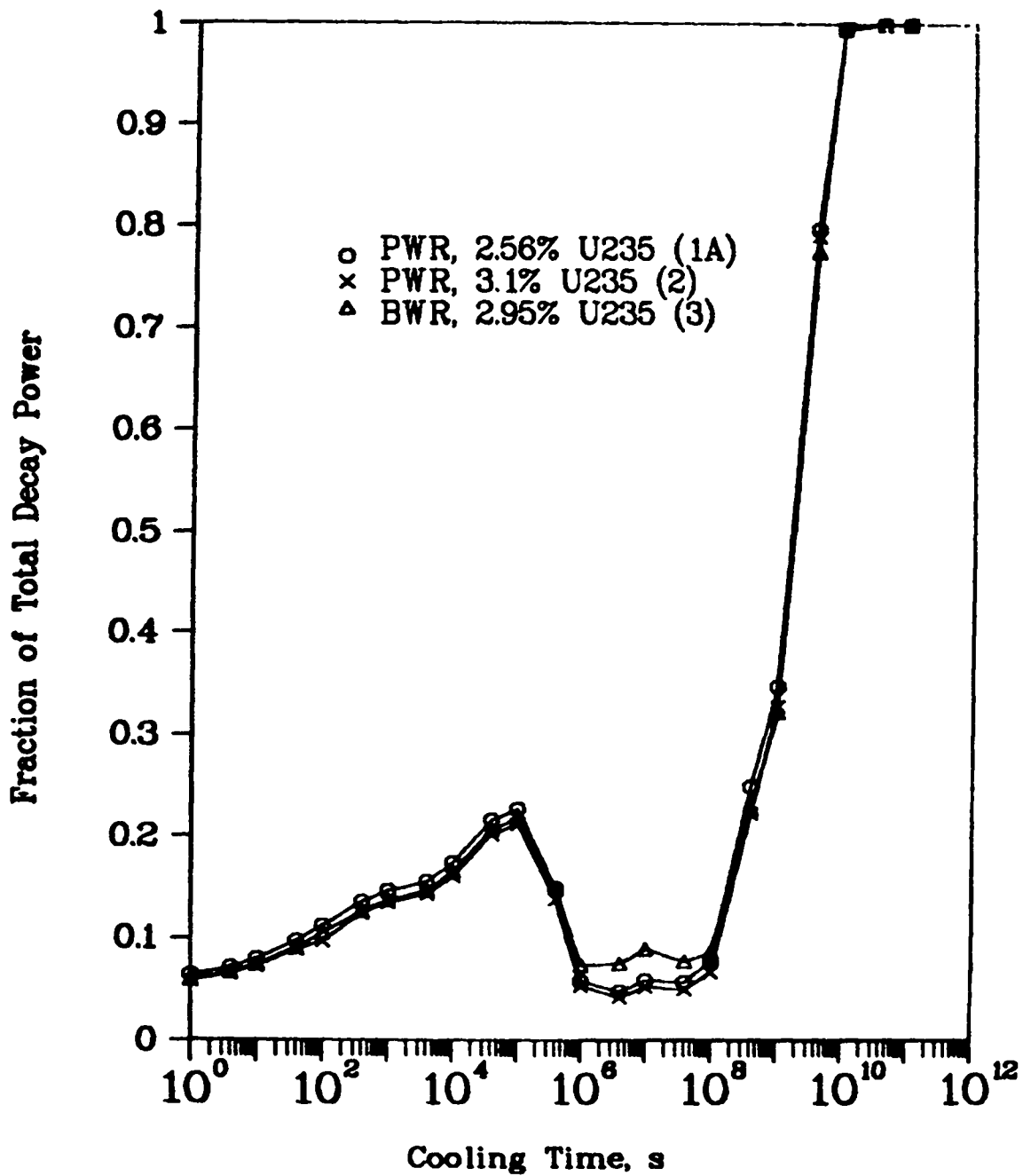

Fig. E-11.
 Actinide fraction of total decay power, cases 1A, 2 and 3,
 low-enrichment U235/U238-fueled LWRs, 34 GWD/MT.

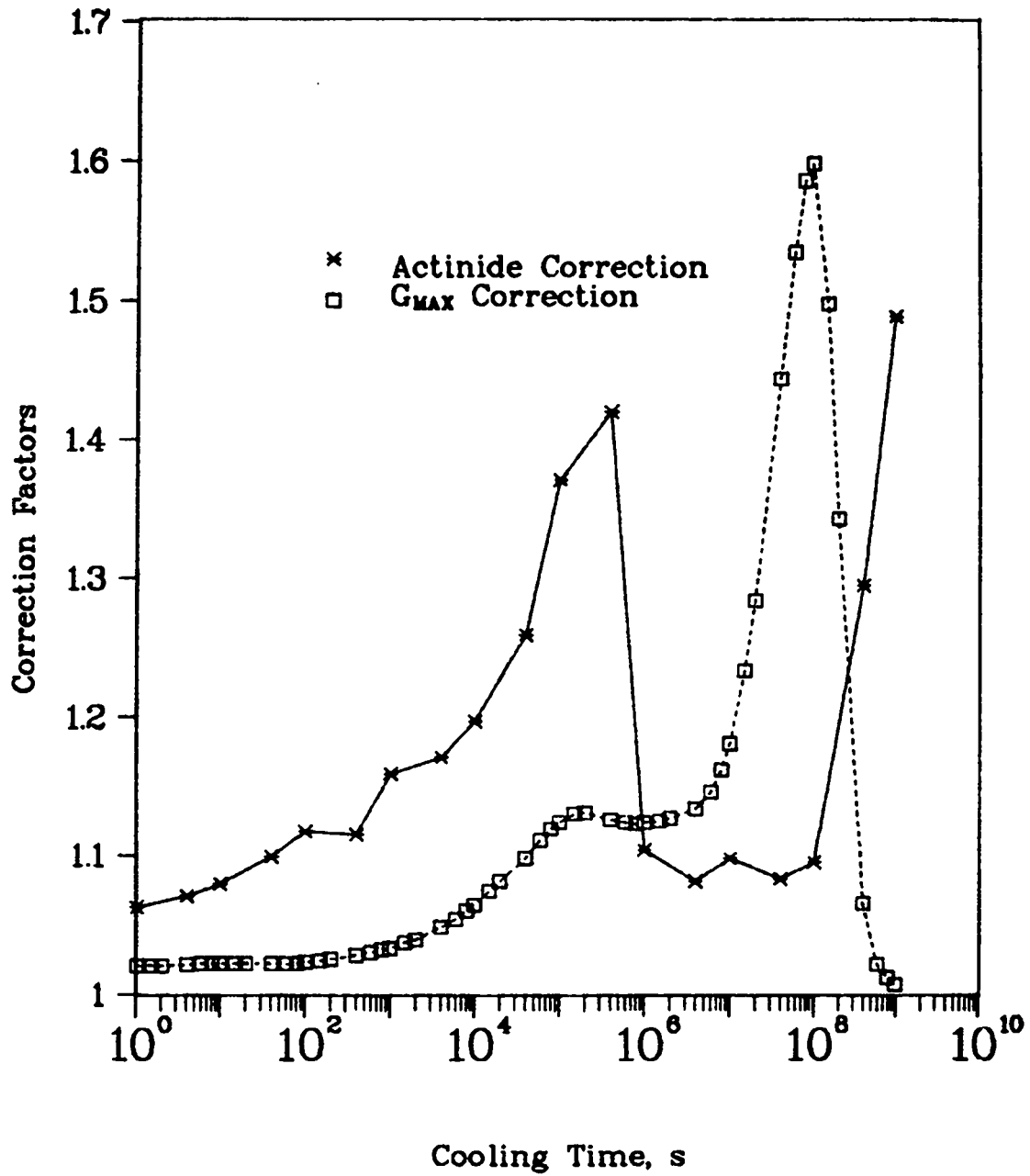

Fig. E-12.
 Conceptual upper-bound actinide decay power correction factor for U235/U238-fueled LWRs.

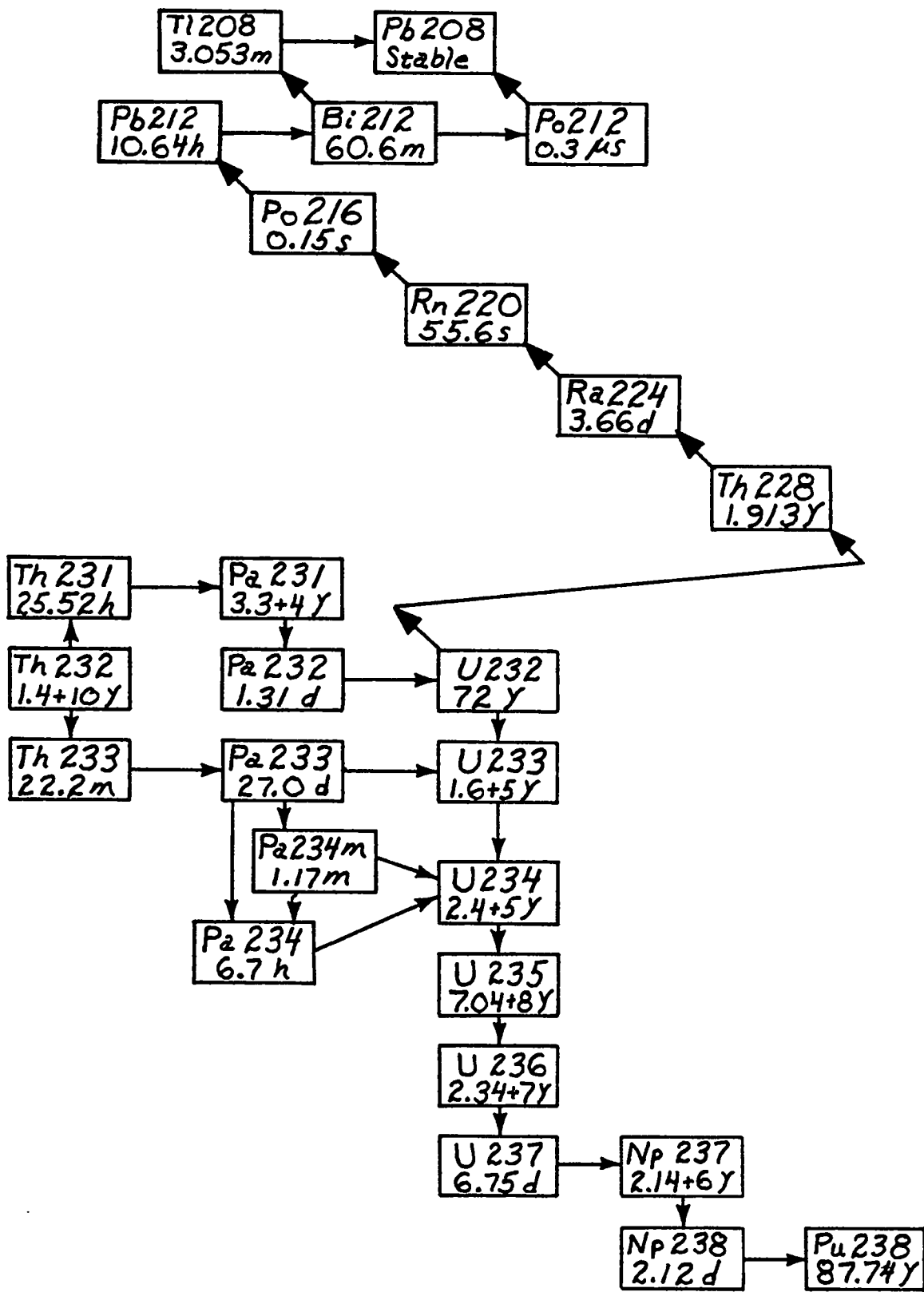

Fig. E-13.
 Actinide nuclides important to decay power
 in U²³³/Th²³²-fueled light water reactors.

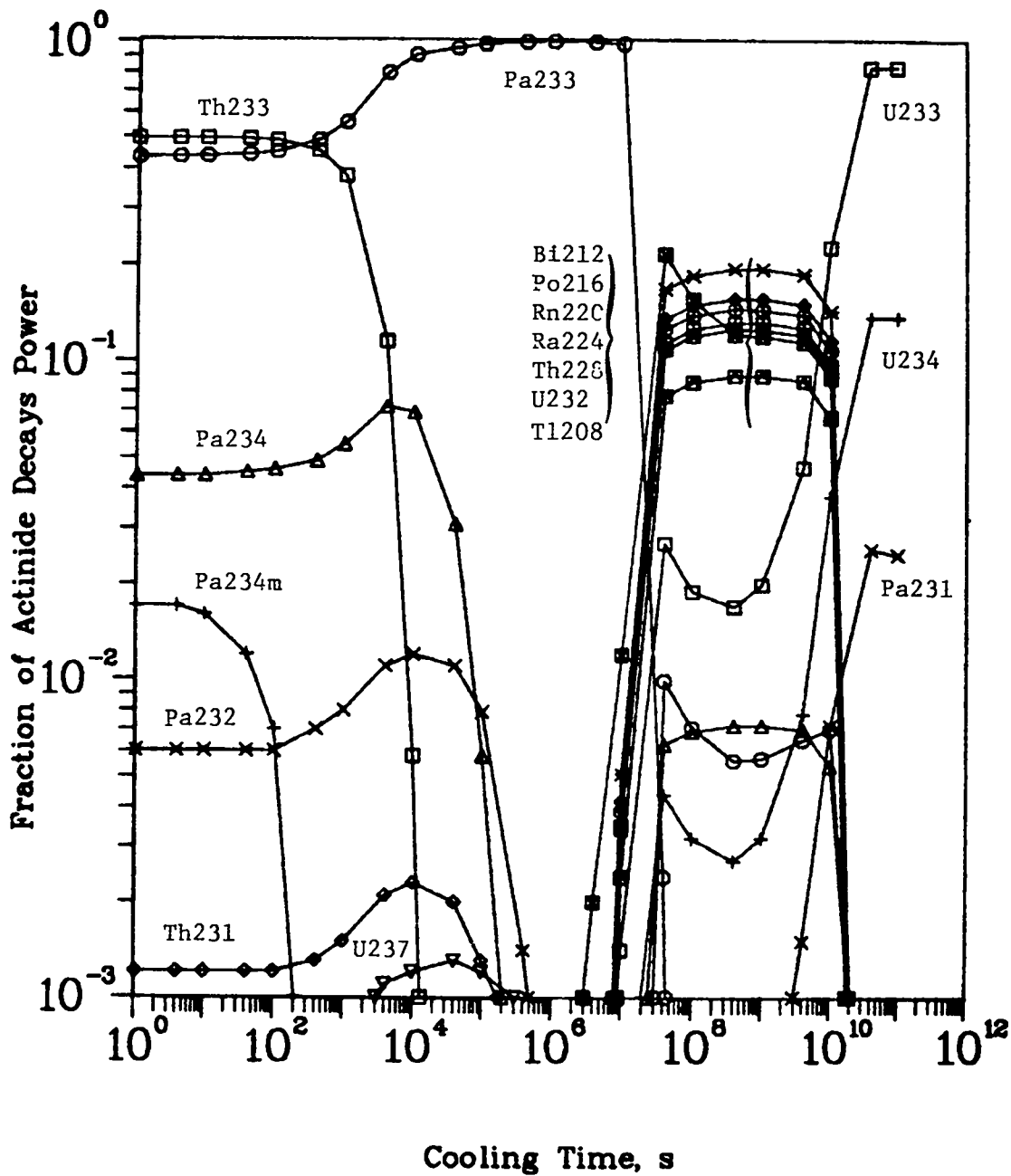

Fig. E-14.
 Nuclide contributors to actinide decay power, case 4,
 PWR, 2.95% U233/Th232 fuel, 34 GWD/MT, 835 days.

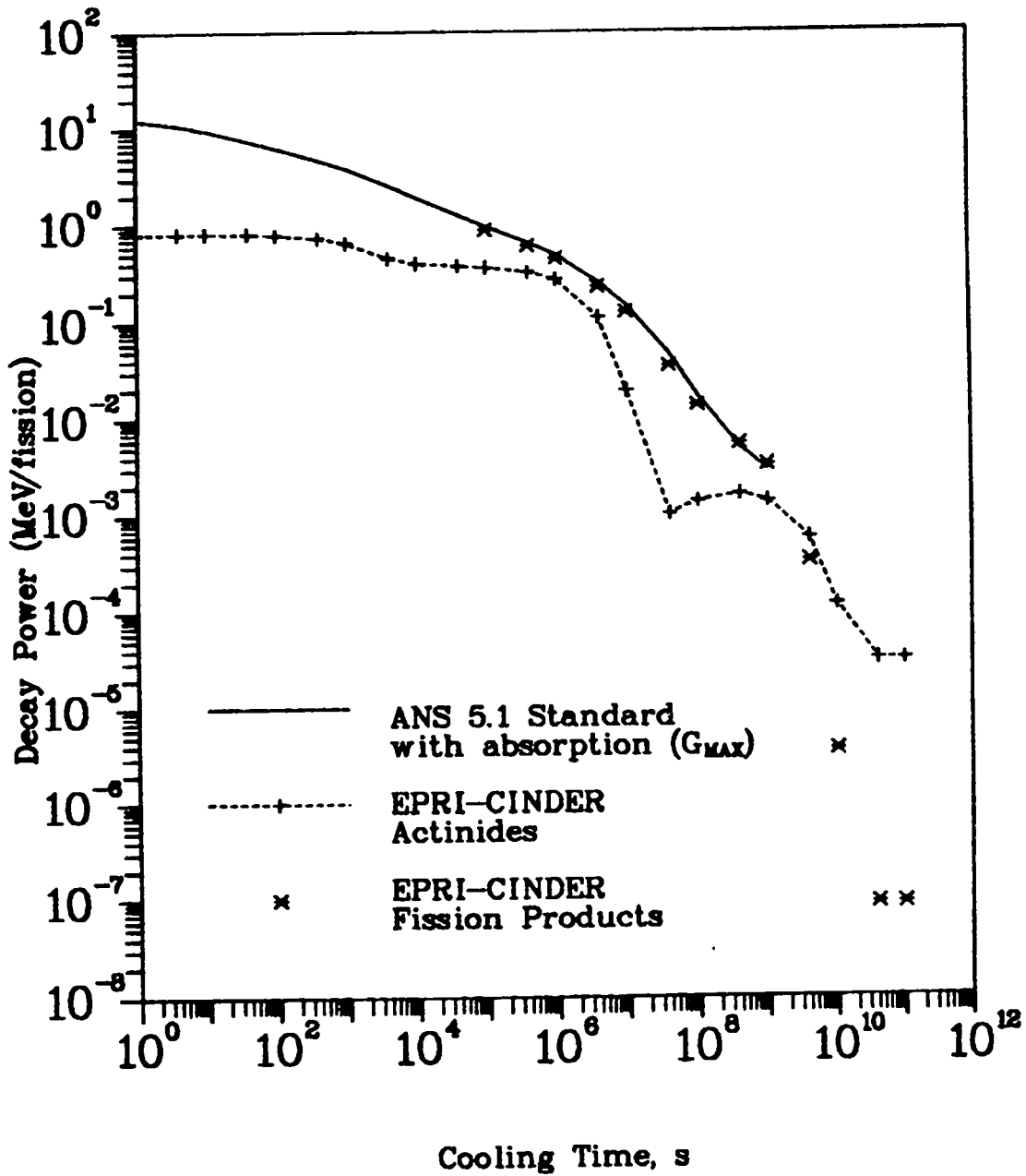

Fig. E-15.
 Fission-product and actinide decay power, case 4,
 PWR, 2.95% U233/Th232 fuel, 34 GWD/MT, 835 days.

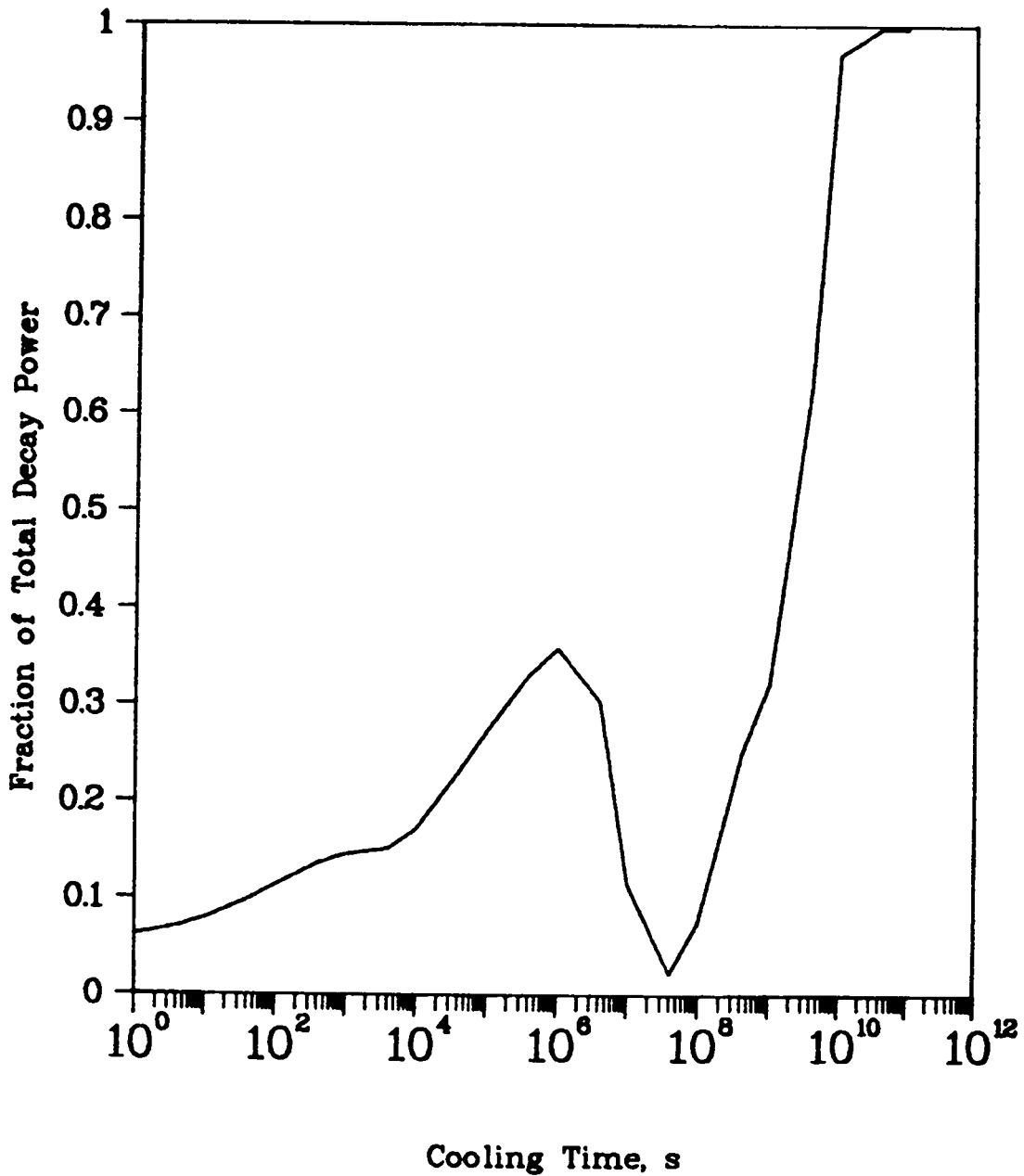

Fig. E-16.
 Actinide fraction of total decay power, case 4,
 PWR, 2.95% U233/Th232 fuel, 34 GWD/MT, 835 days.

LACL
CLASSIFIED
REPORT LIBRARY

NOV -2 1979

RECEIVED